



photoLab[®] S6

PHOTOMETER



a xylem brand



LAB Online Exhibition





For the most recent version of the manual, please visit www.WTW.com.

Scope of delivery

- Photometer
- Power pack
- Product documentation

Copyright

© Weilheim 2018, WTW GmbH
Reproduction in whole - or even in part - is prohibited without the
express written permission of WTW GmbH, Weilheim.
Printed in Germany.

1. Overview	5
1.1 Description of the operating elements	5
1.2 Identifying the connectors	5
1.3 Short manual	6
1.3.1 Measuring the concentration	6
1.4 Selecting and calling up the menu items	7
2. Safety	8
2.1 Authorized use	8
2.2 General instructions	8
2.2.1 Labeling of notes	8
2.2.2 Dangers of disregarding the safety instructions	8
2.2.3 Qualification of the personnel	8
2.2.4 Technical state of the meter	8
3. Commissioning	10
3.1 Preparing the photometer	10
3.2 Switching on the photometer	10
4. Measuring the Concentration	11
4.1 Display of concentration and absorption	11
4.2 Measuring using cell tests	12
4.3 Measuring using tests without barcode (manual method selection)	13
5. Measuring the Absorbance/Transmission	14
5.1 Switching to the Absorbance/ Transmission measuring mode	14
5.2 Measuring the absorbance or transmission	14
5.3 Measuring using cell tests	15
5.4 Measuring using tests without barcode	15
6. Documentation	16
6.1 Resetting the number of the measured value	17
6.2 Download memory	17
6.3 Download of the methods list	19
7. Method Parameters	20
7.1 Citation form	21
7.1.1 Changing the citation form	21
7.1.2 Performing a difference measurement	22
7.2 Selecting the unit	24
8. Analytical Quality Assurance (AQA)	25
8.1 Activating AQA	25
8.1.1 Activating AQA via the menu guide	25
8.1.2 Changing AQA intervals	27
8.1.3 Locking the system	29
8.1.4 Changing the password	30
8.1.5 Performing an AQA reset	30

Contents

8.2	Photometer monitoring (AQA1)	31
8.2.1	Entering PhotoCheck standards	31
8.2.2	Download of PhotoCheck standards	33
8.2.3	Erasing PhotoCheck standards	33
8.2.4	Performing Photometer monitoring	34
8.3	Total system monitoring with standard solutions (AQA2)	36
8.3.1	Entering standards	36
8.3.2	Output of standards	38
8.3.3	Erasing standards	39
8.3.4	Monitoring of the total system using standard solutions	39
9.	Correction functions	41
9.1	Blank value	41
9.1.1	Activating the blank value measurement	42
9.1.2	Measuring the blank value	43
9.1.3	Erasing blank values	43
9.1.4	Recalling blank values	44
9.2	Turbidity correction	45
10.	Zero adjustment	46
11.	Meter Setup	47
11.1	Selecting the language	47
11.2	Setting the date/time	48
11.3	Reset	48
11.4	System info	49
12.	Updating method data	50
13.	RS 232 C interface	52
13.1	Principle course of the remote control	52
13.2	Command list	52
13.3	Output format of measured values	53
13.4	Data transmission	53
13.5	Pin assignment	53
14.	Maintenance, cleaning, disposal	54
14.1	Maintenance - Changing the lamp	54
14.2	Cleaning - Actions to take if a cell is broken	54
14.3	Disposal	55
15.	Technical Data	56
16.	What to do if...	58

1. Overview

1.1 Description of the operating elements

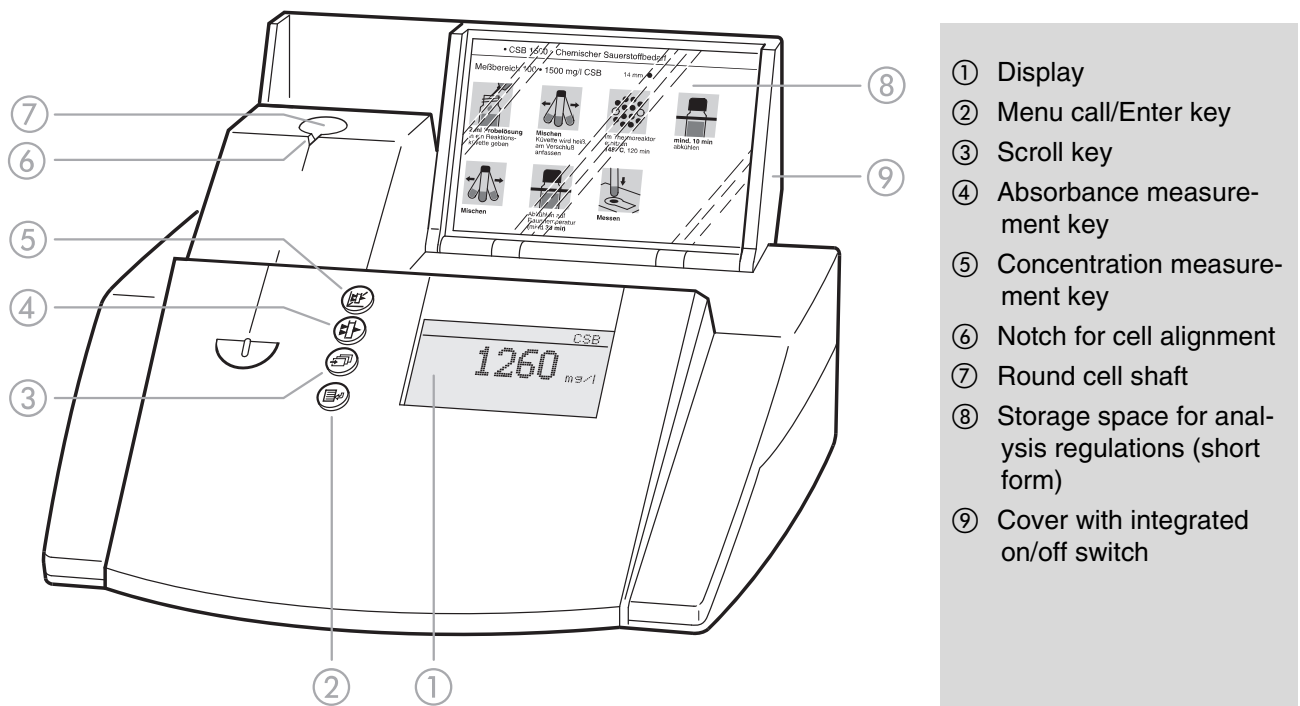

1.2 Identifying the connectors

- ① Power pack
- ② Connection for power pack
- ③ RS 232 interface

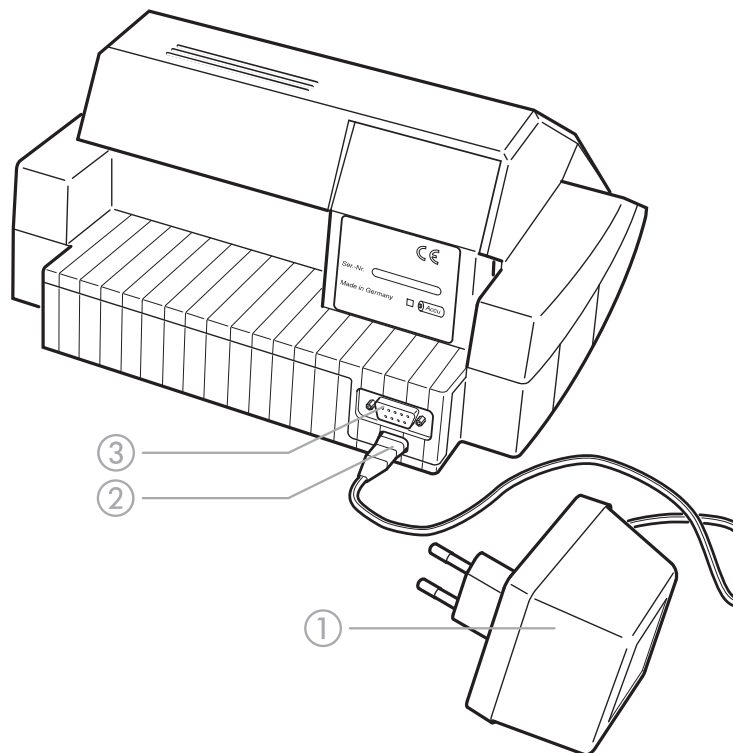

1. Overview

1.3 Short manual

The short manual lists all of the steps necessary to determine the concentration of a sample and to activate AQA2 at a glance.

1.3.1 Measuring the concentration

– To switch on the photometer, open the cover.

The photometer performs a check (*Self-Check*) of the entire system and then switches automatically to the *concentration measuring mode*.

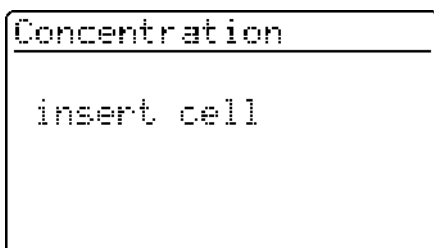

Measuring mode, *concentration*

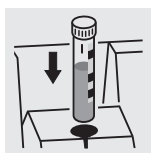

– Insert the round cell with barcode in the round cell shaft until it clicks into place.

Align the line mark to the notch of the photometer. The message *measuring... appears*.

i If the *select method* menu is displayed, align the line mark of the round cell to the notch of the photometer.

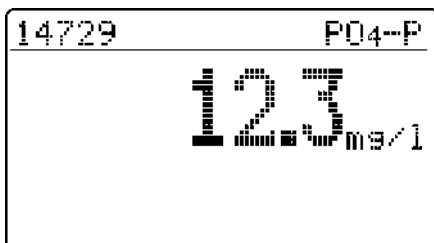

The measured value appears on the display. Measured values outside the specified measuring range are output in small numerals.

Repeat the measurement:

– Press .

1. Overview

1.4 Selecting and calling up the menu items

- To switch on the photometer, open the cover.
- Press .

The following display appears:

```
Setup
└documentation
  method Parameter
  Meter Setup
```

The following display appears:

```
Setup
  documentation
  method Parameter
  └Meter Setup
```

```
meter setup
  return
  └AQA functions
    correction funct.
    adjust zero
    set date/time
```

Example:

The *documentation* menu item is preselected in the *setup* menu (▶).



Select a menu item, e. g. *meter setup*:

- Press .



The *meter setup* menu item is preselected (▶).

- Call up the *meter setup* submenu by pressing .



The required menu item is

- selected using .
- called up using .

Selection lists:

- Changes to the settings are accepted after confirmation by pressing .
- Current settings are marked by "◆".
- Change to other configuration levels by
 - Selecting the menu item, *return*
 - Pressing .
- Scroll with .

Character input:

- by using ,
- the character to be input is shown in reverse video.
- Confirm each input with .

2. Safety

This operating manual contains basic instructions to be followed in the commissioning, operation and maintenance of the meter. Consequently, all responsible personnel must read this operating manual before

working with the meter. The operating manual must always be available in the vicinity of the meter.

2.1 Authorized use

The photometer is authorized exclusively for analyzing substances in water and aqueous solutions using round cells or rectangular cells (special optical glass). Observe the technical specifications of the

cells according to chapter 15 TECHNICAL DATA. Any other use is considered **unauthorized**.

2.2 General instructions

The photometer is constructed and tested according to the EN 61010-1 safety regulations for electronic measuring instruments. It left the factory in a safe and secure technical condition.

The smooth functioning and operational safety of the photometer can only be guaranteed under the climatic conditions specified in chapter 15 TECHNICAL DATA of this operating manual.

Opening the photometer or adjustment, maintenance and repair work must only be performed by personnel authorized by the manufacturer.

The only exceptions to this are the activities described in chapter 14 MAINTENANCE, CLEANING, DISPOSAL. Non-

compliance results in the loss of warranty claims. Follow the points listed below when operating the photometer:

- Follow local safety and accident prevention regulations.
- Observe the enclosed instructions concerning reagents and accessories.
- Observe the regulations when dealing with dangerous substances.
- Follow the operating instructions at the workplace.
- Use only original spare parts.

2.2.1 Labeling of notes



indicates notes that you must read – for your own safety, the safety of others and to protect your meter from being damaged.



indicates notes that draw your attention to special features.

2.2.2 Dangers of disregarding the safety instructions

Disregarding the safety instructions can adversely affect the safety of both the user and the environment as well as the equipment.

Non-compliance with the safety instructions will result in the loss of any warranty claims.

2.2.3 Qualification of the personnel

The personnel responsible for the commissioning, operation and maintenance must have the necessary qualifications for this work. If the personnel do not have the required skills they have to be instructed.

Furthermore, it must be ensured that the personnel read and completely understand the present operating manual.

2.2.4 Technical state of the meter

2. Safety

It is the responsibility of the operator to continuously observe the overall technical condition (externally recognizable deficits and damage as well as alterations to the operational behavior) of the meter. If safe operation is no longer possible, the equipment must be taken out of service and secured against inadvertent operation.

Safe operation is no longer possible if

- the equipment has been damaged in transport
- the equipment has been stored under adverse conditions for a lengthy period of time
- the equipment is visibly damaged
- the equipment no longer operates as prescribed.

If you are in any doubt, please contact the supplier of the photometer.

3. Commissioning

The photometer operates at an environmental temperature of +5 °C to +40 °C. During transport from cold to warm surroundings, condensation can form resulting in the malfunction of the meter.

Before putting the photometer into service, wait until it has adapted to the new environmental conditions (see also chapter 15 TECHNICAL DATA).

3.1 Preparing the photometer

- Place the photometer on a hard, flat surface and protect it against intensive light and heat.

Line operation

- Plug the original power pack into the socket on the photometer
- Plug the power pack into the line socket
- Switch on the photometer (open the cover).

Battery operation

- Charge the battery for approx. 5 hours before the initial commissioning. To do this:
 - Plug the original power pack into the socket on the photometer
 - Plug the power pack into the line socket and then the battery will be charged.

During battery operation or when the meter is at a standstill for longer periods of time, the battery runs down. This can result in your photometer no longer being ready for operation.

When the following symbol is displayed, charge the

battery: 

3.2 Switching on the photometer

- To switch on the photometer, open the cover. The photometer performs a check (*Self-Check*) of the entire system and then switches automatically to the *concentration* measuring mode.

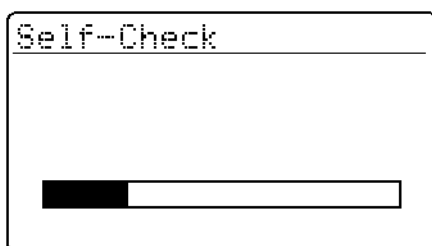

Self-check of the photometer

After approx.
5 s:

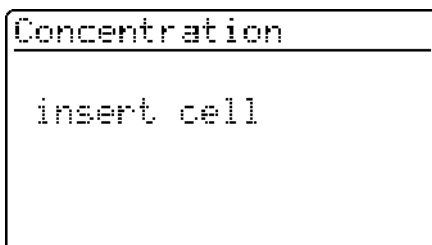

Automatic change to the measuring mode,
concentration

4. Measuring the Concentration

- Call up the *concentration* measuring mode by actuating .

```
Concentration
-----
insert cell
```

Measuring mode, *concentration*

4.1 Display of concentration and absorption

- Press  to call up the *setup* menu
- Call up the *meter setup* submenu.

```
Meter Setup
-----
return
AQA Functions
Correction Funct.
adjust zero
▶conc. / abs.
```

- In the *meter setup* menu, call up the *conc. / ext.* submenu.

```
conc. / abs.
-----
conc.
▶conc. + abs.
return
```

Selection of the measuring mode:

- *conc.*
- *conc. + abs.*

Example

```
14729          PO4--P
-----
          0.998 E
          12.3 mg/l
```

4. Measuring the Concentration

4.2 Measuring using cell tests

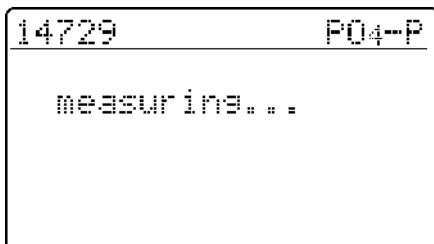
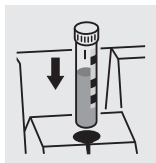

- Insert the round cell with barcode into the round cell shaft until it clicks into place.
Align the line mark to the notch of the photometer.

The photometer reads the barcode of the round cell and automatically selects the relevant method.

After approx.
2 s:

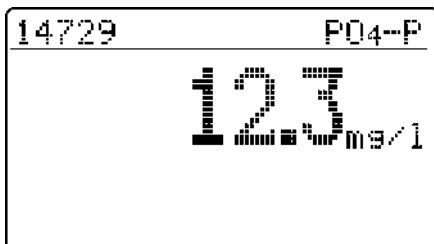

The measured value appears on the display.



If the *select method* menu is displayed, align the line mark of the round cell to the notch of the photometer.

4. Measuring the Concentration

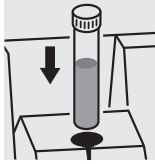

4.3 Measuring using tests without barcode (manual method selection)

When measuring using cell tests without barcode, the method must be selected manually.



```
select method
-----
method: 286
                14729
                PO4-P
#          0.5-25.0 mg/l
```

The last method set up manually appears on the display.

- Select the required method with 
- Confirm with .

```
14729          PO4-P
-----
measuring...
```

After approx.
2 s:

```
14729          PO4-P
-----
          123
          mg/l
```

The measured value appears on the display.

5. Measuring the Absorbance/Transmission

5.1 Switching to the Absorbance/ Transmission measuring mode

- Call up the *setup* measuring mode by actuating .

```
Setup
-----
documentation
method Parameter
▶abs./trm. %
meter setup
```

- In the *setup* menu, call up the *abs./trm. %* submenu.

```
absorbance  *
transmission
return
```

Selection of the measuring mode:

- *absorbance*
- *transmission*

5.2 Measuring the absorbance or transmission

- Call up the *absorbance* or *transmission* measuring mode (depending on the selection in the *abs./trm. %* menu) by actuating .

```
Absorbance
-----
insert cell
```

Measuring mode, *absorbance*

```
transmission
-----
insert cell
```

Measuring mode, *transmission*

i The transmission measurement is not described separately in the following example as it operates in exactly the same way as the absorbance measurement. However, the result of the measurement is displayed as % Transmission instead of A for Absorbance.

i A measured reference absorbance is also effective in the measuring mode, *transmission*. It is displayed as reference absorbance.

5. Measuring the Absorbance/Transmission

5.3 Measuring using cell tests

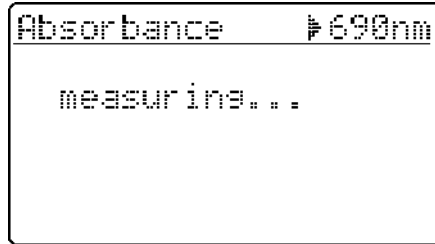
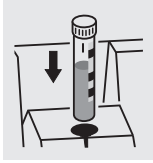

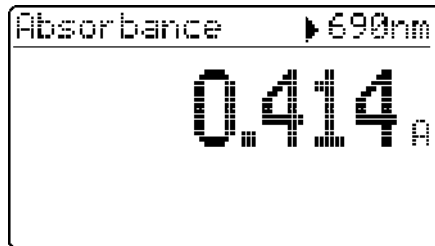

- Insert the round cell with barcode into the round cell shaft until it clicks into place. Align the line mark to the notch of the photometer.

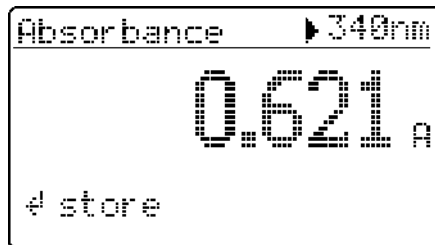

- The measured value for the wavelength displayed at the top right appears. This measured value is automatically stored. If necessary, call up further wavelengths:

– with .



- The measured value for the selected wavelength appears and can be stored and output to the interface with .



- Sample display for transmission measurement

5.4 Measuring using tests without barcode

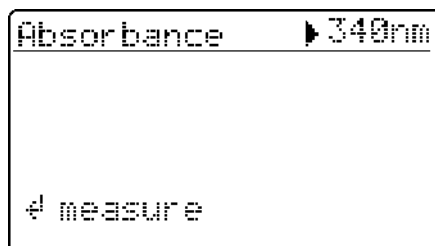
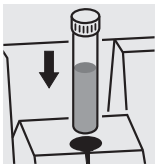

- The last wavelength measured appears on the display.

- Select the wavelength:

with .

- Start the measurement:

Press .

6. Documentation

The measured values can be documented as follows:

- Storage in the measured value memory
 - Output to a connected printer via the serial interface (automatic when a printer is connected)
 - Transmission to a PC for further processing (by using the relevant software, e.g. Multi/ACHATII or – less conveniently – by means of a terminal program).
- To switch on the photometer, open the cover.
- Press .

The following display appears:

```
Setup
-----
|documentation
|method Parameter
|Meter Setup
```

```
documentation
-----
|no. of meas. value
|download memory
|output methods
|return
```

- Call up the *documentation* menu with .

The following functions can be selected:

- *no. of meas. value*
 - reset the number
- *download memory*
 - total
 - from date
- *output methods*
 - all

The current settings are marked by "◆" in the selection lists of the respective submenus.

6. Documentation



6.1 Resetting the number of the measured value

```
documentation
└─no. of meas. value
   download memory
   output methods
   return
```

```
no. of meas. value
reset number:
└─Yes  +
   No
   return
```

- Call up the *no. of meas. value* submenu.

- *yes*
The numbering of the measured values starts again with 001 (default)
- *no*
Consecutive numbering of the measured values (from 001 to 999)

- Select the menu item with 
- Confirm with 

6.2 Download memory

The measured value storage can be selectively downloaded to either the display or serial interface. The selection of the output medium is made after the specification of the sorting criteria.



```
documentation
└─no. of meas. value
   └─download memory
      download memory
      output methods
      return
```

```
download memory
└─total
   from date
   return
```

- Call up the *download memory* submenu.

 The *download memory* menu item only appears after at least one measurement has been performed.

The following sorting criteria can be set:



- *total* – all stored measured values
 - *from date* – all measured values from a special date
- Select the menu item with 
 - Confirm with 

6. Documentation

Selecting "total"



```
download memory
┌───────────────────┐
│▶to display        │
│to printer/PC     │
│return            │
└───────────────────┘
```

Select the output medium:

- *to display*
- *to printer/PC* (serial interface).
- Select the menu item with 
- Confirm with  to start the memory download.



Selecting "from date"

```
download memory
┌───────────────────┐
│from date: 07.02.98 │
│                     │
│◀                   │
└───────────────────┘
```

- Input the date using 
- Erase the input using 
- Confirm with .

```
download memory
┌───────────────────┐
│▶to display        │
│to printer/PC     │
│return            │
└───────────────────┘
```

Select the output medium:

- *to display*
- *to printer/PC* (serial interface).
- Select the menu item with 
- Confirm with  to start the memory download.

Memory download to display

```
download memory
┌───────────────────┐
│009  07.05.97 17:24 │
│Feed      14554 Ni  │
│           3.66 mg/l │
│◀ return          AQA2 │
└───────────────────┘
```

Each data record appears individually on the display beginning with the data record just measured.

The display shows:

- no. of meas. value
- date/time
- I. D. number
- method designation
- citation
- meas. value
- unit
- Where necessary, AQA ID, e.g. AQA2.

- Scroll with .

6. Documentation

Memory download to printer/PC

```
download memory
data transmission
runs:
          121
← cancel
```

Memory download to the serial interface:

- Display of the transmitted no. of measured value (continuation display) beginning with the last measured value.
- Cancel with .

Sample printout:

003	14541	10.02.98	11:56:33	t	80	mg/l	COD
002	14541	10.02.98	11:54:21	t	70	mg/l	COD
001	14729	03.02.98	18:30:53	*	0.3	mg/l	PO4-P

6.3 Download of the methods list



The stored methods are downloaded to the printer/PC via the serial interface.

```
documentation
no. of meas. value
download memory
output methods
return
```

- Call up the *output methods* submenu.

```
output methods
all
return
```

The following parameters can be set:

- *all* – Download of all stored methods
- Select the menu item with .
- Start the download with .

7. Method Parameters

The following parameters can be set in the *method parameters* menu:

- citation
- unit

- To switch on the photometer, open the cover.
- Press .

The following display appears:

```
Setup
-----
documentation
▶method Parameter
AQA-Check
Meter Setup
```

```
method parameter
-----
method: 286
                14729
                P04-P
↓          0.5-25.0 mg/l
```

```
method parameter
-----
▶Citation
Dilution
return
```

- Call up the *method parameters* submenu.

- Input the method number

- Confirm with .

- Select the menu item with .

- Call up the parameter by pressing .

7. Method Parameters

7.1 Citation form

7.1.1 Changing the citation form

Example:

Change the citation form from "NH₄-N" to "NH₄".

```
method parameter
└─ Citation
   Dilution
   return
```

– Call up the *citation* submenu.

```
Citation 14739
└─ NH4-N ⚡
   NH4
   return
```

The current setting: NH₄-N (⚡).

```
Citation 14739
  NH4-N ⚡
└─ NH4
   return
```

– Using , scroll to NH₄

– Confirm with .

```
Citation 14739
  NH4-N
└─ NH4 ⚡
   return
```

– Citation form NH₄ is set (⚡).

7. Method Parameters

7.1.2 Performing a difference measurement

Difference measuring is possible for some methods (e.g. Iron II/III, Ca-/Mg Hardness).

 For more information on this, see part, "Analysis specifications".

Example:

Determination of iron (II) and iron (III).

```
method parameter
-----
method: 106
                        14896
                        Fe
↓                      1.0-50.0 mg/l
```

- Enter method 106
- Confirm with .

```
method parameter
-----
▶Citation
Dilution
return
```

- Call up the *citation* menu item.

```
Citation                14896
-----
▶Fe ↓
FeII,FeIII Δ
return
```

The current setting: Fe

- Using  scroll to Fe II, Fe III Δ
- Confirm with .

```
Citation                14896
-----
Fe
▶FeII,FeIII Δ ↓
return
```

- Citation form Fe II, Fe III Δ (↓) is set.

- Change to measuring by pressing .

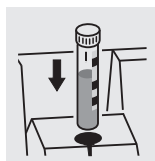

```
14896   FeII,FeIIIΔ
-----
Σ Fe
measuring...
```

- Start the 1st measurement by inserting cell 1.

7. Method Parameters

After approx.
2 s:

14896	FeII,FeIII Δ
3.2 mg/l	
Σ Fe	
# FeII	

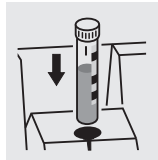

14896	FeII,FeIII Δ
FeII	
measuring...	

After approx.
2 s:

14896	FeII,FeIII Δ
2.1 mg/l	
FeII	
# FeII,FeIII	

14896	FeII,FeIII Δ
FeII	2.1 mg/l
FeIII	1.1 mg/l

The 1st measured value appears on the display: Σ Fe.

– Remove cell 1

– Press .

– Start the 2nd measurement by inserting cell 2.

The 2nd measured value appears on the display:
Iron II.

– Continue to the display of both measured values

using .

Display of both measured values as a summary.

7. Method Parameters

7.2 Selecting the unit



The preset unit is "mg/l".
It can be changed to "mmol/l".

```
method parameter
Citation
▶unit
return
```

- Call up the *unit* submenu.

```
unit 14729
▶mg/l +
mmol/l
return
```

The current setting: *mg/l* (+)

- Using  scroll to *mmol/l*
- Confirm with .

```
unit 14729
mg/l +
▶mmol/l
return
```

- Unit *mmol/l* (+) is set.

8. Analytical Quality Assurance (AQA)

Analytical quality assurance (AQA) can be performed in two steps:

- **AQA1** – Photometer monitoring
- **AQA2** – Total system monitoring with standard solutions



The total system monitoring (AQA2) is a method-specific check using standard solutions.

If this is performed successfully, it also includes photometer monitoring (AQA1).

See also part "General information" for further information on Analytical Quality Assurance (AQA).

The AQA mode must be activated in the photometer. In the delivery state it is switched off.

The AQA mode is activated by using a menu to select

- monitoring of the photometer (AQA1)
- monitoring of the total system using standard solutions (AQA2)

8.1 Activating AQA

- To switch on the photometer, open the cover.

8.1.1 Activating AQA via the menu guide

- Press

```
Setup
-----
documentation
method parameter
▶Meter Setup
```

- Call up the *meter setup* submenu.

```
meter setup
-----
return
▶AQA functions
correction funct.
adjust zero
set date/time
```

The *meter setup* submenu appears with the *AQA functions* menu item preselected.

- Confirm with

A password request appears:

```
AQA-Configuration
-----
input password:

  0 0 0 0
```

A separate password protects settings of the AQA-configuration against unauthorized access (Changing the password see section 8.1.5).

- Input the password with :
Only **numeric** characters are allowed.
Default: 0000
- Confirm with

If the input was incorrect:

8. Analytical Quality Assurance (AQA)

```
AQA-Configuration
-----
wrong Password
```

- Repeat the input.



If you have forgotten the password, contact the service department.

After the password has been successfully input, the *AQA configuration* submenu appears:

```
AQA-Configuration
-----
return
▶AQA-Mode
AQA-Standards
AQA-Intervals
System locked
```

- Call up the *AQA mode* function.

```
AQA-Mode
-----
▶off *
n weeks
n measurements
return
```

Default: *off* (no monitoring)

- Select *AQA mode*:
 - *off*
 - *n weeks*
 - *n measurements*

- Confirm with .

```
Setup
-----
documentation
method Parameter
▶AQA-Check
Meter Setup
```

- In the *setup* menu, call up the *AQA check* submenu.

```
AQA-Check
-----
Meter
▶system
return
```

Selection of the *AQA mode*:

- *meter*
- *system*



The menu item, *meter*, only appears after the corresponding PhotoCheck standards have been input (see section 8.2.1).

8. Analytical Quality Assurance (AQA)

8.1.2 Changing AQA intervals

AQA intervals specify the interval between two AQA checks. A fixed time interval (*n weeks*) or a number of measurements (*n measurements*) can be specified as the interval.

The respective values that were input remain stored even if they are not activated.

Additionally, two separate intervals can be set up for both photometer monitoring (AQA1) and system monitoring (AQA2).



For the total system monitoring (AQA2), a change of the time interval (*n weeks*) even retroactively applies to monitoring processes that are already running.

Changing the number of measurements (*n measurements*) does not affect monitoring processes already running.

Thus, individual numbers of measurements can be set for different methods.

```
AQA-Configuration
-----
return
AQA-Mode
AQA-Standards
AQA-Intervals
System locked
```

After an interval has expired, the following consequences become effective:

- Warning and loss of AQA identification
- Locking of the method for concentration measurements (as long as the locking is active).

Setting ranges:

- Photometer monitoring (AQA1):
 - 1 to 52 weeks (default: 12 weeks) or
 - 1 to 9999 measurements (default: 1500)
- Monitoring of the total system using standard solutions (AQA2):
 - 1 to 52 weeks (default: 4 weeks) or
 - 1 to 9999 measurements (default: 100)



With the *n measurements* setting, a difference measurement (see section 7.1.2) is counted as one measurement only.

- In the *AQA configuration* menu, call up the *AQA intervals* submenu. According to the selection in the *AQA mode* menu, a fixed time interval (*n weeks*) or a number of measurements (*n measurements*) is set in the *AQA intervals* menu.



If the *AQA mode* function is switched off, the *AQA intervals* submenu is not available.

AQA interval, "n weeks"

The AQA interval, *n weeks*, is only effective if the *n weeks* setting is active for the *AQA mode* function.

The specified number of *n weeks* applies to:

- the photometer with AQA1
- all methods with AQA2.

- In the *AQA intervals* menu, call up the *n weeks* submenu.

```
AQA-Intervals
-----
AQA-Meter: 12 w
AQA-System: 04 w
confirm
```

- To return without change, press three times
- Enter the time interval for *AQA meter* with , confirm with .

8. Analytical Quality Assurance (AQA)

AQA interval, "n measurements"

The AQA interval, *n measurements*, is only effective if the *n measurements* setting is active for the *AQA mode* function.

The AQA2 check starts the monitoring for one method at a time.

The specified number of *measurements* applies to:

- the instrument with AQA1 (total number of measurements performed, independent of whether AQA2 is active for some parameters)
- each method an AQA check will then be performed for with AQA2.
Thus, it is possible to define individual numbers of measurements for different methods.
The measurements are counted separately for each monitored method.

The monitoring intervals of AQA2 monitoring processes already started for other methods are not affected by changing the number of *measurements*. Thus the number of *measurements* can be set for further methods no matter which monitoring processes were started before.







When an AQA2 check is performed, the number of *measurements* last set in the *AQA intervals* menu is automatically taken over.

Therefore, you should check and, if necessary, change the currently set number of *measurements* before each AQA2 check.

The currently set number of *measurements* for the AQA2 check is saved for the active method and output in the report individually (section 8.3.4).

- In the *AQA intervals* menu, call up the *n measurements* submenu.

```
AQA-Intervals
-----
AQA meter:
  1500 measurements
AQA system:
  0100 measurements
← confirm
```

- To return without change, press  three times
- Enter the number of measurements for *AQA meter* with , confirm with 
- Enter the number of measurements for *AQA system* with , confirm with 

8. Analytical Quality Assurance (AQA)

8.1.3 Locking the system

The function *system locked* is effective if, for a monitored method,



- no AQA check was performed,
- the AQA check “system” has expired.

As a result, a concentration measurement is not possible for this method.

```
AQA-Configuration
return
AQA-Mode
AQA-Standards
AQA-Intervals
▶System locked
```

- Call up the *system locked* submenu.

```
System locked
off
▶on      +
return
```

- Select the menu item with 
- Confirm with .

8. Analytical Quality Assurance (AQA)



8.1.4 Changing the password

When delivered, the default password is *0000*. This password can be changed as follows:

```
AQA-Configuration
-----
AQA-Standards
AQA-Intervals
System locked
change Password
reset
```

- Call up the *change password* submenu.
- Confirm with .

```
AQA-Password
-----
input password:
(0000)
0000
```

- Input the required password, e.g. *0100*, with .
- Confirm with .

```
AQA-Password
-----
confirm password:
(0100)
0000
```

- Input the password once again:
- Confirm with .

8.1.5 Performing an AQA reset

If the Analytical Quality Assurance is to be switched off completely or reset to the delivery state, this can be made via the *reset* function in the *AQA configuration* submenu.

```
AQA-Configuration
-----
AQA-Intervals
System locked
change Password
reset
return
```

- Call up the *reset* submenu
- Confirm with .

```
AQA-Configuration
-----

reset
cancel
```

- Select the *reset* menu item
 - Confirm with .
- An AQA reset is performed.

8. Analytical Quality Assurance (AQA)

8.2 Photometer monitoring (AQA1)

8.2.1 Entering PhotoCheck standards



A Spectroquant® PhotoCheck is required to perform the photometer monitoring (AQA1). **At least 1 standard** must be input. We recommend, however, to input all available standards.

- Press to call up the *setup* menu
- Call up the *meter setup* submenu.
- Call up the *AQA functions* submenu.
- Input the password
- Call up the *AQA standards* submenu and the following display appears:

```
AQA-Standards
├─ PhotoCheck
│   standard solution
│   return
```

```
PhotoCheck-Standards
├─ input
│   output
│   erase
│   return
```

- Call up the *PhotoCheck* submenu.

Select between

- *input*
Input the theoretical value (absorbance) from the lot certificate of Spectroquant® PhotoCheck
- *output*
Print/display theoretical values
- *erase*
Erase theoretical values.





The *erase* and *output* menu items only appear after at least one standard has been input.

8. Analytical Quality Assurance (AQA)

Example:

445-1 nm, theoretical value (absorbance) 0.200,
admissible tolerance ± 0.020

```
PhotoCheck-Standards
return
▶445-1
 445-2
 445-3
 445-4
```



- Select with 
- Quit via the menu item, *return*
- Confirm with .

```
PhotoCheck      445-1
theor.val.: 0.200 A
elconfirm
```

- Input the theoretical value, 445-1
- Confirm with .

If the standard is already stored, this value appears on the display.

```
PhotoCheck      445-1
theor.val.: 0.200 A
Tolerance: ±0.020 A
elconfirm
```

- Input the tolerance with 
- Confirm with .

```
PhotoCheck-Standards
return
▶445-1 ✓
 445-2
 445-3
 445-4
```

PhotoCheck standard 445-1 is input.

- Select the next one with 
- Input all PhotoCheck standards in this way.

8. Analytical Quality Assurance (AQA)



8.2.2 Download of PhotoCheck standards

```
PhotoCheck-Standards
input
output
erase
return
```

- In the *PhotoCheck standards* submenu, call up the *output* menu item.

```
download PhotoCheck
to display
to printer/PC
return
```

Select the output medium:

- to display
- to printer/PC (serial interface).
- Select with 
- Confirm with  to start the download.

Example: Report output

AQA check meter
26.08.97

AQA1
13:19

AQA interval

12 weeks

test sol.	unit	theor. val.	tolerance	AQA date
445-1	A	0.200	0.020	26.08.97

8.2.3 Erasing PhotoCheck standards



At least 1 standard must still be stored to be able to perform the AQA check function (meter monitoring).

```
PhotoCheck-Standards
input
output
erase
return
```

- In the *PhotoCheck standards* submenu, call up the *erase* menu item.

```
erase PhotoCheck
445-2
445-3
445-4
return
```

Displays the stored PhotoCheck standards:

- Select with 
- Quit via *return*
- Erase with .

8. Analytical Quality Assurance (AQA)

8.2.4 Performing Photometer monitoring

Photometer monitoring (AQA1) includes a check of the

- Light barriers using the L1/L2 cells (contained within the scope of delivery of the Spectroquant® PhotoCheck)
- Absorbance measurement using PhotoCheck

standards.

- Press  to call up the *setup* menu
- Call up the *AQA check* submenu
- Call up the *meter* submenu.

The following display appears:

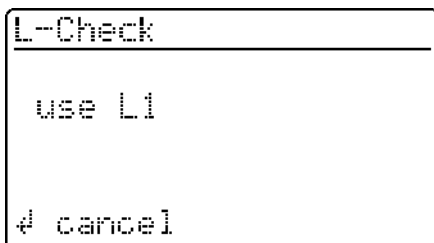

```
L-Check
-----
use L1
      ↵ cancel
```

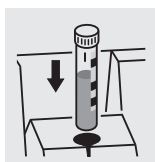

After approx.
1 s:

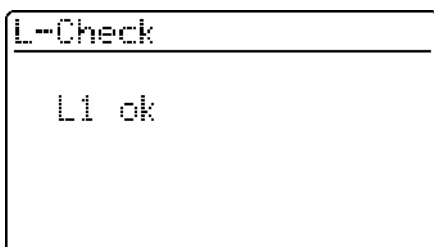

```
L-Check
-----
L1 ok
```

After approx.
4 s:

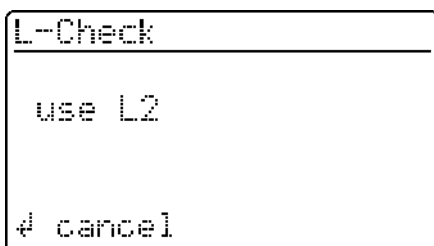

```
L-Check
-----
use L2
      ↵ cancel
```

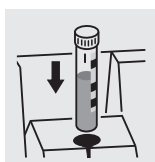

After approx.
1 s:

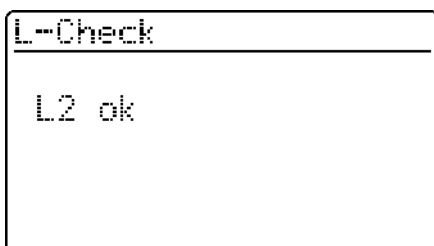

```
L-Check
-----
L2 ok
```

- Insert the L1 cell.



If the *error* message appears, clean the cell shaft with a damp, lint-free cloth and repeat the check.

If the message reoccurs, inform the service department.

- Insert the L2 cell.

8. Analytical Quality Assurance (AQA)

After successful light barrier testing, the PhotoCheck standards (test solutions) are measured.

Example:

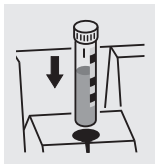

```
PhotoCheck      445-1
-----
use test
solution      445-1
↵ cancel
```

- Insert a cell with the test solution, 445-1. The photometer measures the absorbance of the test solution and compares the result with the value entered.

Absorbance test OK...

After approx.
3 s:

```
PhotoCheck      445-1
-----
0.211 A
ok
```

- Insert the next test solution
- Cancel:
To cancel the check means no release for the next "meter" AQA interval!

...or error message

```
PhotoCheck      445-1
-----
----- A
Error
```

Error elimination:

1. Repeat the measurement (insert the cell again)
2. If necessary, perform a zero adjustment and repeat the check
3. Exchange the test solution (each packet contains two identical test solutions)
4. Use a new Spectroquant® Photo-Check packet
5. Quit and have the photometer checked in the factory

The absorbance test is terminated if an error message occurs and the meter is **not released**. On switching on, the warning message "AQA interval expired" appears until the AQA was successfully performed or the AQA mode was switched off.

Example: Report output

AQA check meter	26.08.97	operator:	AQA1	10:23		
AQA interval	AQA check AQA1	L check	12 weeks	ok	ok	
test sol.	meas. value	unit	theor. val.	tolerance	result	
445-1	0.211	A	0.200	0.020	ok	

8. Analytical Quality Assurance (AQA)

8.3 Total system monitoring with standard solutions (AQA2)

8.3.1 Entering standards



The standards compiled in the table "Spectroquant® CombiCheck and standard solutions" (see part "General information") are already stored method-specifically in the photometer. These values can be overwritten.

For **total system monitoring** (AQA2), only one standard per test can be stored at a time. The input of a standard is only complete with the input of the tolerances for finding it again, i.e. it is then first stored (no premature quitting).

- Press  to call up the *setup* menu
- Call up the *meter setup* submenu.
- Call up the *AQA functions* submenu
- Input the password
- Call up the *AQA standards* submenu and the following display appears:

```
AQA-Standards
PhotoCheck
▶standard solution
return
```

```
standard solution
▶input
output
erase
return
```



```
input standard
method: 2B6
14729
PO4-P
↓ 0.5-25.0 mg/l
```

- Call up the *standard solutions* submenu.

Select between

- *input*
Enter standards
- *output*
Print/display standards
- *erase*
Erase standards.

Displays the last selected method.

- Select the method with 
- Confirm with 
- Input the standards.

8. Analytical Quality Assurance (AQA)

Example:

Method 14729 with a preset theoretical value of 15.0 mg/l and tolerance of 1.0 mg/l (CombiCheck 80).

Change to: theoretical value = 8 mg/l, tolerance = 0.7 mg/l (CombiCheck 20).

```
input standard
-----
method: 136
                14729
                P04-P
↓      0.5-25.0 mg/l
```

– Confirm with .

```
standard      14729
-----
theor.val.: 15.0 mg/l
              (06.3-18.8 mg/l)
↓ confirm
```

– Enter the new theoretical value, e.g. 8.0 mg/l, with .

Values in parentheses indicate the range in which the theoretical value should move.

– Confirm with .

```
standard      14729
-----
theor.val.: 08.0 mg/l
Tolerance: ±1.0 mg/l
↓ confirm
```

– Input the tolerance (0.7 mg/l) with .

– Confirm with .

```
standard      14729
-----
theor.val.: 08.0 mg/l
Tolerance: ±0.7 mg/l
↓ confirm
```

Both standard and tolerance values have been overwritten.

– Confirm with .

8. Analytical Quality Assurance (AQA)

8.3.2 Output of standards

The current list of stored standards is output via the RS 232 interface (PC/printer) or via the display.

```
standard solution
input
output
erase
return
```

- Select the *output* submenu
- Confirm with .

```
download Standard
to display
to printer/PC
return
```

Select the output medium:

- *to display*
- *to printer/PC* (serial interface).

- Select with .
- Confirm with  to start the download.

Example: Report output

AQA check system		AQA2		
26.08.97		13:57		
system locked		on		
method	unit	theor. val.	tolerance	AQA date
14554	mg/l	2.00	0.20	24.08.97
14555	mg/l	5000	400	26.08.97

8. Analytical Quality Assurance (AQA)



8.3.3 Erasing standards

Erasing the method-specific standard solutions leads to the change of the measured value identification from AQA2 to AQA1 (with activated AQA mode).



```
AQA-Standards
PhotoCheck
▶standard solution
return
```

- Call up the *standard solutions* submenu.

```
standard solution
input
output
▶erase
return
```

- Select the *erase* menu item, *erase* with 
- Confirm with 

```
erase standard
▶14560
14729
return
```

- Select the standard to be erased with 
- Erase with 

8.3.4 Monitoring of the total system using standard solutions

The AQA2 check can be performed after it has been activated (see section 8.1).

The following display appears:

```
AQA-Check
insert cell
```

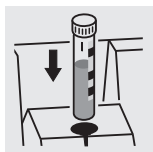

- i** For AQA2 with the setting, *n measurements*, we recommend to check and, if necessary, change the currently set number of *measurements* before each AQA check (8.1.2 CHANGING AQA INTERVALS).
- Insert cell with prepared solution ready to be measured (e.g. using Spectroquant® Combi-Check). The photometer reads the barcode, identifies the method and performs the AQA2 check.

8. Analytical Quality Assurance (AQA)

After approx.
2 s:

AQA check OK ...

AQA-Check	14554
1.93 mg/l ok	

...or error message

AQA-Check	14554
3.45 mg/l Error	

- Repeat the check
If the error is repeated, perform troubleshooting of the error. See "Analytical Quality Assurance" in part "General information".



The *system* AQA2 check must be performed **separately** for each method monitored. The release is stored with the date and the specified interval. The AQA2 interval *system* set up for the respective method begins again.

Example: Report output (AQA mode: *n weeks*)

AQA check system			AQA2		
26.08.97			11:02		
operator:					
AQA interval			4 weeks		
method	meas. value	unit	theor. val.	tolerance	result
14554	1.95	mg/l	2.00	0.20	ok

Example: Report output (AQA mode: *n measurements*)

AQA check system			AQA2		
26.08.97			11:02		
operator:					
AQA interval			100 measurements		
method	meas. value	unit	theor. val.	tolerance	result
14554	1.95	mg/l	2.00	0.20	ok

9. Correction functions

- To switch on the photometer, open the cover.
- Press .
- In the *setup* menu, call up the *meter setup* submenu.
The following display appears:

```
Meter Setup
-----
return
AQA Functions
▶Correction Funct.
adjust zero
set date/time
```

- Call up the *correction funct.* submenu.

The following display appears:

```
Correction Funct.
-----
▶Blank Value
Turbidity Correct.
return
```

Select the correction function:

- blank value
- turbidity correct.
- Confirm with .

9.1 Blank value

The blank value (= reagent blank value) for each method is stored in the photometer. When the *blank value* function is active, the stored value is ignored and the measured value of a self-prepared reagent blank solution is used instead.

This procedure increases the measuring accuracy for some tests (for more information, see part "Analytical procedures").

A blank value is always stored for the method that was just called up.

A blank value remains stored until it is erased (menu item, *erase blank value*) or overwritten.

The *reset setup* function sets the *blank value* to *off*. The stored blank values, however, remain stored.

The *reset total* function resets all settings and blank values at once.

If a measured blank value is stored and the *blank value* function is active for a method, this blank value is used for determining the measured value and the measured value is documented accordingly.

The *blank value* function is not active when delivered.

9. Correction functions

Measuring the concentration with a blank value

- Press  to call up the *concentration* measuring mode.

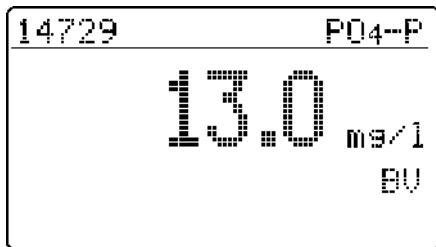



The value measured against the prepared blank solution is displayed.

9.1.1 Activating the blank value measurement

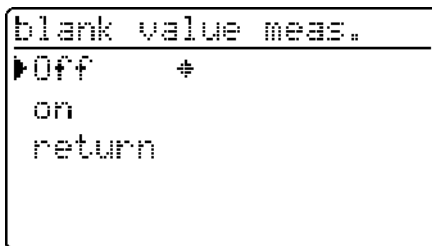
- In the *correction funct.* menu, call up the *blank value* submenu. The following display appears:



The *blank value meas.* function appears:

- Select the *on* menu item with 
- Confirm with .

i The stored blank values determined from blank solutions prepared by the user can be deactivated by switching off the blank value measurement. When doing so, the blank values remain stored in the memory and can be reactivated later.

Activating or deactivating the blank value function applies to all measurements using methods a blank value was stored for in the memory.

The *blank value* function is active and appears in the *setup* menu:

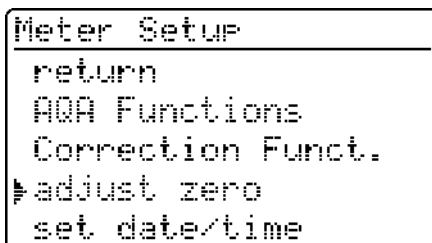

- To measure the blank value, call up the *blank value* submenu in the *setup* menu.

9. Correction functions

9.1.2 Measuring the blank value

```
Blank Value
┌───────────┴───────────┐
│ meas. blank value      │
│ erase blank value      │
│ recall blank values    │
│ return                 │
└───────────┴───────────┘
```

- Call up the *meas. blank value* menu item.

i The menu items, *erase blank value* and *recall blank values* first appear after at least one blank value has been measured.

```
meas. blank value
┌───────────┴───────────┐
│ insert cell           │
└───────────┴───────────┘
```

- Insert a cell with blank solution to start a measurement. The message, *measuring...*, appears on the display.

After approx.
2 s:

```
Blank Value      14729
┌───────────┴───────────┐
│                      │
│      0.033 A         │
│                      │
│ ↵ return             │
└───────────┴───────────┘
```

9.1.3 Erasing blank values

A measured blank value is erased via the menu item, *erase blank value*.

```
Blank Value
┌───────────┴───────────┐
│ meas. blank value      │
│ erase blank value      │
│ recall blank values    │
│ return                 │
└───────────┴───────────┘
```

- Select the *erase blank value* menu item
- After confirming with  the *erase blank value* menu opens.

i The *erase blank value* menu item first appears after a blank value has been measured.

```
erase blank value
┌───────────┴───────────┐
│ all                    │
│ ↵ single                │
│ return                 │
└───────────┴───────────┘
```

Select between





- *all*
Erase all stored blank values
- *single*
Erase individual stored blank value

9. Correction functions

```
erase blank value
12.01.2004 14:57
14758
0.100 A
e!
```

```
erase blank value
12.01.2004 14:57
14758
erase
cancel
```





i Each stored blank value is displayed with the date of the blank value measurement and the relevant method designation.

- Select the blank value with 
- Erase the displayed blank value with 
- Select the *erase* menu item with 
- Confirm with 

9.1.4 Recalling blank values

```
Blank Value
meas. blank value
erase blank value
recall blank values
return
```

```
recall blank values
12.01.2004 14:57
14758
0.100 A
ereturn
```

- Select the *recall blank values* menu item with 
- Confirm with 
- Select the blank value with 
- Return with 

9. Correction functions

9.2 Turbidity correction

Turbidity correction is used in sample solutions that contain finely distributed suspended particles. The suspended particles cause a light absorption. This leads to incorrect (too high) measured values. The function remains permanently switched on after it has been activated. Values that were measured using turbidity correction are given an identifier in the **display** and in the **documentation** (printout and storage).

- In the *correction funct.* menu, call up the *turbidity correct.* submenu.

The following display appears:

```
Turbidity Correct.
Off
on
return
```

- Press  to call up the *concentration* measuring mode.

```
Concentration
insert cell
```

After approx.
2 s:

```
14542 NO3-N
13.3 mg/l
TC
```

Warning of excessive turbidity:

If the turbidity absorbance of $0.100 A$ is exceeded, the meter displays the measured value together with a warning.



```
14542 NO3-N
high turbidity!
TC 43 mg/l
```

The *turbidity correct.* function is not active when delivered.



This function is not necessary, or useful, in all methods. If the turbidity correction is active, the photometer automatically decides whether to perform the function or not depending on the method.

The *turbidity correct.* function appears:

- Select the *on* menu item with 
- Confirm with 

- Insert the measuring cell.

Display of the measured value with turbidity correction switched on: Identified by *TC*.

10. Zero adjustment

Zero adjustment is necessary

- after changing the lamp
- after the error message, *PhotoCheck* (AQA1) occurs
- on initial commissioning
- if the photometer was mechanically stressed, e.g. percussion, transport
- if the ambient temperature changed by more than 5 °C since the last zero adjustment
- at least every six months.



Only perform the zero adjustment against distilled water in an optically perfect cell.

- Press 
 - In the *setup* menu, call up the *meter setup* submenu.
- The following display appears:

```
meter setup
-----
return
AQA functions
correction funct.
▶adjust zero
set date/time
```

```
adjust zero
-----
insert cell
```

After approx.
2 s:

```
adjust zero
-----
round ok
```

When performing the zero adjustment observe the following points:

- Only use a clean, scratch-free round cell with distilled water. A prepared zero cell is provided with your photometer. In addition, a prepared zero cell is contained in the scope of delivery of the *PhotoCheck* (article 14693).
- If the round cell is visibly contaminated, or at least every 24 months, clean and refill it (minimum filling level 20 mm). Then check the cell for scratches.

- Call up the *zero adjustment* submenu with .

- Insert a cell with distilled water.
- The message, *measuring...*, appears on the display.

Successful zero adjustment

11. Meter Setup

- To switch on the photometer, open the cover.
- Press 
- In the *setup* menu, call up the *meter setup* submenu.
The following display appears:

```
meter setup
-----
return
▶AQA functions
correction funct.
adjust zero
set date/time
```

This chapter describes four functions of the *meter setup* menu:

- *select language*
- *set date/time*
- *Performing a meter reset*
- *system info*

11.1 Selecting the language

The following languages are stored in the photometer:

- Deutsch (German)
- English
- Français (French)
- Italiano (Italian)
- Português (Portuguese)
- Polski (Polish)
- Dansk (Danish)
- Svenska (Swedish)
- Español (Spanish)
- Nederlands (Dutch)
- Indonesia (Indonesian)
- Čeština (Czech)
- Magyar (Hungarian)
- Russkij (Russian)
- Türkçe (Turkish)
- Brasil (Brazilian)



This is the order in which the available languages appear in the *select language* menu.



The available languages are listed in the language of the respective country in the photometer.

When *Russkij* is selected as the language, the Cyrillic alphabet is used for the user guidance. Method designation and ID numbers are always displayed in Latin script. For output to the RS 232 C interface, Cyrillic characters are converted to Latin characters according to GOST.

```
meter setup
-----
correction funct.
adjust zero
set date/time
▶select language
system info
```

- Call up the *select language* menu item.

```
select language
-----
return
Deutsch
▶English
Français
Italiano
```

- Select a language, e.g. English
- Confirm with 
- Press the  key again:
Return to the *meter setup* submenu.
The displays appear in English.

11. Meter Setup

11.2 Setting the date/time

```
Meter Setup
-----
AQA Functions
Correction Funct.
adjust zero
▶set date/time
select language
```

```
Date/Time
-----
Date      01.01.98
          (dd.mm.yy)
Time      16:45
          (hh:mm)
e confirm
```

– Call up the *set date/time* menu item.

– Input the date using 

– Confirm with 

– Input the time with 

– Confirm with .

11.3 Reset

It is possible to reset the photometer to its factory settings (delivery state) in single steps. The *reset total* function resets all settings and blank values at once.



All AQA functions are retained when *meter setup* is used. See section 8.1.5 for AQA reset.

```
Meter Setup
-----
set date/time
select language
system info
▶reset
return
```

```
reset
-----
▶total
meas. storage
Setup
return
```

– Call up the *reset* menu item.

Select between

- *total*
Erase the measured value storage and reset the settings to the delivery state
- *meas. storage*
Erase the measured value storage
- *setup*
Reset all settings to the delivery state.

Example: Performing a total reset

```
reset
-----

reset total

▶reset
cancel
```

– Select the *reset* menu item

– Confirm with .

A meter reset is performed (measured value memory and setup).

11. Meter Setup

11.4 System info

```
Meter Setup
-----
adjust zero
set date/time
select language
system info
reset
```

– Call up the *system info* menu item.

```
Meter Setup
-----
Software: 3.15
methods: 33.00

return
```

Sample display

12. Updating method data

You will always find the latest method data for your photometer on the Internet. A method update contains all new test sets and methods respectively. Additionally, minor modifications of already existing methods are transferred with it. With a method update, you receive all new methods and, at the same time, can easily and conveniently update all method data.

The software provided for downloading contains the program file and method data. It can be downloaded from our homepage with a mouse click.

The files are packed in a self-decompressing archive file (*.exe) or in a zip file (*.zip) and can be decompressed after the download.

Carry out the update as follows:

To download and update the photometer method data via the built-in RS232 interface, you need the following:

- PC (Win 95 or higher) with Internet connection
- PC cable (available as an accessory)
- An *.exe or *.zip file from the Internet; contains the "UpdateMethodData.exe" program file and 6 method data files (pls6md.xxx, pls12md.xxx, plspekmd.xxx, nova30md.xxx, nova60md.xxx, nova400md.xxx; xxx = version).

- Switch on the photometer (open the cover).
- Switch on the PC.
- Download from the Internet the software including the method data (*.exe or *.zip) and copy it into a separate directory or on a floppy disk.
- Decompress the *.exe file with a double-click or decompress the *.zip file with Winzip.
- Connect the serial interfaces of the PC and photometer with the cable.
- Start the "UpdateMethodData.exe" program file by double-clicking. The "Update Method Data" window appears. In the upper half of the window there is the name of your photometer (among other things), behind it there is the method version in brackets (e.g. 8.00).



All method data are reloaded into the photometer with the update. The old method data are overwritten by this.

- Click on the "Search meter" button. The program automatically recognizes the connected photometer. Another "Update Method Data" window appears.
- Click on the "Start" button to start the method download. The process takes approx. 3 minutes. You can terminate it at any time by clicking on the "Cancel" button. In this case, however, the download has to be carried out once again completely so that the photometer can save the method data and is operative.

12. Updating method data

During the download, the following display appears on the photometer screen:

```
remote
```



You can check whether the new method data are stored in the photometer. To do so, proceed as follows:

```
Meter Setup
-----
adjust zero
set date/time
select language
system info
reset
```

```
Meter Setup
-----
Software: 3.15
methods: 33.00
return
```

- After the download, confirm the "Data successfully downloaded" message. The download is finished. The photometer returns to the *concentration* measuring mode.

- In the setup menu, call up the meter setup submenu.
- Call up the *system info* menu item.

Sample display (the software version is irrelevant here).

The method version (here: 33.00) has to agree with the method version for your photometer in the "Update Method Data" window during the download.

Error messages

Message	Meaning	Remedy
No meter found	Connection PC - photometer out of order or not available	<ul style="list-style-type: none">– Tightly connect the cable to the serial interfaces of the PC and photometer.– Use the correct cable
	Photometer not recognized	<ul style="list-style-type: none">– Select the photometer manually

13. RS 232 C interface

Via the interface, data can be

- output to a printer and
- exchanged with a personal computer (PC)

For this, the following items are available as accessories:

- Printer cable
- Printer
- Interface cable
- Communication software.

13.1 Principle course of the remote control

String to meter	Reply from meter	Operating mode
S <CR>	> <CR>	Remote (remote control)
Command xx (see 15.2 command list)	Reply string command xx <CR>	Remote (remote control)
.		
.		
.		
CLOC <CR>		Concentration measurement



The keyboard of the photometer is locked in the *remote* operating mode.

13.2 Command list

Command	Function
S	Begin communication
CLOC	Switchover to normal operation (concentration measurement)
CDAT [anz]	Reads out stored measured values; [anz] = number of the measured values to be output
CMES [MMM]	Measurement and transmission of the concentration value with date/time; [MMM] = method number (e.g. 086 for method 14729)
CEXT [LLL]	Measurement and transmission of the absorbance value for the wavelength; [LLL] = wavelength
CBLA [MMM]	Measurement and transmission of the sample blank value; [MMM] = method number
CCLB [MMM]	Erase measured sample blank values; [MMM] = method number



The error message, *Invalid command*, appears if commands are unknown or cannot be carried out (e. g. if optional parameters do not agree with the cell coding). Optional parameters [MMM] and [LLL] need only be input for uncoded cells.

13. RS 232 C interface

13.3 Output format of measured values

Character	Meaning
3	consecutive number (not required for interface commands CMES, CEXT and CBLA)
5	method designation
6	I. D. number
17	date and time
4	special characters
9	meas. value
10	unit
12	citation
4	AQA ID (AQA2/AQA1)

Notes:

Data fields are separated by spaces.
Character set: IBM, code page 437

Meaning of the special characters:

! = Measuring with blank value (concentration) or reference absorbance (absorbance)
t/T = Measurement with turbidity correction/with high turbidity
* = Measured value outside the measuring range
Q = AQA measurement

13.4 Data transmission

Baud rate	4800
Data bits:	8
Stop bits:	1
Parity:	none
Handshake:	Hardware
Max. cable length	15 m

13.5 Pin assignment

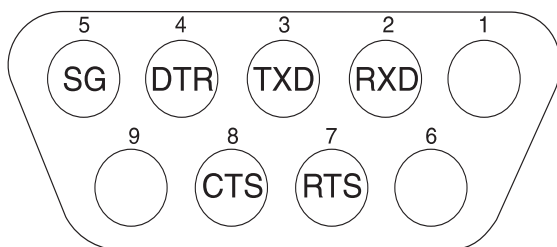

Photometer 9-pin socket	Computer 9-pin socket	25 pin plug	Printer with RS 232 C interface
1	4	20	-
2	3	2	TXD
3	2	3	RXD
4	1 and 6	6	-
5	5	7	SG
6	4	20	-
7	8	5	-
8	7	4	DTR (if not available: short-circuit CTS and RTS)
9		-	-

14. Maintenance, cleaning, disposal

14.1 Maintenance - Changing the lamp

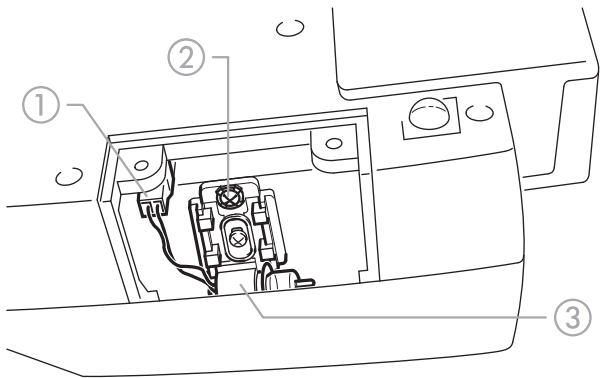

- Switch off the photometer and disconnect it from the power line
- Carefully turn up the photometer and park it safely
- Screw off the lamp cover on the underside of the photometer





Let the lamp of the photometer cool down.

- Pull out the plug ①
- Unscrew the screw ②
- Remove the lamp with its holder ③ by pulling it gently upwards



Do not touch the new light bulb of the photometer.

- Insert a new preset lamp and screw it tight using the screw ②

- Connect the plug ① of the new lamp
- Screw the lamp cover on again
- Set up the photometer again and connect it to the power line
- Press and hold 
- Switch on the meter (open the cover) and after the following display appears, release 

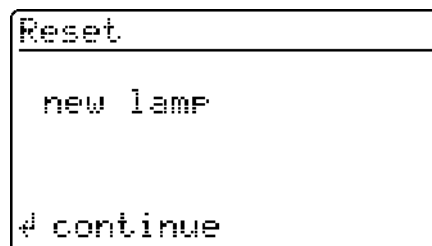

- Press 

14.2 Cleaning - Actions to take if a cell is broken



Do not rotate the photometer to pour out the liquid!

The photometer has a draining mechanism under the cell shaft that, when operated correctly, prevents any liquid coming into contact with electronic components.

- Switch off the photometer (close the cover) and disconnect it from the line power
- Let the liquid drain off
- Carefully remove any pieces of glass, e.g. using tweezers
- Carefully clean the cell shaft with a damp, lint-free cloth

- Let the cell shaft dry
After it is dry, check the photometer:
- Perform a photometer monitoring (see section 8.2).

▶ 14. Maintenance, cleaning, disposal

14.3 Disposal

Packing

The measuring instrument is sent out in a protective transport packing.

We recommend: Keep the packing material in case you have to send the measuring instrument back for service. The original packing prevents the measuring instrument from being damaged during transport.

Measuring instrument

Dispose of the measuring instrument as electronic waste at an appropriate collection point. It is illegal to dispose of it in household refuse.

Within the European Union, the batteries are removed at a specialized treatment center at the instrument's end of life. The instruments are taken to one of those specialized treatment centers via the recycling system set up for this purpose.

15. Technical Data

Optical measuring principle	Filter photometer with reference beam absorption measurement; simultaneous recording of all wavelengths
Light source	Tungsten halogen lamp, preset
Receiver	6 x photo diode array
Optical filters	340 nm, 445 nm, 525 nm, 550 nm, 605 nm, 690 nm, Accuracy: ± 2 nm; Half width: 340 nm = 30 nm ± 2 nm; all others = 10 nm ± 2 nm
Photometric reproducibility	0.001 A at 1.000 A
Photometric resolution	0.001 A
Warm-up time	none
Measuring time	approx. 2 s
Types of measurement	Concentration (method dependent, selectable display form), absorbance, transmission
Measuring range absorbance	-0.300 A to 3.200 A
Measuring range transmission	0.1 % to 1000 %
Balancing	Permanently stored
Drift correction	Automatic on each Self-Check
Retrofitting of new methods	via the Internet
Bar code recognition	automatic selection of the method; automatic recognition of the reagents lot
Cell recognition	automatic
Self-Check	<i>Test:</i> Memory, optics, electronic measured value recording, barcode recognition, cell recognition <i>Automatic calibration:</i> Optics, electronic measured value recording, barcode recognition
Time/Date	Real-time clock in the photometer
Dimensions	H: 140 mm, D: 270 mm, W: 260 mm

Weight approx. 2.3 kg (battery version: 2.8 kg)

Meter safety EN 61010, IEC 1010

Safety class EN 61010-1/class 3

Power pack FRIWO FW 7555O/15
Friwo Part. No. 1822367

RiHuiDa RHD20W150100

Input: 100 ... 240 V ~ /
50 ... 60 Hz / 400 mA
Output: 15 V DC / 1 A

Power consumption in line operation max. 1300 mA

Batteries

- **Backup battery** 1 x 3,0 V Lithium battery, soldered in the instrument
- **Battery (optional)** Built-in battery: NiMH rechargeable battery 7.2 V/2500 mAh, operating time with new, fully charged battery: typical 40 hours with 10 measurements per hour, trickle charging in line operation, approx. 5 h charging time for a discharged battery, total discharge protection

EMC Directive 2004/108/EU
EN 61326-1
EN 61000-3-2
EN 61000-3-3
FCC class A

Climatic class 2, VDI/VDE 3540

Ambient temperature Storage: -25 °C to +65 °C
Operation: +5 °C to +40 °C

Allowable relative humidity Annual mean: 75 %
30 days/year: 95 %
other days: 85 %

Test certificate CE

15. Technical Data

Operating elements	<p>On/off switch actuated by opening/closing the lid of the cell shaft cover</p> <p>Silicon keyboard with 4 function keys</p> <p>Cell shaft</p> <ul style="list-style-type: none"> – for round cells (flat cell floor, external/internal diameter 16 mm / 13.8 mm) –
Display	Graphical display 128 x 64 pixels
Connections	
● Digital interface	RS 232 C 9-pin socket to connect to PC or printer
● Power supply	2-pin socket to connect the plug-in power supply unit
Data storage	Cyclical memory to record 500 measured values

Equipment Statement

Note: This equipment has been tested and found to comply with the limits for a Class A digital device, pursuant to Part 15 of the FCC Rules. These limits are designed to provide reasonable protection against harmful interference when the equipment is operated in a commercial environment. This equipment generates, uses, and can radiate radio frequency energy and, if not installed and used in accordance with the instruction manual, may cause harmful interference to radio communications. Operation of this equipment in a residential area is likely to cause harmful interference in which case the user will be required to correct the interference at his own expense.

Software settings when delivered

Measured value number:	1
blank value is:	Off
turbidity correct.:	Off
language:	English
Date of the last valid AQA1 check:	invalid (not yet measured)
AQA1 interval:	12 weeks
AQA2 interval:	4 weeks
AQA password:	0000
AQA mode:	Off
Lock measurement if AQA2 expired:	Off
Checks to be measured with AQA1:	none
AQA2 values:	none

Settings after reset - total

Measured value storage and setup reset

Settings after reset - meas. storage

Meas. value number:	1
Measured values:	none

Settings after reset - setup

Measured value number:	1
blank value:	Off
reference absorbance:	Off
turbidity correct.:	Off
Language:	unchanged

Settings after reset - AQA

Date of the last valid AQA1 check:	invalid (not yet measured)
AQA1 interval:	12 weeks
AQA2 interval:	4 weeks
AQA password:	0000
AQA mode:	Off
Lock measurement if AQA2 expired:	Off
Checks to be measured with AQA1:	none (Input theoretical values and tolerances are not erased and are offered again with the next input).
AQA2 values:	none (theoretical values and tolerances of all methods are set to default values according to the "Spectroquant® CombiCheck and standard solutions" table in the part "General information".)

16. What to do if...

The display remains blank when switched on	Connect the photometer to the line power via the power pack. In the case of battery operation: Battery empty, charging required (approx. 5h); line operation is possible without restrictions during charging time.
 appears	Battery nearly empty. Charging required (see chapter 3 COMMISSIONING).
Date/time is lost when switched off	The backup battery of the real time clock is empty and has to be replaced. Send the photometer to the service department for this.
Password forgotten	Inform the service department.
Photometer does not react	The connected printer is off line. Switch on the printer or pull out the interface cable.
Error messages:	
<i>remove cell</i>	The message remove cell appears on the display although no cell is inserted. Clean the cell shaft with a damp, lint-free cloth. If the error message still appears, return the photometer to the service department.
<i>lamp defective</i>	Replace the lamp (see chapter chapter 14 MAINTENANCE, CLEANING, DISPOSAL).
<i>no zero adjustment</i>	No zero adjustment is stored in the meter for the cell. Perform zero adjustment (see chapter chapter 11 ZERO ADJUSTMENT).
<i>method invalid</i>	No data is stored in the photometer for the selected method. Update method data (see chapter chapter 12 UPDATING METHOD DATA).
<i>wrong method</i>	During a difference measurement, the method was changed between the first and second measurement. During a difference measurement, the method must remain identical.
<i>E_0</i>	Hardware error: Send the photometer to the service department.
<i>E_1, E_2 or E_3</i>	Replace the lamp (see chapter chapter 14 MAINTENANCE, CLEANING, DISPOSAL). If the error message remains, send the meter to the service department.

What can Xylem do for you?

We're a global team unified in a common purpose: creating innovative solutions to meet our world's water needs. Developing new technologies that will improve the way water is used, conserved, and re-used in the future is central to our work. We move, treat, analyze, and return water to the environment, and we help people use water efficiently, in their homes, buildings, factories and farms. In more than 150 countries, we have strong, long-standing relationships with customers who know us for our powerful combination of leading product brands and applications expertise, backed by a legacy of innovation.

For more information on how Xylem can help you, go to xyleminc.com.



Service address:

Xylem Analytics Germany
Sales GmbH & Co. KG
WTW
Dr.-Karl-Slevogt-Str. 1
82362 Weilheim
Germany

Tel.: +49 881 183-325
Fax: +49 881 183-414
E-Mail wtw.rma@xyleminc.com
Internet: www.WTW.com



Xylem Analytics Germany GmbH
Dr.-Karl-Slevogt-Str. 1
82362 Weilheim
Germany