

Vapodest 20s

Programmable
Distillation System

Instruction Manual



Please read this instruction manual with care before you start operating the system!



Please observe the safety instructions of this manual marked with  in order to avoid any dangerous handling!



LAB Online Exhibition



Content

1 Important notes	4
1.1 How to use this instruction manual.....	4
1.2 Explanation of symbols.....	4
2 Safety.....	5
2.1 Operation as directed	5
2.2 Safety instructions	5
2.3. Work bench / Authorized user	6
2.4. Danger spots at the instrument	6
3 Technical description.....	7
3.1. Warranty conditions.....	7
3.2. Technical data.....	7
4 Description of the system.....	8
4.1 Front view Vapodest.....	8
4.1.1. Description to front view	9
4.2 Rear view Vapodest.....	10
4.2.1. Description to rear view	11
5 Assembly and installation	12
5.1. Check for transport damage.....	12
5.2. Unpack apparatus and set up.....	12
5.3. Package list	13
5.4. Tubing connections.....	14
5.5. Mains connection Vapodest.....	15
5.6. Turn on apparatus	16
6 Control panel and main menus	17
6.1. Control panel Vapodest	17
6.2. Main menus Vapodest.....	18
7 System settings	19
7.1. Select language.....	19
7.2. Setting contrast.....	20
7.3. Reagents	21
7.3.1. Set level sensor for tank.....	21
7.3.2. Calibrate dosing pumps.....	21
7.4. Service (Statistic).....	23
8 Create a method (Programming).....	24
8.1. Define a new method.....	24
9 Execution of method.....	27
9.1. Prior to the analysis	27
9.2. Distilling a sample.....	27
9.3. Interrupt distillation	29
10 Trouble shooting	30
10.1. Error messages	30
10.2. Results too high.....	31
10.3. Results too low or no results	31
10.4. Breakdown of operation.....	32
10.5. Maßnahmen bei überflutetem Verteilerkopf.....	32

Content

11 Instandhaltung	32
11.1. Cleaning and regularly check	33
11.1.1. Cleaning general.....	33
11.1.2. Cleaning program	33
11.1.3. Check the tight fitting of the tubes	33
11.2 Tubing diagram Vap 20 s (with open rear wall).....	34
11.2.1. Description of the tubing diagram	35
11.3. Spare parts	36
11.4. Accessories.....	37
12 Decommissioning and disposal.....	38
12.1. Decommission	38
12.2. Contact service	38
12.3. Disposal.....	39
12.3.1. Information for the Disposal of Electric and Electronic Instruments within the European Union.....	39
12.3.2. Ban on Materials according to ROHS Regulation 2002/95/EG	39
12.3.3. Transfer	39

1 Important notes



1.1 How to use this instruction manual

Please make sure that the persons working with the Vapodest have read and understood this manual in order to observe all the instructions.

This instruction manual must be accessible to all users at any time and is a part of the Vapodest system!

The instrument will be called "Vapodest 20s" in the entire document.

This instruction manual only explains the technical details necessary for the operation of the instrument but is NOT a complete technical description.

The security advises given in this manual have to be observed under all circumstances! The symbols at the border of the text emphasize the dangers cited in the text.

Symbols at the instrument warn of possible dangers and will refer you to this manual!

The copy right of this manual remains with C.Gerhardt GmbH & Co. KG

Reproduction and copying are only allowed with the permission of C.Gerhardt GmbH & Co. KG

1.2 Explanation of symbols

	Attention! Advance notice of danger spots, carefully read instruction manual!
---	--

	Attention! Read instruction manual!
---	--

	Attention! Hot surface!
---	----------------------------

	Attention! Use eye protection!
---	-----------------------------------

	Attention! Mains voltage!
---	------------------------------

	Attention! Use protective gloves!
---	--------------------------------------

	Attention! Beware of hot liquids and vapours!
---	--

	Notice! Important information!
---	-----------------------------------

	Attention! Advance notice of substances which might be a health risk or cause irritation!
---	--

2 Safety

2.1 Operation as directed

With the Vapodest 20s you have purchased an automatic distillation system with automatic addition of NaOH for the steam distillation of Kjeldahl digestions and associated distillations.



Make sure to use the instrument according to our instructions, especially:

- all instructions of this manual
- the regulations in place in the country the instrument is used

All other usage is not recommended!



C. Gerhardt GmbH & Co. KG is not liable for any damages caused due to non recommended usage

- no modifications are allowed for safety reasons
- repairs of electric, electronic or mechanical components may only be done by authorized personnel!

2.2 Safety instructions



The Vapodest 20s corresponds to the technical standard used at this date and observes the safety rules and regulations in place.

It is understood that the user has to observe

- the accident prevention regulations in place
- the general accident prevention regulations
- EU-regulations or other country specific instructions



Indicating label and danger symbols must not be taken off!



Alle engineered safeguards must not be taken out of operation!



Make sure that no liquid gets into contact with cable connections or the interior of the electrical parts of the unit!

- Danger of electric shock!



In case of an emergency disconnect from mains immediately!



Always pull the mains plug before opening!

- Danger of electric shock!



Prior to each start, make sure that the protection door is closed tightly.
Danger of burns and splashing liquids!



Make sure to wear protective gloves when taking the digestion tubes out and wear protective glasses as well.

The digestion tubes are very hot and there is the danger of burns!



Attention when handling chemicals! Please observe the manufactures safety instructions (see label) and your national safety regulations!

2 Safety



2.3. Work bench / Authorized user

The Vapodest 20s must not be run in damp or hazardous location. The maximum humidity allowed is 80 %, the maximum room temperature must not exceed 35 °C!



The equipment must not be exposed to aggressive vapors of acids, alkalis, or solvents.



The Vapodest 20s has to be placed on a horizontal and stable footprint.



The Vapodest 20s may only be operated by trained staff or specially trained persons.

The user has to:

- read, comprehend, and observe the operation manual
- wear suitable clothes for laboratory work
- deny access to any unauthorized personnel

2.4. Danger spots at the instrument



- Attention, danger of burns on the surface of the digestion tubes!



- Attention, danger of splashing hot or caustic liquids at the tubing connections at the back of the instrument!



- Attention, danger of burns when taking out the hot glass container!
Use gloves when removing the glass digestion tubes!

3 Technical description

3.1. Warranty conditions

Vapodest 20s carousel is designed and fabricated following the high quality guidelines of DIN EN ISO 9001.

On the basis of the C. Gerhardt conditions of warranty our products are guaranteed for 1 year as long as the equipment is used according to the instructions in this manual. Also fill out the "Report for the installation and initial operation" and send back to C. Gerhardt.

Please note that the following parts are excluded from warranty.

- Digestion tube, Order-no.: 12-0301
- Vitone cone, Order-no.: 12-0351

3.2. Technical data

Nominal voltage: 230 V AC, 50 Hz or 115 V 60 Hz or 230 V 60 Hz

Nominal wattage: 1600 W

Cooling water consumption:
about 5 liters per distillation minute

Cooling water pressure:
min. 0,5 bar, max. 6 bar

Pump capacity (read chapter 7.3.2. Calibrate dosing pumps)

- Diaphragm pump about 15 ml/s with water
about 10 ml/s with NaOH
- Peristaltic pump about 10 ml/s with water

Storage tanks: any size, recommended:
Set of storage tanks KAN 20

Display: LED with illumination

Programs: 10

Dimensions: 440 x 690 x 340 mm W x H x D)

Weight: 25 kg

Interface:
- Vapodest 2 x RS 485 interface: Connection for GerBus®
1 x 5-pin connector for level sensor storage tanks

4 Description of the system

4.1 Front view Vapodest

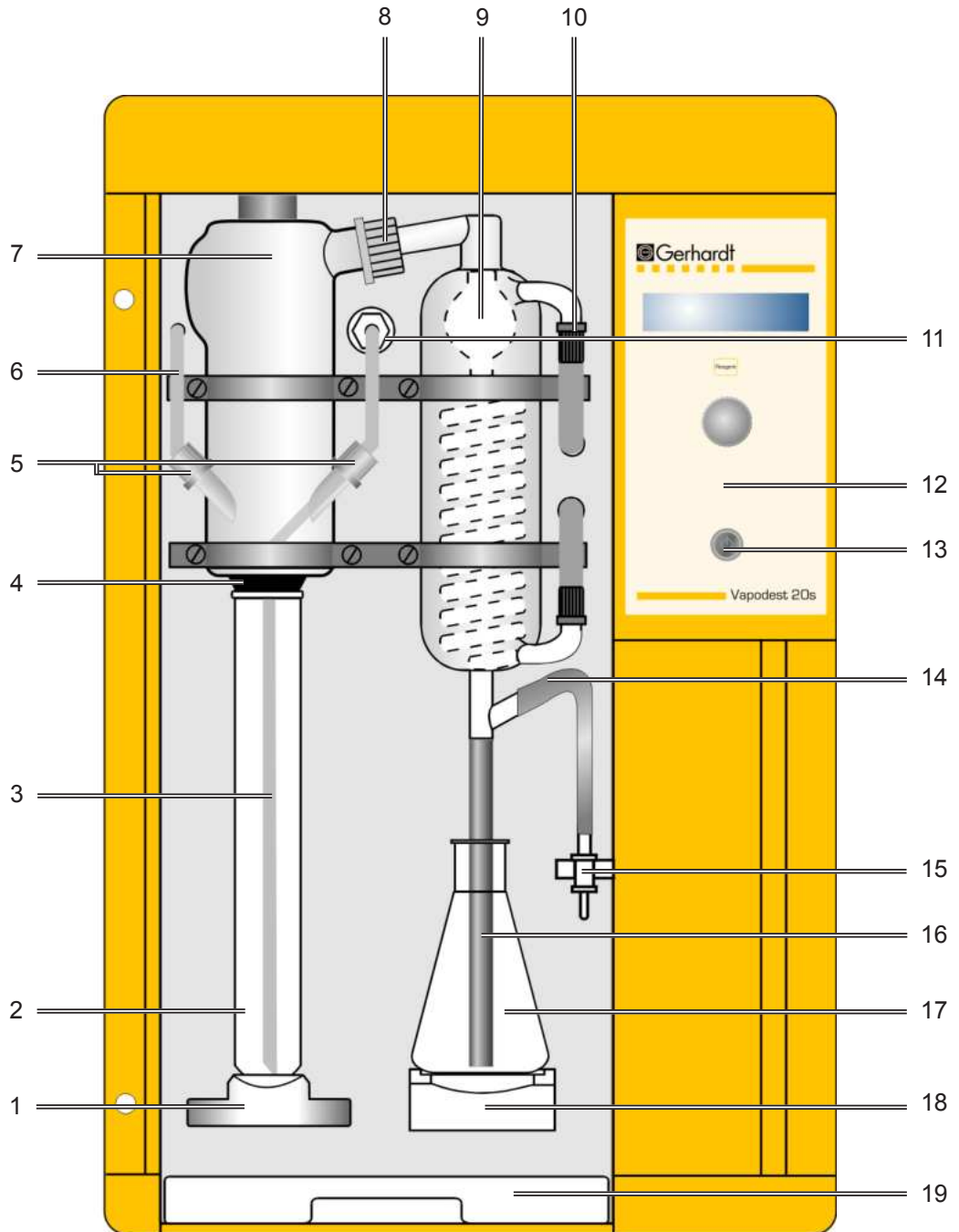

4 Description of the system

4.1.1. Description to front view

- 1 Quick clamping device with wedge, Item-No. 1000537**
Press down the quickclamping device in order to insert digestion tube.
- 2 Kjeldatherm-digestion tube, Item-No. 12-0301**
Special glass with cut. 100/250 ml or flask with enlarged neck 250/500/750 ml or KDD 400/800 ml or BS 400 ml.
- 3 PTFE-inlet tubing steam, Item-No. 1002178**
Steam, water for dilution, and the suction of the sample residues passes through here. Please check regularly that the opening of the PTFE-tube is not blocked by crystallisation.
- 4 Viton cone, Item-No. 12-0351**
Macro for 250 ml tubes
- 5 Screw cap GL 18, Item-No. 1004321**
with silicone/PTFE seal
- 6 PTFE-inlet tubing, NaOH, Item-No. 1003401**
Sodium hydroxide solution enters here.
- 7 Distribution head glass, Item-No. 12-0363**
Distribution head prevents that any sample residue gets into the receiver.
- 8 Screw cap GL 32, Item-No. 1004322**
with silicone/PTFE seal
- 9 Distillation condenser, Item-No. 1000058**
Combined ball- and coil condenser with high cooling power.
- 10 Screw cap GL 14, Item-No. 1004320**
with plastic screw connection
- 11 PP-Distributor with PP-threaded joint, Item-No. 1000538**

- 12 Control panel Vapodest**
See chapter 6.1. Control panel Vapodest".
- 13 Mains switch**
Turn instrument on or off
- 14 Tube for ventilation valve, Item-No. 1000484**
Connection to ventilation valve.
- 15 Ventilation valve, Item-No. 1000036**
During and after distillation the ventilation valve prevents suck back of the receiver solution into the condenser.
- 16 Distillate outlet tubing, Silicone 8/12, Item-No. 1000496**

- 17 Erlenmeyerflask (not included in delivery)**

- 18 Platform - Item-No. 1001871**

- 19 Drip tray, Item-No. 1000399**
Condensate which might drip is collected in the drip tray.

- ** Protection door (not illustrated) - Item-No. 1001263**
Whenever you run the distillation system make sure you shut the protection door!

4 Description of the system

4.2 Rear view Vapodest

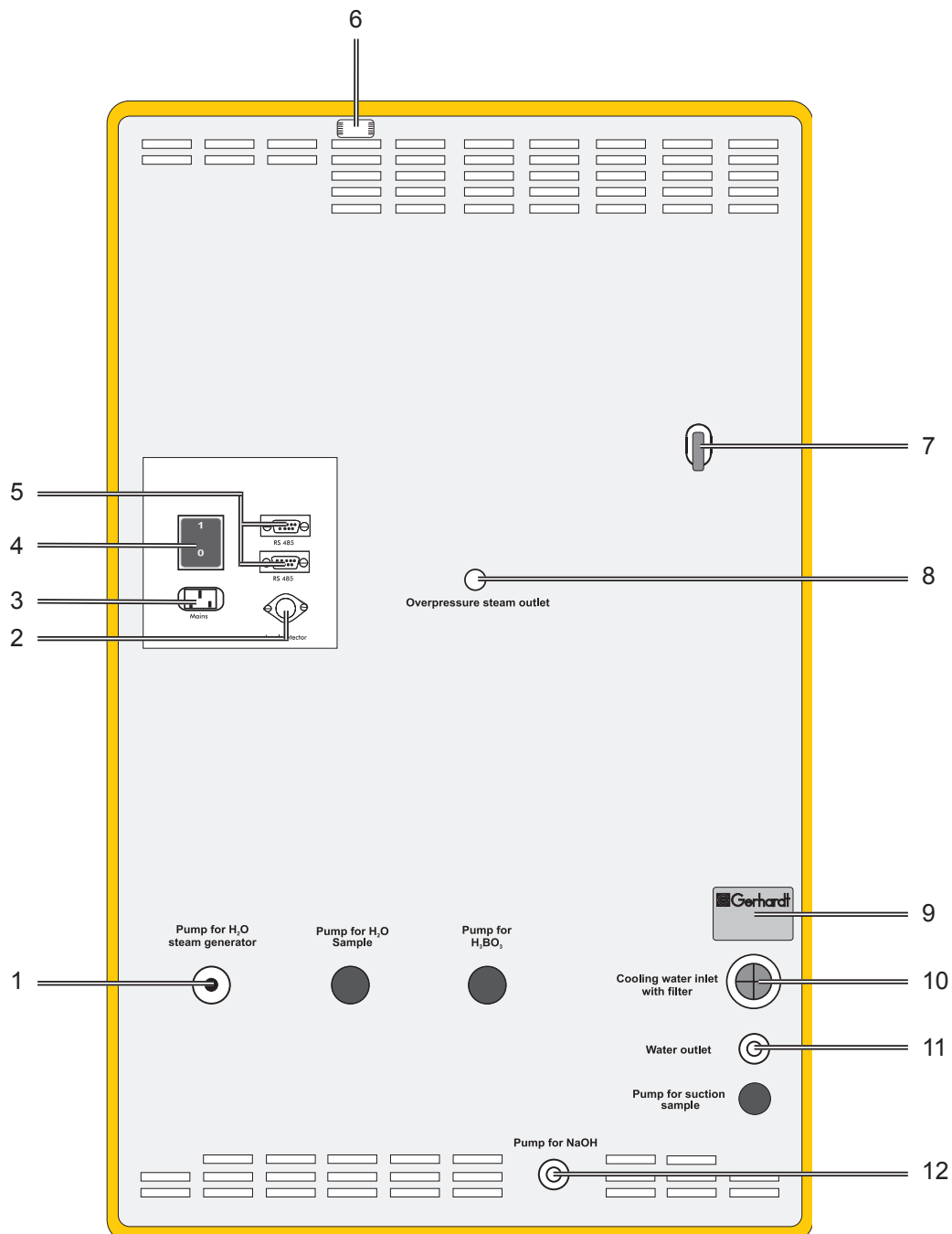

4 Description of the system

4.2.1. Description to rear view

- 1 Diaphragm pump for H₂O steam generator, Item-No. 1001736**
Connection pipe for PVC-tubing 4/7, connection to the storage tank "H₂O".
- 2 Level detector**
Connector for diode plug, 3-pin (level detector for set of storage tanks)
- 3 Appliance plug for mains cable**
The enclosed mains cable is plugged in here
- 4 Excess current switch, 10A,**
Equipment is cut off automatically if there is excess current
- 5 2 x Interface RS 485**
-  **6 Outlet ventilation tubing (protected)**
Ventilation for steam generator, here hot steam can escape
- 7 Excess pressure - steam outlet**
Safety device to let steam escape in case of overpressure in the boiler..
- 8 Excess temperature fuse,**
Safety measurement to turn off heating if the water level in the steam generator drops so low that the heating cartridge is not covered any more. See also error message in chapter 10.
- 9 Identification plate with serial number of the instrument**
Please make sure to always refer to the serial number in any case of service problem.
- 10 Cooling water inlet with sieve, Item-No. 1000363**
Anschlussgewinde 3/4 Zoll für Wasserzulaufschlauch 10/17.
- 11 Water outlet**
Connection pipe for PVC-tubing 8/12, connection to water outlet
- 12 Diaphragm pump for NaOH, Item-No. 1001738**
Connection pipe for PVC-tubing 8/12, connection to storage tank "NaOH"

5 Assembly and installation

5.1. Check for transport damage

Before assembling the apparatus please check if the content of the box is complete and intact!

In case of any damage, please notify your carrier (post, rail, road) as well as your supplier!



5.2. Unpack apparatus and set up

The VAPODEST must not be run in damp or hazardous location. The maximum humidity allowed is 80 %, the maximum room temperature must not exceed 40 °C!

There should be sufficient space for the set of tanks below the work bench.. Make sure, however, that those tanks are not higher than the Vapodest!

You need a connection (cold water pipe) with 1/2 inch thread to connect it to the water supply.

Make sure to take a faucet, which can be connected to the inlet tubing permanently. The water pressure must be at least 0,5 bar in order to activate the integrated pressure detector.

Please observe the local water and waste regulations and those of your public water supply company! Please note that the length of the inlet and outlet tubing is restricted to 2 metres.

The VAPODEST 20s distillation system comes fully pre-assembled. Please unpack the equipment with care !

1. Place the equipment on a stable work bench.
2. Unpack accessories

The exact contents of the delivery can be checked by the following list.

5 Assembly and installation

5.3. Package list

- 1 x Distillation system Vapodest 20s,
complete mounted
- 1 x Digestion tube 250 ml, Item-No. 12-0301
- 1 x Water inlet tube 10/17 mm with connections of 1/2 inch and 3/4 inch, 2m
Item-No. 1000394
- 1 x PVC-tubing 4/7, 2 m, Item-No. 1000500
- 2 x PVC-tubing 8/12, 2 m, Item-No. 1000497
- 1 x PVC-pipe 6x1, 400 mm, Item-No. 1000566
- 1 x PVC-pipe 10x1, 400 mm, Item-No. 1000567
- 1 x Mains cable, Item-No. 10-0057
- 1 x Instruction manual
- 1 x Test report
- 1 x Installation report

5 Assembly and installation

5.4. Tubing connections

When establishing the tubing connections, make sure to observe the labeling of the connection at the rear of the instrument.

Set up store tanks for distilled water and sodium hydroxide solution under the work bench

Fig. 5.4.a Tubing diagram (with set of storage tanks KAN 20, optional)

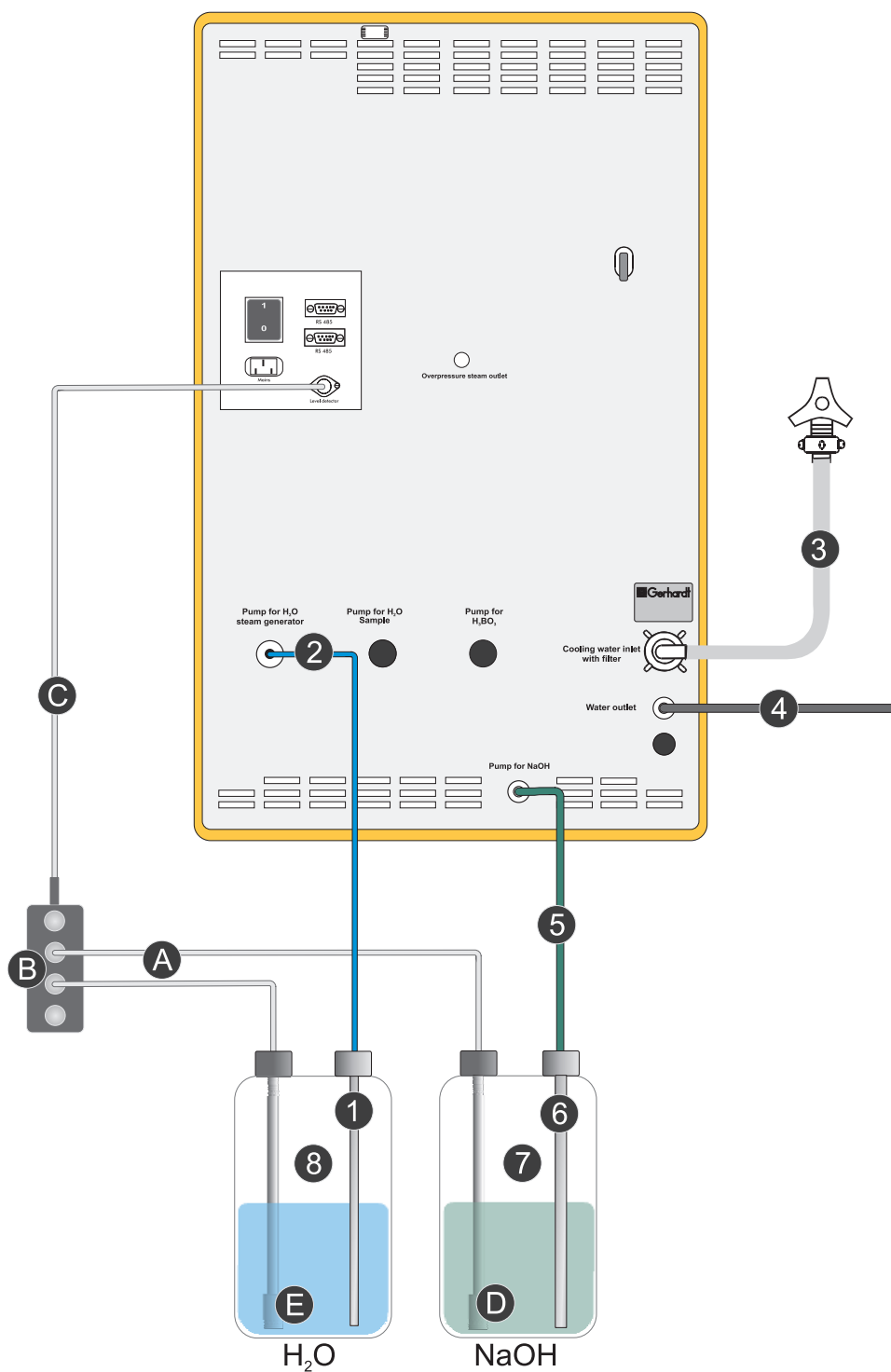

5 Assembly and installation

Description to tubing connections (Fig 5.4.a)

- 1 PVC-pipe 6 x 1 mm, 400 mm long
- 2 PVC-tubing 4/7, 2 m, inlet H₂O steam generator
- 3 Cooling water inlet tubing 10/17, 2 m long
- 4 PVC-outlet tubing 8/12, 2 m, for cooling water (place into a drain)
- 5 PVC-tubing 8/12, 2 m inlet NaOH (Reagent)
- 6 PVC-pipe 10 x 1 mm, 400 mm long
- 7 Storage tank 20 l, for NaOH (Reagent)
- 8 Storage tank 20 l, for H₂O

Connection of set of storage tank KAN 20

- A 2 x connection cable from level detection tank to distribution box
- B Distribution box with 4 plugs
Blank off the remaining diode socket of the distribution box with the dummy diode plug enclosed.
- C Connection cable from distribution box to socket level detection Vapodest
- D Level sensor with plug for sample waste tank, complete
- E Level sensor with plug for chemicals tank, complete

Fill tanks with chemicals:



- H₂O distilled or demineralized
- e.g. NaOH 32%

5.5. Mains connection Vapodest



Please check the nominal voltage on the product information plate before connecting to the mains. Should the nominal voltage deviate for more than +/- 10%, then you must contact your service engineer.

- Connect the mains cable with the rear appliance plug and the shockproof socket
- Check if excess current release at the rear (chapter 4.2, pos. 4) of the equipment is in position „1“. This switch turns the equipment off when it takes too much current.

5 Assembly and installation



5.6. Turn on apparatus

Always close the protection door before operating the distillation unit!

1. Turn on tap completely.
2. Start Vapodest by turning the mains switch on.

The display shows the number of the current software version and the actual status.

```
Vapodest 20s  
C. Gerhardt
```

```
Vapodest 20s  
Version X.X
```

```
Vapodest 20s  
Heating
```



In order to run an analysis you have to wait for about 5 minutes till the steam generator has reached its operating pressure. All other functions are available right away.

3. After the system is ready, the display shows the following message:

```
Vapodest 20s  
Standby
```

4. Now you can enter further system settings or start an already entered program. Make sure to read the next chapter!

6 Control panel and main menus

6.1. Control panel Vapodest

Fig. 6.1:
Control panel
Vapodest 20s

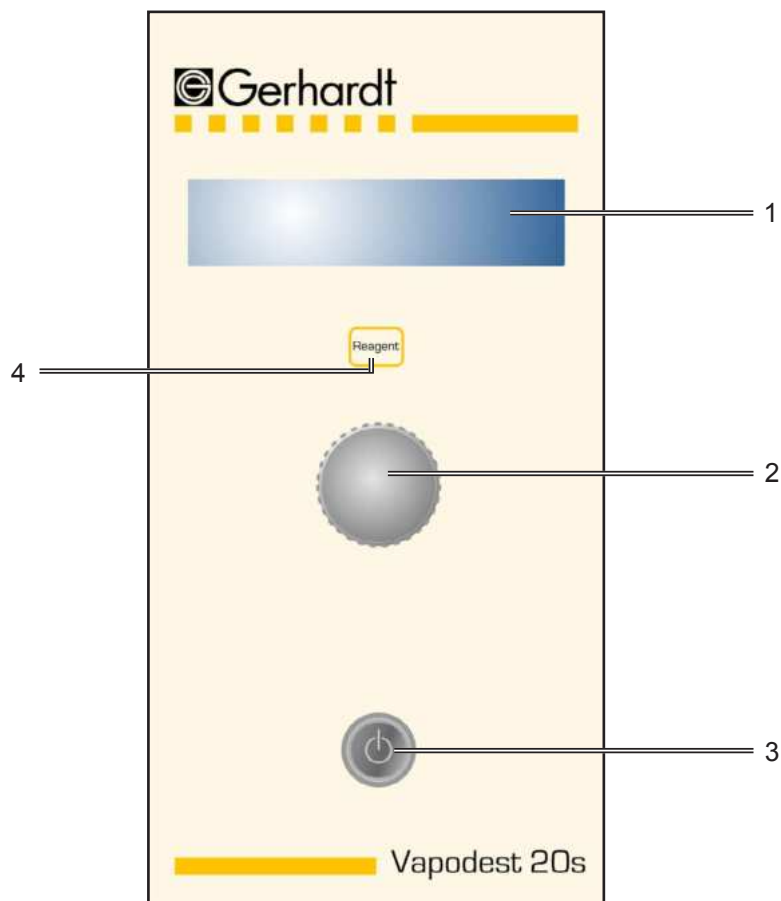

1. Display

Shows the current status of the instrument

2. Operator button



Turn the operator button =
select menu or increase
respectively lower the amount



Press the operator button =
confirm selection



**Keep the push button pressed
and turn it back in counter
clockwise direction =**
back to main menu (exit function)



3. Mains switch

Turn instrument on or off

4. Key "Reagent"

Manual addition Reagent (NaOH)

6 Control panel and main menus

6.2. Main menus Vapodest

From the initial menu you get to the main menus by turning the multi functional push button.

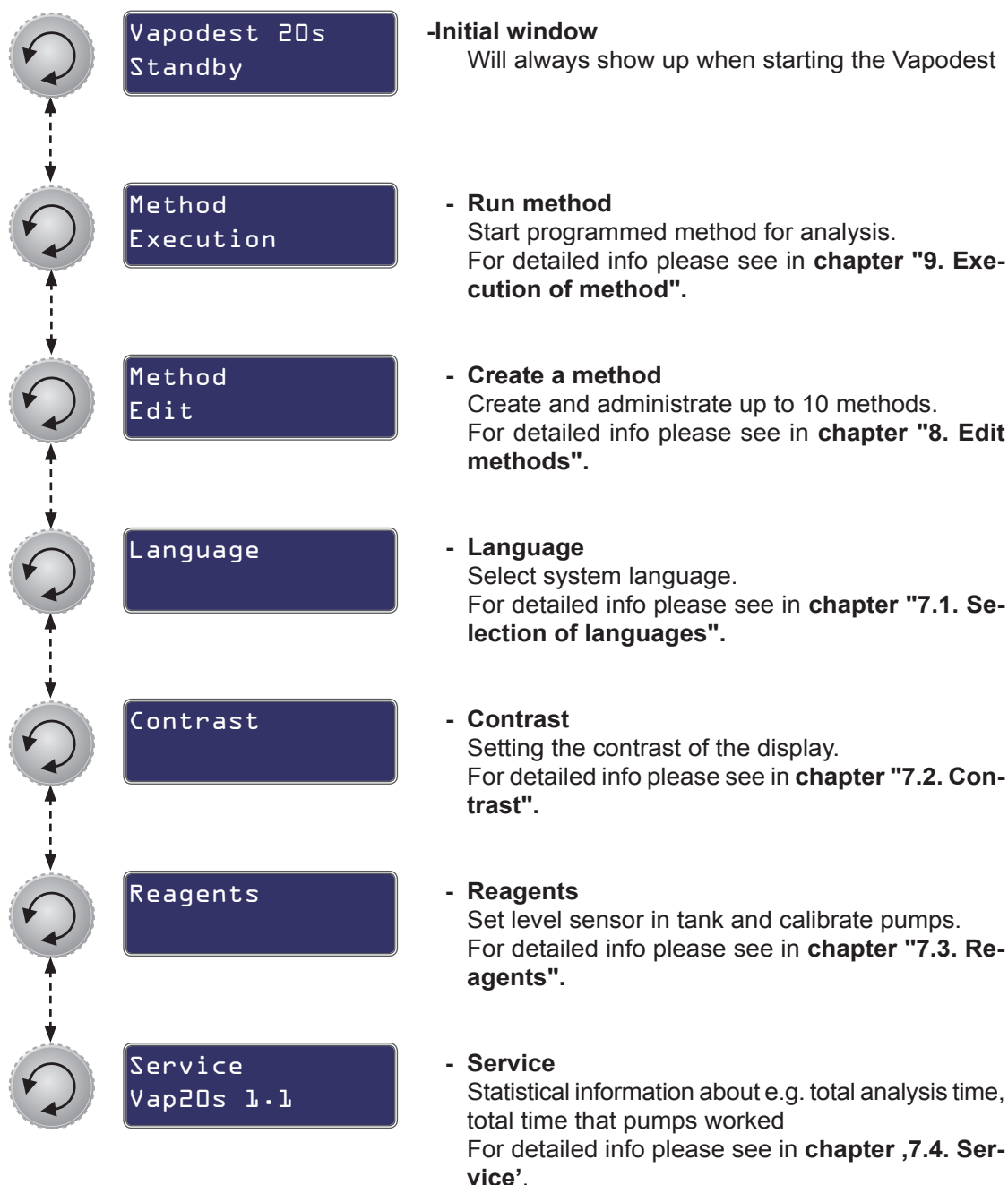

7 System settings

In this chapter the basic functions for Vapodest are explained. For standard procedures it is sufficient to determine these functions once when the instrument is taken into use for the first time.

7.1. Select language

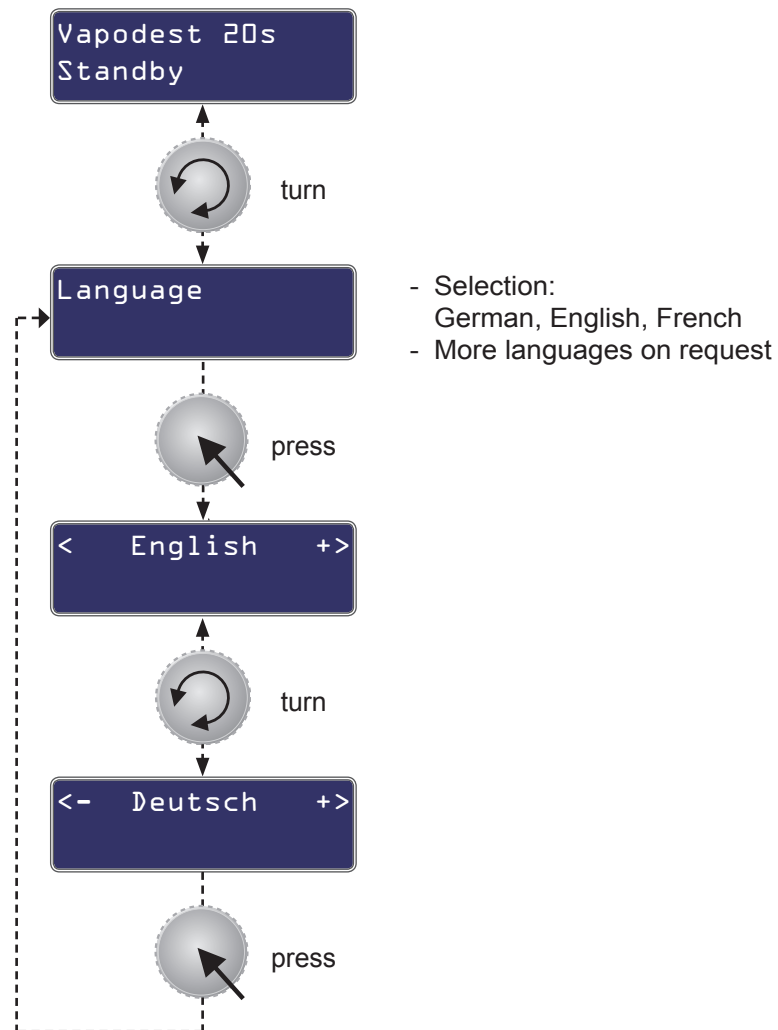

7 System settings

7.2. Setting contrast

From the initial window, there are 2 options to set the contrast.

1. Option
Via main menu

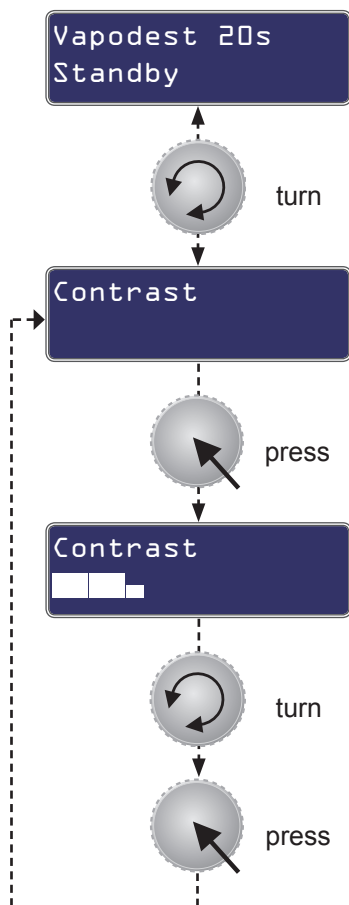

2. Option
Using the combination of keys

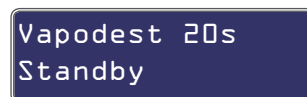

Multifunctional push button. Turn it while keeping it pressed down.

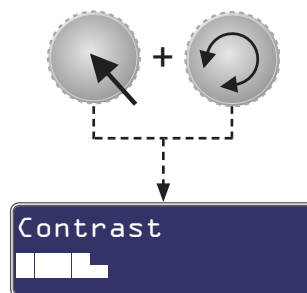

7 System settings

7.3. Reagents

Menu for setting the level control in the tank and calibrating the pumps. The delivery rate of the pump depends on the viscosity of the chemicals used, the delivery height and further other conditions. Thus, you must calibrate the dosing pumps prior to the first operation or whenever the chemicals used are changed.

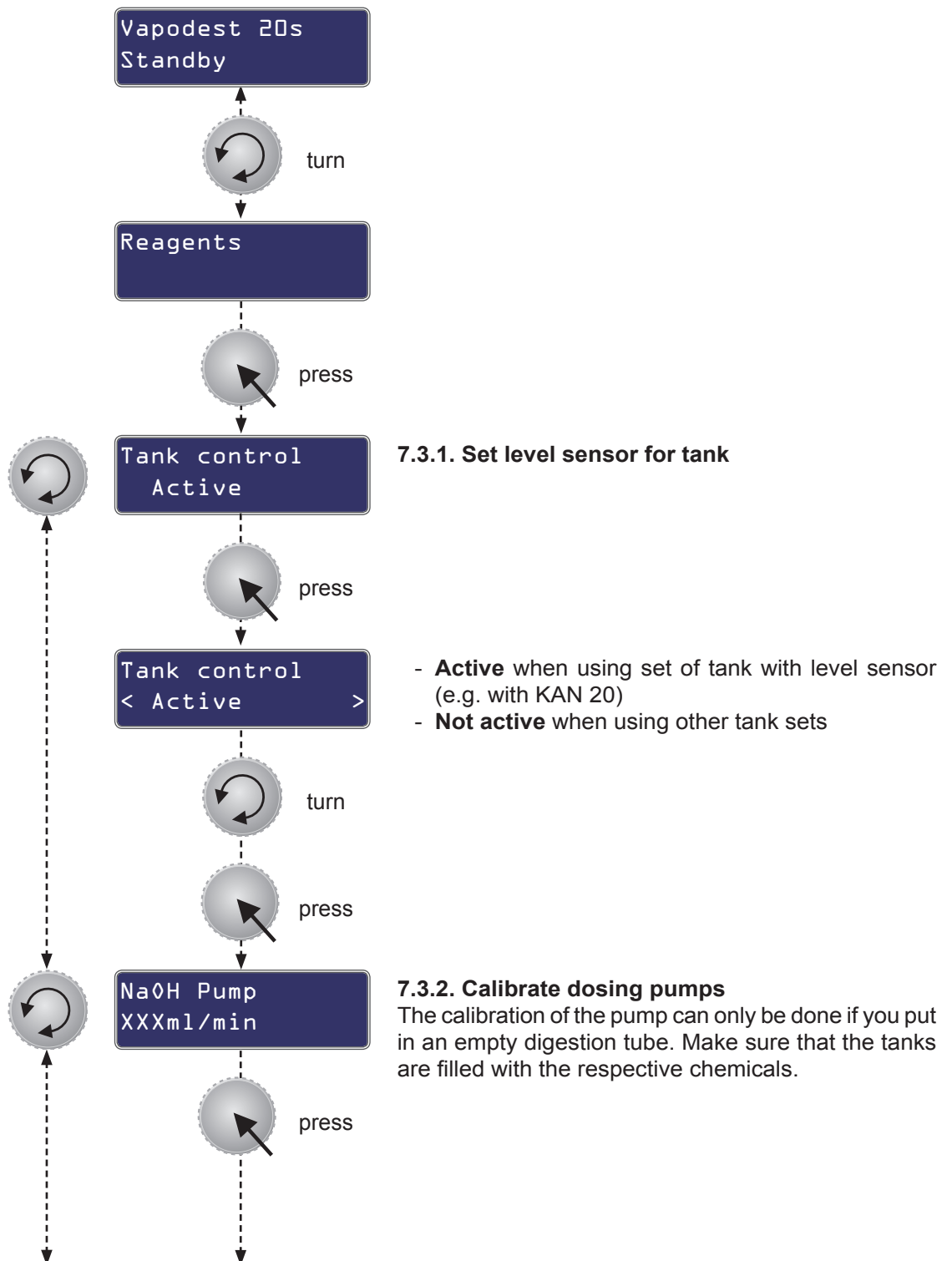

7 System settings

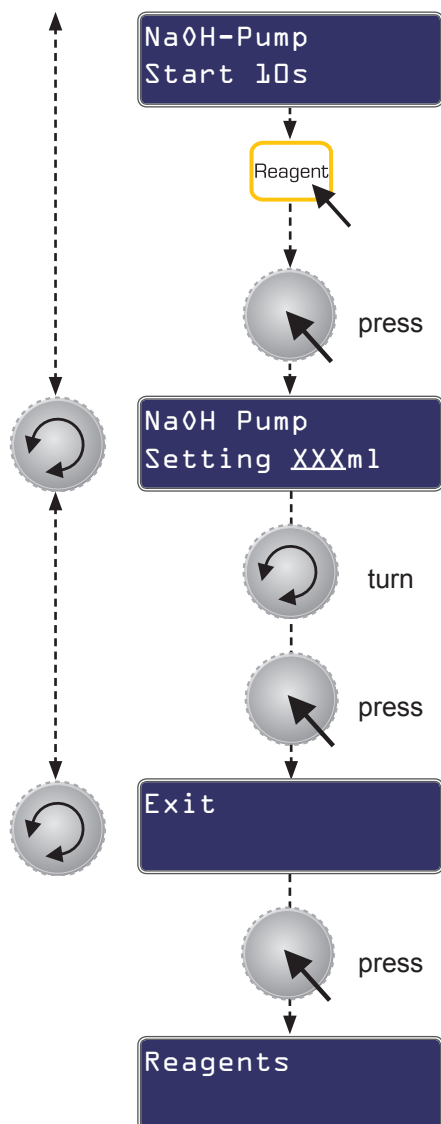

1. Push quick clamping device down and put in **empty digestion tube**.
2. Aerate tubings
Press Vapodest-key **Reagent** (NaOH) till liquid accumulates in the digestion tube.
3. Empty digestion tube and then put it in again.
4. Press operator button to start the process.

Determine the delivery volume

After 10 seconds of the transport time, take out digestion tube and fill content into a measuring flask.

Turn multi functional button to enter the volume.

Comment, the volume entered is calculated to ml/min.

5. Determine the delivery volume
After 10 seconds of the transport time, take out digestion tube and fill content into a measuring flask.
Turn multi functional button to enter the volume.
Comment, the volume entered is calculated to ml/min.

7 System settings

7.4. Service (Statistic)

Menu to call up statistical data, like e.g. total running period, run-time of pumps, etc

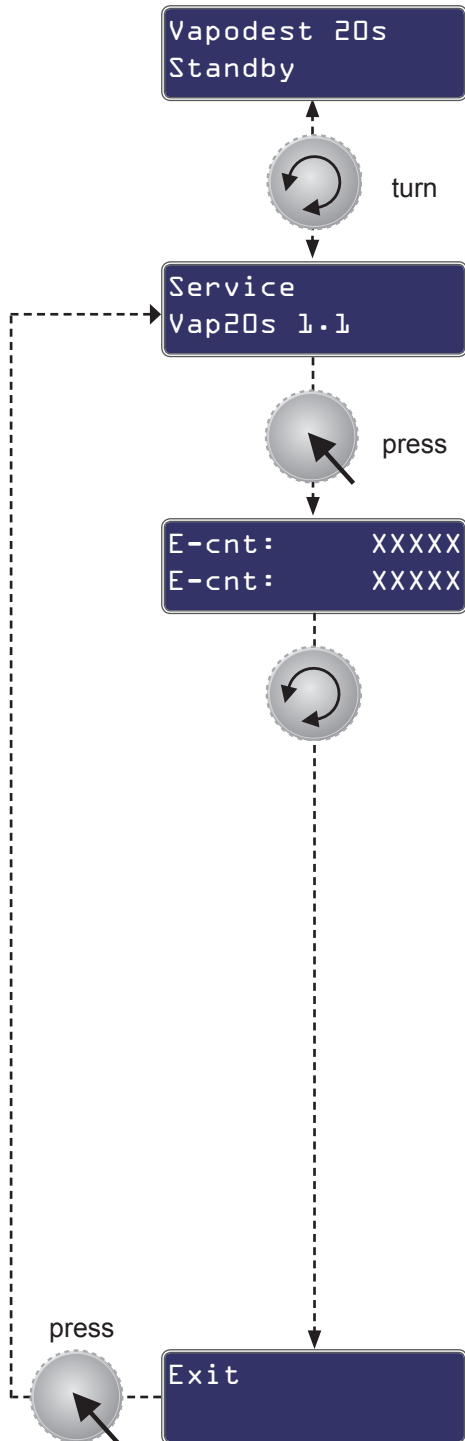

E-cnt: = Start-up counter since initial operation
E-cnt: = Start-up counter since last service

By turning the push button you can obtain further data.

D-cnt = Number of distillations since initial operation
D-cnt = Number of distillations since last service

O-tot = Total running time of distillation system since initial operation
O-act = Total running time of distillation system since last service

H-tot = Total running time of H₂O-pump since initial operation
H-act = Total running time of H₂O-pump since last service

N-tot = Total running time of NaOH-pump since initial operation
N-act = Total running time of NaOH-pump since last service

8 Create a method (Programming)

In this chapter "Create a method", all relevant parameter for the control of the analysis are explained. Up to 10 programs can be defined. Program 00 is a defined test program.

8.1. Define a new method

Vapodest 20s
Standby



turn

Method
Edit



press

M01 -
Selection

1. Selection of program M00 up to M19



turn



press

M01 -
Edit name

2. Enter or edit programname here
(max. 12-place)



press

M01 Ammoniu_----
Edit name

Turn the push button till the desired character is shown. The following characters are available:

ABCDEFGHIJKLMNOPQRSTUVWXYZ
1234567890-+&@=_!%\$><#



turn



press

Then, press the button so that the cursor gets to the next available space. Now, you can enter an additional character or terminate the name assignment by pressing the button again.

8 Create a method (Programming)

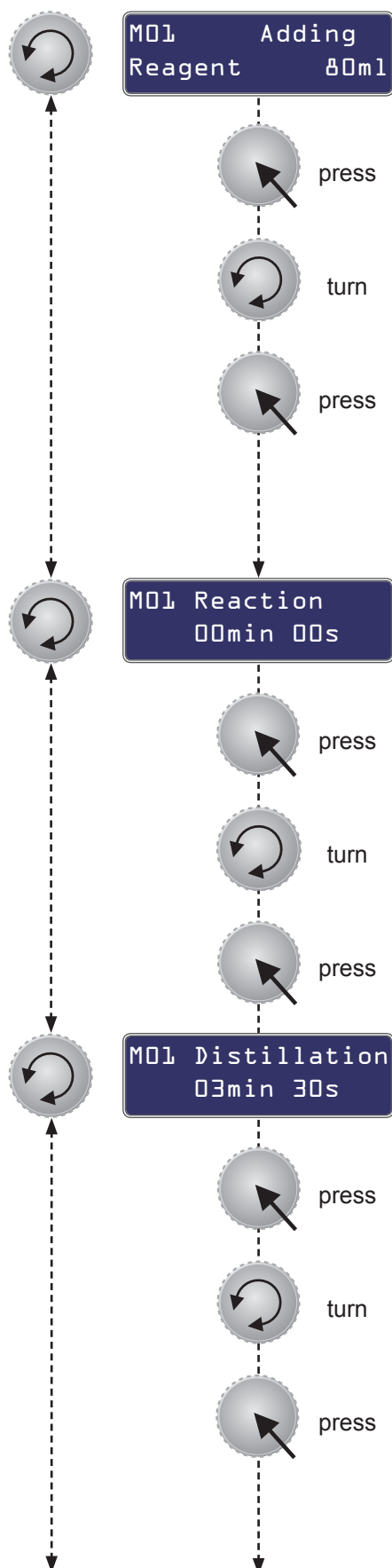

3. Addition NaOH

In order to be able to distil ammonia over it is important to create a strong alkaline environment. When catalysts containing copper sulphate are used, a colour change of the sample takes place if it is alkaline. When Selen is used as a catalyst, an indicator can be added to the sample to have a visual check. The addition of NaOH depends on the amount of free (unbound) sulphuric acid at the end of the digestion.

In general, the quadruple amount is needed for a 32% NaOH.

- Setting range 0 - 200 ml
(the specification of the dosing steps depends on the calibration of the pumps).

4. Reaction time

The reaction time is especially for the nitrate nitrogen determination when Devarda's alloy is used (e.g. for the analysis of fertilizers). For Kjeldahl analysis this amount of time is not necessary.

- Setting range 0 - 99 min and 0 - 59 s

5. Distillation time

The distillation has to be set so that about 100ml distillate is produced. If the steam output is set to maximum this corresponds to 3 min 30 s to 4 min. In the water analysis, a phosphate buffer is used instead of NaOH for the determination of the ammonium-nitrogen. In such a case, 200 ml have to be distilled over.

- Setting range 99 min and 59 s

8 Create a method (Programming)

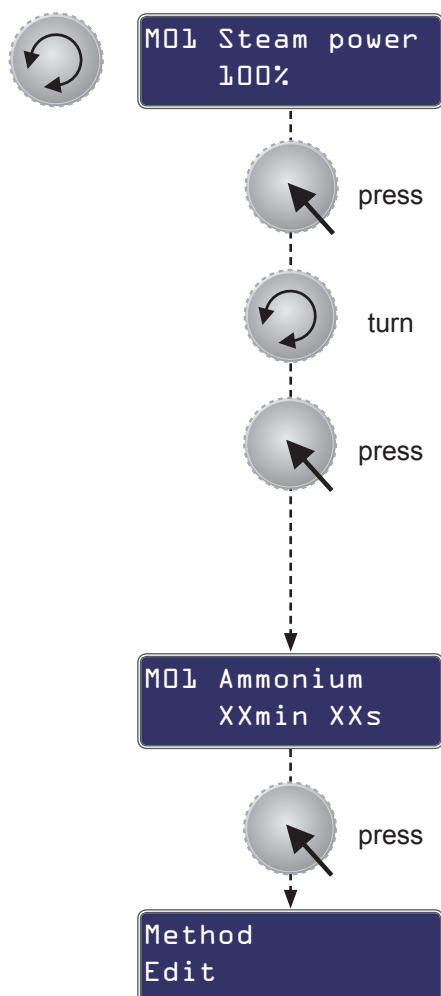

6. Steam power

Usually, maximum power is used for the Kjeldahl analysis. If the power is reduced, the distillation time is increased at the same time to obtain the same amount of distillate. For some determinations, e.g. for the determination of ammonium, a certain amount of distillate is required for a given amount of time.

Attention, when micro glasses with 100 ml are used, the max. heating power should be 80 %.

- Setting range 30 % - 100 %

7. Total time

Display shows the total time for this program.

9 Execution of method

This chapter describes the execution of a distillation. However, we can only give you a general overview how to work with Vapodest in this manual. Should you need any specific methods we will send you the respective application on request. These data sheets contain detailed info about the sample preparation and programming.



Make sure to always wear protective clothes (gloves, protective glasses, lab coat) when working with Vapodest.



When you take out the digestion tube, make sure to wear protective glove or have glass tongs at hand and wear protective glasses. The glass container is very hot and there is the danger of burns!



Be careful when handling acids and alkalis! Please observe the safety regulations according to the current laws regarding handling of dangerous goods!

9.1. Prior to the analysis

Check set of tanks

Check the level of reservoirs and the connections at regular intervals.

Turn on faucet

The system is only working when the faucet is turned on.

Test run

In order to make sure to obtain reproducible results, we kindly ask you to run a distillation without sample every day prior to the first analysis. In order to do so, insert the digestion tube and start **Program M00 Test**.

9.2. Distilling a sample

1. Press down quick clamping device and insert the digestion tube.
2. Check correct fit of the tube.
3. Close protection door and turn on equipment.

Vapodest 20s
Standby



turn

Method
Execution



press

4. The display shows the standby mode

9 Execution of method

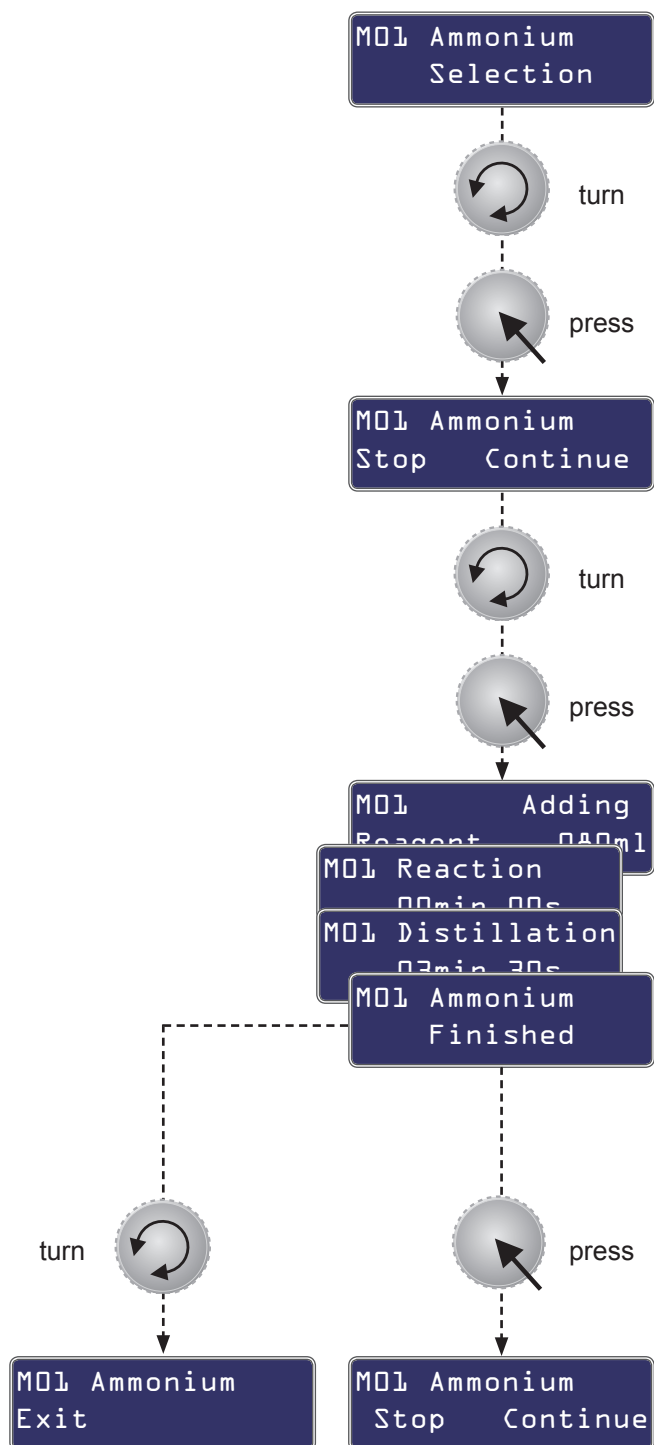

5. Program number is flashing.

Select the method program as desired (M00 to M09).

6. Continue = the program starts immediately Stop = back to main menu

Current selection is flashing

In the display, the individual program steps are shown. The program can be interrupted at any time during the distillation in progress. Please see chapter "9.3. Interrupt distillation".

7. At the end of the program, take out the digestion tube. In order to do so, push the quick clamping device downwards.

Careful! At the end of the distillation, the digestion tube is very hot. Thus make sure to wear protective gloves and protective goggles!!

8. Would you like to continue with the program and run additional analysis, then please insert a new digestion tube and press the push button.

Should you not wish any additional analysis, then turn the push button in any direction and select "Exit".

9 Execution of method

9.3. Interrupt distillation

The distillation program in process can be interrupted at any time.

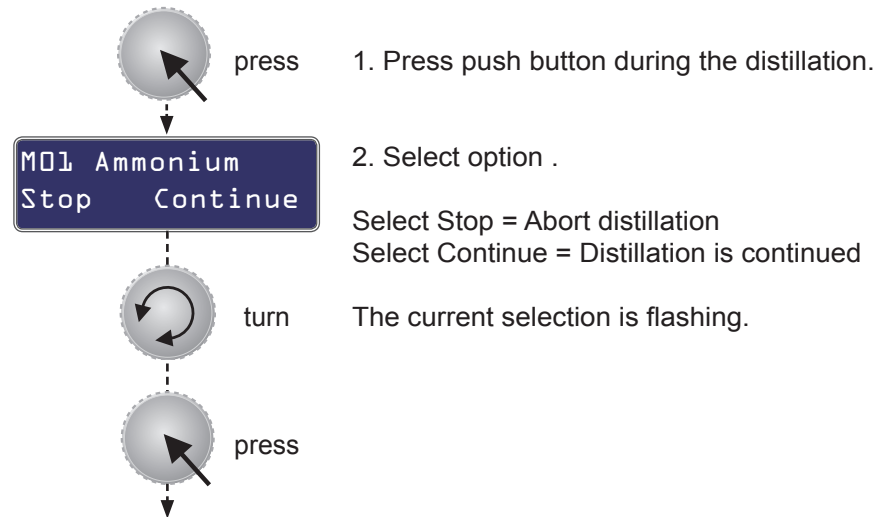

10 Trouble shooting

The functions of the distillation system are monitored continuously. As soon as an error occurs, it is shown in the Vapodest-display, After solving the error you can continue the analysis in most cases. The user might have to confirm a corresponding message in the display

10.1. Error messages

Error message	Reason for error	Actions to be taken
Water pressure low	Cooling water pressure < 0,5 bar.	Check cooling water inlet. Make sure that the faucet is turned on.
Tube or door Error	No sample tube or door open	Insert digestion tube and / or close protection door.. Distillations can only be done if the digestion tube is inserted correctly and the protection door is closed.
Wait for steam	Steam generator has not yet reached its required pressure	Message disappears, as soon as the steam generator has reached the correct pressure.
Method Not defined	The selected program has not yet been defined	Define method program or select a different method
Tank level Error	One or more storage tanks are empty or sample waste tank is full.	<ul style="list-style-type: none"> - Check content of storage tanks and if necessary, fill it up. - Also, check contacts for level sensor - The distillation in process will be completed.
Steam generator Low water	Not enough water in the steam generator, water inlet might be broken	<p>Check tubing connection from water tank to Vapodest</p> <p>Should the problem reoccur, call customer service.</p>
Steam generator Sensor Error	Water level of steam generator is not measured any longer.	Turn instrument off, and then turn it on again. Should the problem reoccur, call customer service.
Steam generator Excess pressure	Water level in steam generator too low. Heating starts too early.	Turn off instrument for ca. 15 min and turn on again. Should the problem not be solved, call customer service.

10 Trouble shooting

10.2. Results too high

Reason for error	Actions to be taken
The chemicals used are contaminated with nitrogen compounds.	Check the chemicals one after the other, get a blank value, a replacement of the chemicals might be recommended.
Strong reaction in the digestion tube, caustic soda drops got into the receiver.	Increase the amount of water.
Part of the glass condenser is broken, drops of the caustic soda got into the receiver.	Exchange the glass condenser.
Tubes are contaminated with nitrogen	Clean the tubes without detergent or rinsing agent.
Carry over of ammonia from the previous sample	Extent the distillation time or check whether sufficient alkali was added.

10.3. Results too low or no results

Reason for error	Actions to be taken
Distillation has not been complete or distillation time has been too short.	No quantitative carry over of the ammonia content, the amount of the distillate should be 100ml.
Ammonia escapes at leaks.	<ul style="list-style-type: none"> - Contaminated or defective viton cone; clean or replace. - Check seals at the distribution head and if necessary, replace it. - Non return valve at the condenser is bonded, clean or replace it. - Digestion tube is damaged at the wide neck opening. - Glass of the distribution head is leaking, replace it!
Amount of caustic soda which is added is too low, no release of ammonia.	Check the amount delivered by the NaOH pump; about 4 ml should be delivered per second.
Not enough boric acid in the receiver, escaping ammonia is not entirely absorbed.	Increase of the amount of boric acid.
Tube is not immersed entirely into the boric acid receiver.	Increase of the amount of acid.
Formation of ammonia complexes which are not destroyed by the caustic soda.	This problem only occurs with catalysts containing mercury, sodium thiosulphate solution destroys these complexes.

11 ITrouble shooting

10.4. Breakdown of operation

Error message	Reason for error	Actions to be taken
Excess current switch cuts off	Excessive current consumption	Switch on the switch again. Should the problem reoccur, call customer service.

10.5. Actions to be taken when distribution head is flooded

When the distribution head is flooded, the digestion tube cannot be taken out anymore, as chemicals might escape. Vapodest 20s is not provided with a suction so that you have to get ridd manually of excess chemicals using the ventilation of the steam generator at the back. In order to do so, please follow the procedure described below:

1. Connect water jet pump (as shown in ill. 10.5.A to the ventilation of the steam generator (you can also connect a hose pump for suction if there is one).
2. Start suction of the chemicals
3. Start cleaning program (see chapter 11.1.2. Cleaning program)
4. Take out digeston tube

Fig. 10.5.A
Connection of water jet pump

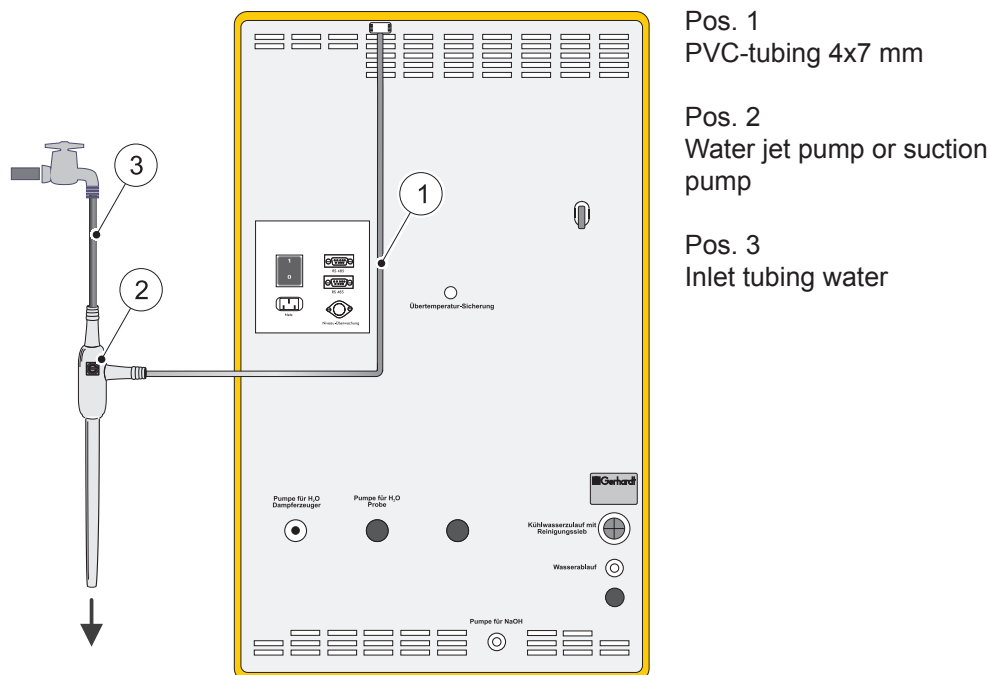

11 Maintenance

Please make sure that only original C. Gerhardt spare parts are used.

To minimize malfunctions of the VAPODEST, we recommend having it checked by authorized service personnel annually.

11.1. Cleaning and regularly check

11.1.1. Cleaning general

Make sure to wear gloves at all times when cleaning the components.

To avoid damage by corrosion, leaking liquids (especially acids and alkali) must be wiped off and neutralized immediately to prevent damage to casting, lacquer or housing.



Never use abrasive cleaners! In most cases it will be sufficient after each use to clean the plates using a moist cloth and some household washing-up liquid. Subsequently rub dry.

Condensate that might escape is collected in the drip tray. Please clean the drip tray regularly.

11.1.2. Cleaning program

Glass parts and suction pump should be cleaned before long periods of non-usage (i.e. holidays). This way blockages caused by crystalline deposits are avoided.

We suggest using the following programming:

Addition H ₂ O	ca. 120 ml (manual addition)
Addition NaOH	0 ml
Reaction time	0 s
Distillation time	7 min
Steam power	100 %
Suction time	20 s

Place an empty digestion tube and an Erlenmeyer flask into position, and start the program. In case of extreme deposits in the glassware you can clean the system by putting about 10 ml of sulphuric acid into the digestion tube.

11.1.3. Check the tight fitting of the tubes

The connection of the tubes at the rear of the instrument has to be checked once a month to ensure tight fitting. Should the tubes become loose eventually, they can be secured with a hose clamp.

11 Maintenance



11.2 Tubing diagram Vap 20 s (with open rear wall)

Das Öffnen des Gerätes darf nur von einer autorisierten Fachkraft durchgeführt werden.

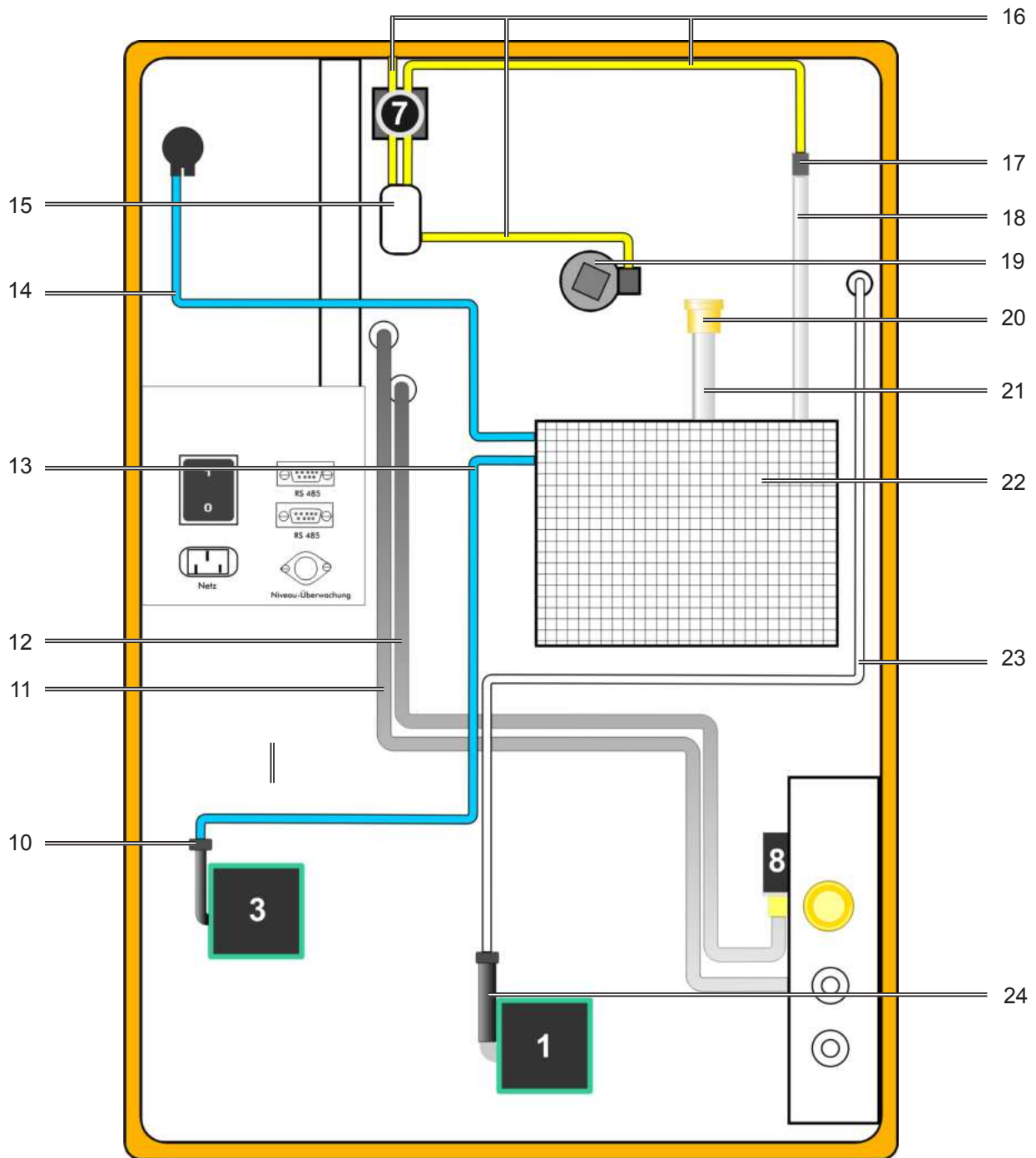

11 Maintenance

11.2.1. Description of the tubing diagram

Pos.	Description	Item-No.
1	Diaphragm pump NaOH	1001738
2	-	
3	Diaphragm pump H ₂ O for steam generator	1001736
4	-	
5	-	
6	-	
7	Magnetic valve with pressure control	1000363
8	Pinch-solenoid valve, shut-off	1000090
9	-	
10	Non-return valve for diaphragm pumps	1000081
11	Silicone tubing 8 x 16 for cooling water outlet	1000497
12	Silicone tubing 8 x 16 for cooling water outlet	1000497
13	Silicone tubing 4 x 7 mm	1000488
14	Silicone tubing 4 x 7 mm	1000488
15	Ventilation glass	1000048
16	Novoprene-tubing 4,8 x 8 mm	1002289
17	Tubing reduction	1000397
18	Silicone tubing 6 x 10 mm	1000484
19	PP-distributor with PP-thread	1000538
20	NKT-valve (built in with brass fitting)	1002842
21	Silicone tubing 8 x 16 x 80 mm	1000497
22	Steam generator	1000232
23	PTFE-inlet tubingh NaOH	1003401
24	Vitone-tubing 6 x 12 * 50 mm	1000495

When you order additional tubing, please make sure to also give the desired length!

11 Maintenance

11.3. Spare parts

Description	Item-No.
Distillation condenser, glass	1000058
Plastic screw connection for distillation condenser	1000358
Ventilation valve	1000036
Distribution head, glass	12-0363
Vitone cone	12-0351
PTFE-inlet tubing, steam	1002178
Teflon sieve for item-no. 1002178	1000630
PTFE-inlet tubing, NaOH	1003401
PP-distributor	1000538
PP-tube joint	1000250
Screw cap GL 14, white	1004320
Screw cap GL 18, white	1004321
Screw cap GL 32, white	1004322
Silicone-/PTFE-seal GL 18	1000356
Silicone-/PTFE-seal GL 32	1000357
Plexiglass protection door	1001236
Door handle	1000392
Door hinges, 1 pair	1000391
Drip tray, PP	1000399
Mains switch	1004331
Control panel	1004116
Knob for operator button	1004325
Excess current switch, 10A	1001358
Tubular heating element for steam generator	1000259
Steam generator	1000232
Excess pressure valve, steam generator	1000483
Mains cable	10-0057
Magnetic valve with pressure control	1000363
Micro switch for quick clamping device	1000290
Pinch-solenoid valve steam and shut-off	1000090
Ventilation glass	1000048
Diaphragm pump for NaOH	1001738
Diaphragm pump for H ₃ BO ₃ or H ₂ O	1001736
Peristaltic pump	1000084
Tubing	
Water inlet tubing 10/17, 2 m	1000394
Silicone tubing 6 x 10	1000484
Silicone tubing 8 x 12	1000496
Silicone tubing 4 x 7	1000488
Silicone tubing 8 x 16	1000497
Novoprene-tubing 4,8 x 8	1002289
Verprene-tubing 4 x 8	1000498
Verprene-tubing 8 x 12	1000499

11 Maintenance

PTFE-tubing 4 x 6 x 135	1000559
Description	Item-No.
PVC-tubing 4 x 7	1000500
PVC-tubing 8 x 12	1000047
Tubing reduction, PP 51 x 10 x 10	1000397
Tubing reduction, PP 51 x 10 x 5	1000398
PVC-pipe 6 x 1, 400 mm	1000566
PVC-pipe 10 x 1, 400 mm	1000567

11.4. Accessories

Set of storage tanks KAN 20 complete with:	12-0382
- Storage tank 20 l for H ₂ O	
- Storage tank 20 l for NaOH	
- Level sensor with plug for all tanks	

Spare parts for storage tanks KAN 20	
Level sensor with plug for H ₂ O and NaOH-tank	1002124
Level sensor with plug for „Sample waste“ tank	1002125
Level sensor with plug for titration tank	1002126

Upgrade kit Micro	
Viton cone VK, micro, for 100 ml tubes KMT	12-0352

More accessories

Tubes	
250 ml, KTG 250 standard version	12-0301
400 ml, KDD 400 standard version	12-0310
800 ml, KDD 800 standard version	12-0311
400 ml, BS 400 special version, diminished	12-0308

EDV	
Data cable DK 42 for RS 485, 2 m	10-0192
Data cable DK 45 for RS 485, 5 m	10-0193
Terminator plug AST for RS 485	10-0196
RS-Adapter	10-0190

Further accessories and information about the Vapodest program can be found in the product catalogue or at your local dealer!

12 Decommissioning and disposal

12.1. Decommission

In case of shipment, of repair or disposal, the instrument has to be taken out of operation and has to be cleaned (decontaminated). Please contact customer service of your dealer or C. Gerhardt, to terminate the operation of the instrument.

12.2. Contact service

In case of more problems or failures of your Vapodest 50s carousel, please contact your local dealer or:

C. Gerhardt GmbH & Co. KG
Cäsariusstr. 97
D-53639 Königswinter

Tel.: +49 (0)22 23 - 29 99 0
Fax: +49 (0)22 23 - 29 99 99
info@Gerhardt.de
www.gerhardt.de

12 Decommissioning and disposal

12.3. Disposal

The disposal of the packaging and the parts used has to be done according to the rules and regulations which are valid in the country of installation. Should the product itself be disposed of, make sure to observe the local rules and regulations.

12.3.1. Information for the Disposal of Electric and Electronic Instruments within the European Union

The disposal of electrically operated instruments is settled within the European Union by national regulations, which are based on the EU-directive 2002/96EC about electric and electronic used-instruments (WEEE). Thus, all instruments delivered after August 13th 2005 must not be disposed into the communal domestic waste.



Since the regulations about disposal of waste might vary from one country to the other within the European Community, we kindly ask you to contact your supplier or dealer.

In Germany, this obligation for identification is valid as of March, 23rd 2006. As of this date, C. Gerhardt takes back all instruments delivered after August, 13th, 2005 without charges and will dispose of them according to the regulations, or Gerhardt will come to an agreement with the last user of the unit. For all instruments delivered prior to August 13th, 2005 the last user will be held responsible for the proper disposal. The only crucial factor accepted, for the chronological placement, is the serial number at the back of the instrument.

12.3.2. Ban on Materials according to ROHS Regulation 2002/95/EG

Ban on materials from the ROHS regulation 2002/95/EG is not valid for the electro- and electronic instruments of category 8 and 9 and thus not for those instruments described in this instruction manual. However, we want to draw your attention to the fact that we feel obliged to observe the regulations for the RoHs for all our products. Please be kind enough to contact us if you have any further questions.

12.3.3. Transfer

We kindly ask you to always make sure to add this instruction manual to the product in case of transferring it to another party.

