

Vapodest 30

Instruction Manual



Please read this instruction manual with care before you start operating the system

Please observe the safety instructions of this manual, marked with  in order to avoid any dangerous handling!

Vap 30
Order no.: 7630



LAB Online Exhibition



Contents

	Safety	3
	Application as directed	3
	Safety instructions	3
	1 Technical description	4
	Warranty conditions	4
	Technical data	4
	Operating conditions	5
	2 Description of the system	6
	Front view	6
	Rear view	8
	3 Delivery	10
	Check for transport damage	10
	Parts list	10
	4 Assembly and installation	11
	Setup	11
	Setting into operation	12
	5 Programming the system	14
	Keyboard	14
	Programming the Vapodest 30	17
	On-line mode	19
	6 Operation	21
	Safety instructions	21
	Priming the system	21
	Test run	22
	Distilling a sample	23
	7 Error messages	24
	8 Maintenance	26
	Tubing diagram	26
	Spare parts and accessories	28
	Service and cleaning	30
	Trouble shooting	30

Safety

Application as directed

With the Vapodest 30 you have purchased an automatic distillation system for the steam distillation of Kjeldahl digestions and associated distillations. Automatic addition of NaOH and H₂O as well as removal of the sample remains after distillation by suction.

Safety instructions

Make sure that no liquid gets into contact with cable connections or the interior of the electrical parts of the unit!
Danger of electrical shock!



For repairs on electrical, electronic or mechanical parts please always contact your agent's service. Don't do repairs by yourself!



Always switch off the apparatus at the mains and pull out the plug before opening! Danger of electrical shock!



The Vapodest 30 must not be run in damp or hazardous location. The maximum humidity allowed is 80 %, the maximum ambient temperature must not exceed 40 °C!



The apparatus must not be exposed to aggressive vapours of acids, alkalies or solvents.



The apparatus must be used according to this instruction manual. It is not allowed to supply changes to the apparatus in order to modify its application.



1 Technical description

Warranty conditions

Warranty The Vapodest 30 is manufactured following the high quality guidelines of DIN EN ISO 9001.
 On the basis of the C. Gerhardt conditions of warranty our products are guaranteed for 1 year, as long as the apparatus is used in accordance with the instructions mentioned in this manual.
 Please note that the semi-consumable parts are excluded from warranty.

Technical data

<i>Distillation</i>	Voltage:	230 V AC, 50 Hz
<i>System</i>	Wattage:	1600 W
	Cooling water:	about 3 litre per distillation minute
	Cooling wat. pressure >	1,3 bar
	Pump capacity:	
	-Diaphragm pump	about 10 ml/s
	-Peristaltic pump	about 10 ml/s
	Store tank:	any size, recommended: KAN 30
	Micro controller:	Single-chip MCU
	Display:	5 x 7 LED
	Program:	1
	Interface:	RS 485
	Dimensions:	440 x 690 x 340 mm (W x H x D)
	Weight:	27 kg
 <i>Interface</i>	 Baud-rate:	 9600
	Data-bits:	8
	Parity:	No
	Start bit:	1
	Stop bit:	1
	Mode:	Semi-Duplex
	User:	Maximum 32
	Connection:	D-Sub 9-pin acc. to DIN 41 652

Pin-assignment: 1 – shield
..... 2 – N/C
..... 3 – B driver-Out/receiver-In
..... 4 – N/C
..... 5 – GND
..... 6 – VCC
..... 7 – N/C
..... 8 – A driver-Out/receiver-In
..... 9 – N/C

Pin-assignment

Operating conditions

Vapodest distillation systems can be run under normal laboratory conditions.

For the connection to the tap (cold water) a fixed connection with 1/2 inch thread is needed.

2 Description of the system

Front view

Structural components and parts:

- 1 Quick clamping device with wedge
- 2 Kjeldatherm digestion tube, 250/100 ml or flask, 500/750 ml, with enlarged neck or KDD 400/800
- 3 Holder for steam inlet tubing
- 4 PTFE-inlet tubing, steam
- 5 Viton-cone, macro or micro

- 6 Clamping for glassware
- 7 Screw cap GL 18 with silicone seal
- 8 PTFE-inlet tubing, NaOH
- 9 PP-distributor with PP-threaded joint
- 10 Distribution head, glass

- 11 Screw cap GL 32 with silicone seal
- 12 Distillation condenser
- 13 Screw cap GL 14 with plastic screw connection
- 14 Display
- 15 Keyboard, chemical-resistant

- 16 Mains switch, green, illuminated
- 17 Ventilation valve
- 18 Distillate outlet tubing, silicone 8/12 mm
- 19 Erlenmeyer flask
- 20 Platform

- 21 Drip tray
- ** Plexiglass protection door, top (not illustrated)
- ** Plexiglass protection door, bottom (not illustrated)
- ** New, plexiglass protection door, single (not illustrated)

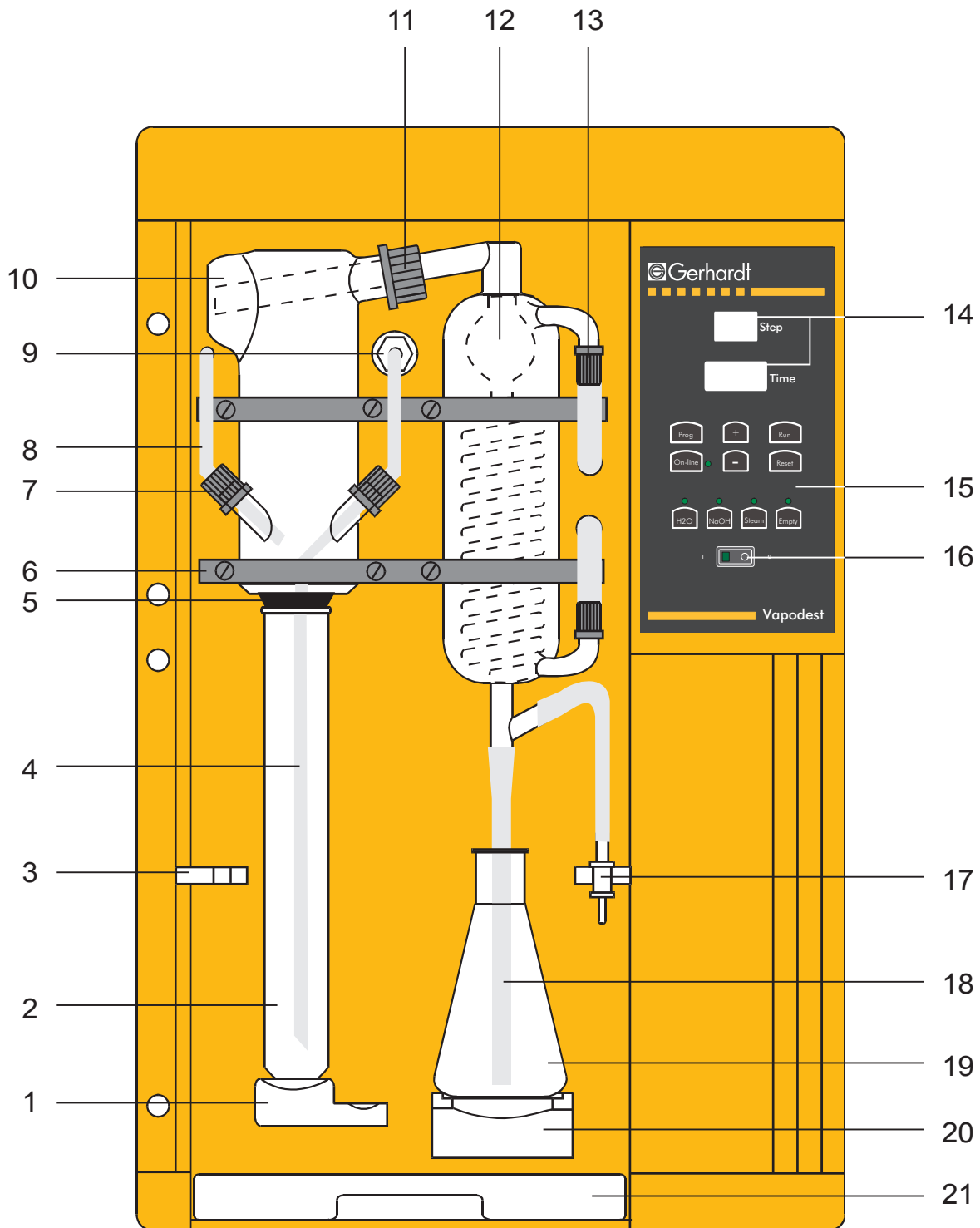

Fig.2.1: Front view Vapodest 30

Rear view

Description of the connections:

- 1 Diaphragm pump for H₂O sample:
.... Connection pipe for PVC-tubing 4/7 mm
- 2 Diaphragm pump for H₂O steam generator:
.... Connection pipe for PVC-tubing 4/7 mm
- 3 Level detector:
Connection socket for diode plug, 3-pin
(level detector for set of tanks KAN 30)
- 4 Mains cable with appliance plug
- 5 Excess current switch, 10A
.... Cuts off in case of excessive current consumption
- 6 RS 485 interface
- 7 Outlet ventilation tubing
- 8 Excess pressure - steam outlet
- 9 Excess temperature fuse
- 10 Cooling water inlet with sieve:
.... Connection thread 3/4 inch for water inlet tubing 10x17
- 11 Water outlet:
.... Connection pipe for PVC-tubing 8/12 mm
- 12 Peristaltic pump for sample suction
.... Connection pipe for Verprene tubing 8/12 mm
- 13 Diaphragm pump for NaOH:
.... Connection pipe for PVC-tubing 8/12 mm

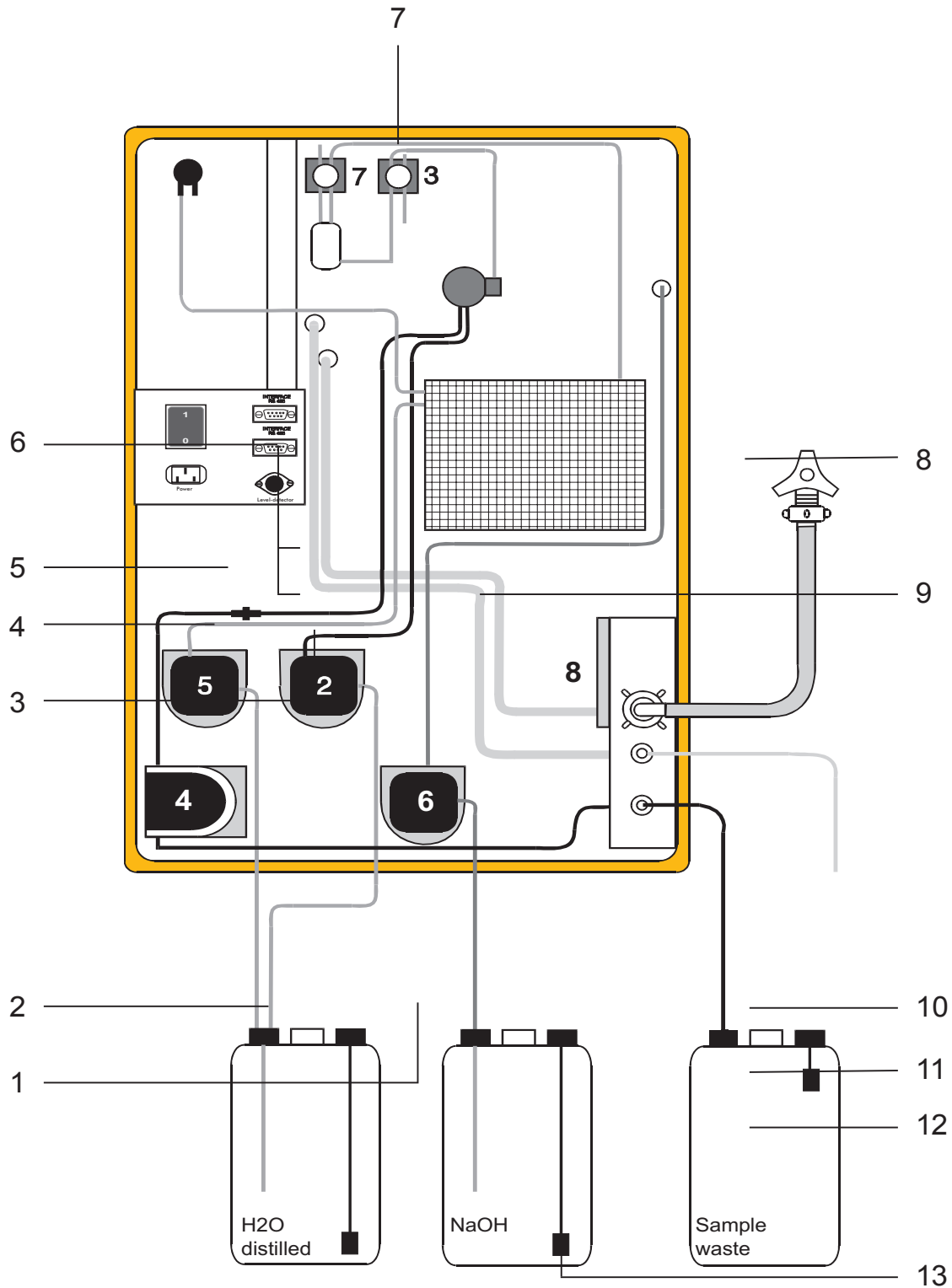

Fig.2.2: Rear view Vapodest 30

3 Delivery

Check for transport damage

Before assembling the instrument please check if the contents of the box is complete and intact!

In case of any damage, please notify your carrier (post, rail, road) and obtain an expert's report!

The exact contents of the delivery can be checked by the following list.

Parts list

- Distillation system Vapodest 30, complete

- Tubing set:
 - 1 x Water inlet tube 10/17mm with connections of 1/2 inch and 3/4 inch, 2m
 - 1 x Verprene tube 8/12 mm. 2 m
 - 2 x PVC tube 4/7 mm, 2 m
 - 2 x PVC tube 8/12 mm, 2m
 - 2 x PVC pipe 6 x 1 mm, 420 mm
 - 1 x PVC pipe 10 x 1 mm, 420 mm

- 1 x Mains cable

- 1 x Kjeldatherm digestion tube 250 ml or 100 ml

4 Assembly and installation

Setup

Please observe the local water and waste regulations and those of your public water supply enterprise!



Please note that the length of the inlet and outlet tubing is restricted to 2 metres.

The appliance should be located on a fixed laboratory bench, close to the cold water connection and a drain.

There should be sufficient space for the set of tanks below the work bench.

Connect the water inlet tubing to a dedicated cold water tap.

The water pressure must be at least 1,3 bar in order to operate the integrated pressure controller.

The Vapodest 30 comes completely preassembled. Please unpack the instrument with care!

1. Place instrument on work bench
2. Unpack accessories.
3. Place set of tanks for distilled water, sodium hydroxide and sample waste below the bench.

Installation

Make sure that the set of tanks are not placed any higher than the distillation unit!

4. Connect the pump tubes (connections are marked at the rear of the apparatus) to the PVC-pipes of the chemical tanks:
 - Inlet tubing sodium hydroxide (PVC-tubing 8/12 mm)
 - Inlet tubing for distilled water steam generator (PVC-tubing 4/7 mm)
 - Inlet tubing for distilled water sample (PVC-tubing 4/7)
5. Connect the water inlet tubing
 - Connect water inlet tubing (pressure-proof tissue tubing 10/17 mm) to cooling water inlet and laboratory water supply

Tubing connections

6. Connect the outlet tubing:
 - Connect water outlet tubing (PVC-tubing 8/12 mm) to connection pipe at the rear and place in the drain
 - Connect sample waste outlet (Verprene-tubing 8/12 mm) to pipe at the rear and direct to sample waste tank/drain



Please check the nominal voltage on the type plate before connecting to the mains.

7. Mains connection
 - Make sure that the mains switch at the front of the instrument is in position „0“
 - Connect the mains cable to the rear appliance plug first
 - Connect the mains cable to a shockproof socket
8. Use of the set of tanks KAN 30 (optional)
 - Connect the diode plugs of the level detectors to the distribution box and connect to the socket level detection (at rear)
 - Blank off the remaining diode sockets of the distribution box with the dummy diode plugs enclosed.
9. Excess current switch
 - Before you first take the Vapodest into operation make sure that the excess current switch at the rear is in position 1.

Setting into operation



Attention when working with acids and alkalies! Make sure you observe the safety instructions concerning work with hazardous materials!



Always close the plexiglass doors of the distillation unit before operating!

1. Fill the set of tanks with chemicals:
 - H₂O distilled or demineralized
 - NaOH 32 %

2. Turn on the water tap

3. Initial filling of steam generator



- When using the set of tanks KAN 30:
Press the key „+“ ((keep pressed), and switch on the instrument

- When using other reservoirs:
Press the key „-“ (keep pressed), and switch on the instrument



Please note that these key combinations are only used for the initial filling of the steam generator. For subsequent operations the instrument is switched on via the mains switch!

- After switching the unit on the pump that fills the steam generator starts immediately, and the display shows the error message „E3“ (lack of water in the steam generator)
- Press key „Run“ (only for initial filling)



The steam generator is filled with water up to a preset level, which then causes the pump to switch off.

4. Monitoring the status notice on the display:

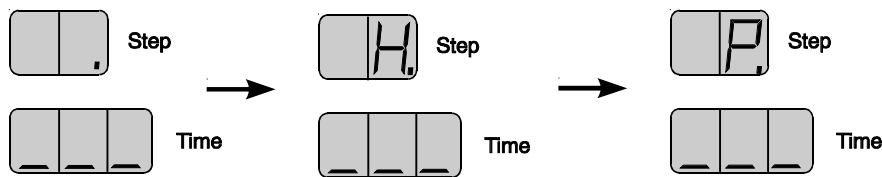

The Vapodest 30 is now ready for operation.

5 Programming the system

Keyboard

The Vapodest 30 can be programmed and controlled via the keyboard of the control panel.

Keyboard

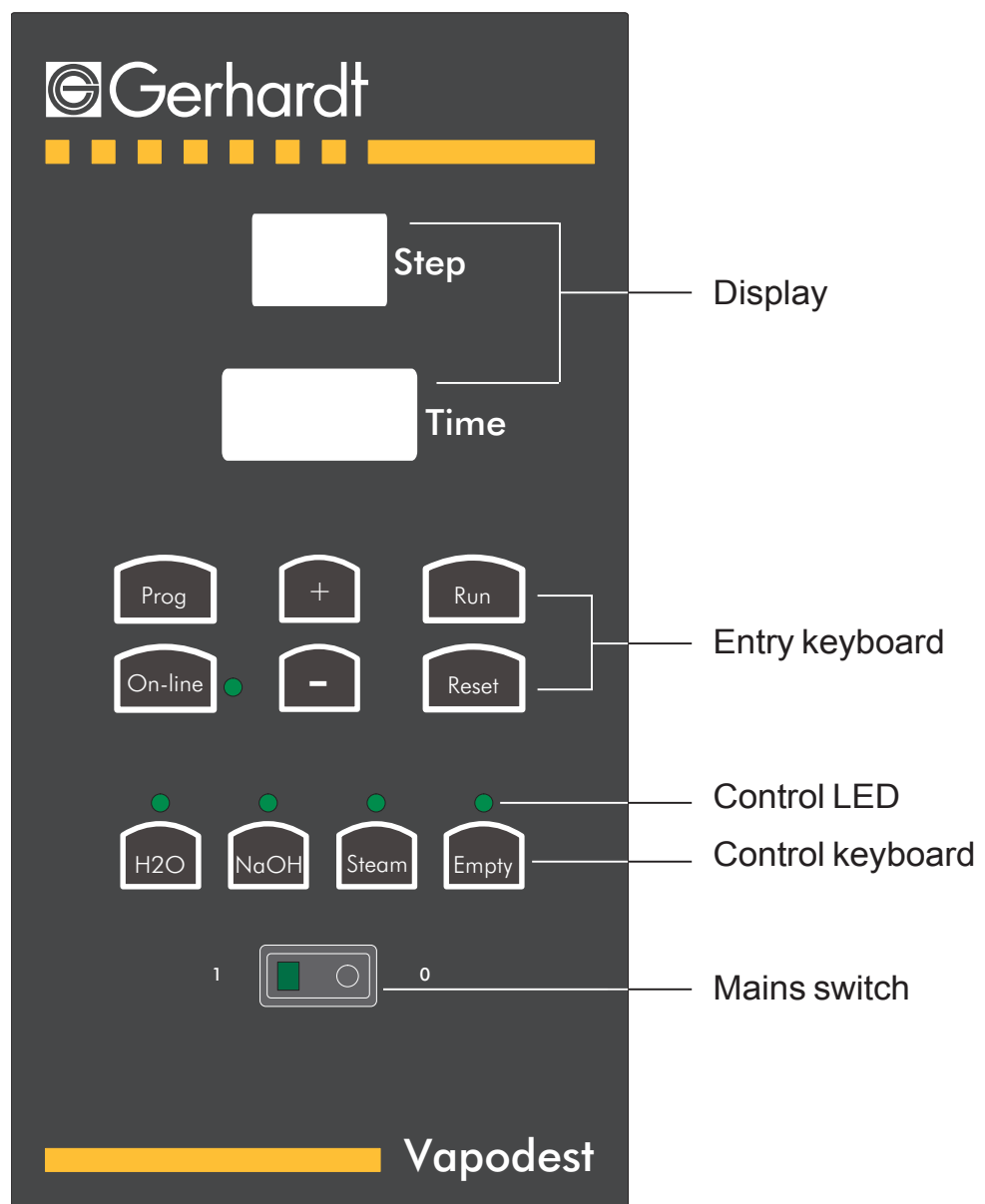















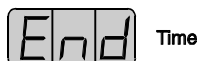











Fig 5.1: Control panel keyboard







Display/Keys	Meaning within program mode
 Step	Display program step
 Time	Time in seconds or minutes, The Vapodest is delivered with the second-mode. In order to be able to switch between the second- and the minute-mode, please proceed as described: - Press the key 'Prog' when turning on the instrument - Display point flashes
	Prog: check, memorize and confirm programm <i>Program mode</i>
	Run: Start data transfer in synchronous mode (on-line activated))
	„+“: Increasing actual value to desired value
	„-“: Decreasing actual value to desired value
	Reset: Interruption of programming, return to start position
	Key On-line pressed: Control LED illuminated, RS 485 interface is activated
	Programming status H2O: Control LED flashes
	Programming status NaOH: Control LED flashes
	Programming status distillation: control LED flashes
	Programming status suction: control LED flashes

Display/Key	Meaning in Run mode
 Step	Display program step Display point flashes
 Time	Time in seconds or minutes
 Step	Display program end
 Time	
<i>Run mode</i>	
	–
	Run: Starting and repeating of program
	–
	–
	Reset: Interruption of program and return to start position
	On-line key pressed: Control LED illuminated, RS 485 interface is activated
	Program step H ₂ O addition: Control LED illuminated
	Program step NaOH addition: Control LED illuminated
	Program step distillation: Control LED illuminated
	Program step suction: Control LED illuminated

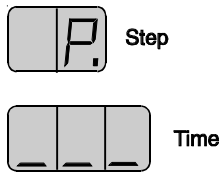
Programming the Vapodest 30

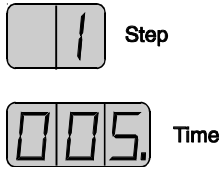

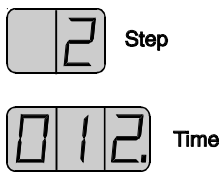





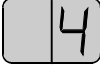
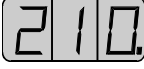

Each Vapodest undergoes a pre-delivery performance test in the quality assurance department before leaving C. Gerhardt. On arrival the machine is supplied with the test program.

If you wish to keep this program, please confirm the program steps with the „Prog“ key. If changes are required, please press either the „+“ or „-“ keys at the relevant step, and then store with the „Prog“ key.

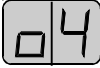
Step	Program status	Time	Confirmation
Start	Start position 		
1	Addition H ₂ O 	Range: 0 to 30 s Preset: 5 s	
2	Addition NaOH 	Range: 0 to 30 s Preset: 12 s	

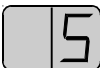
Programming the distillation system

Programming the distillation system

3	<p>Reaction time</p>  Step  Time	<p>Range: 0 to 999 s in second-mode or 0 to 99,9 min in minute-mode</p> <p>Preset: 0 s</p>	
4	<p>Distillation time</p>  Step  Time	<p>Range: 0 to 999 s in second-mode or 0 to 99,9 min in minute-mode</p> <p>Preset: 210 s</p>	
4*	<p>Power</p>  Step  Time	<p>Range: 35 to 100 %</p> <p>Preset: 100 %</p>	
5	<p>Suction</p>  Step  Time	<p>Range: 0 to 999 s</p> <p>Preset: 25 s</p>	
Prog. End	<p>Start position</p>  Step  Time		

On-line mode

The RS 485 interface allows quality assurance conforming to ISO/GLP. It enables up to 32 different instruments (including other makes) to be connected between each other.

The on-line mode provides the following possibilities:

1. Connection of personal computer for controlling and monitoring in conjunction with the GerLab® user program. *Control via PC*
2. Connection of PC for controlling and monitoring in conjunction with a customised terminal program, i.e., Telix (MS-DOS), Terminal (for Windows). With the assistance of the interface a program, based on the customers' needs, can be written, too.
3. Synchronous working of various equipment. The programming and controlling is effected via a system, which has been appointed semi master. *Synchronous mode*

The working instructions for the synchronous mode are as follows:

- Connect all instruments with the interface cables RS 485
- Provide the last unit connected with the terminator AST
- Activate the on-line key of each instrument (control LED illuminated)



- Determine the semi master by pressing the keys „+“ (keep pressed) and on-line (control LED flashes)



By pressing this key-combination once more you can return to the simple on-line position (Control LED illuminated).

- Programme the semi master as described in the previous paragraph
After having confirmed program step 5 the following is shown on the display:

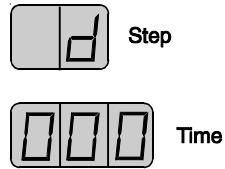

- Press the „Run“ key to initiate the data transfer from the semi master to the connected instruments

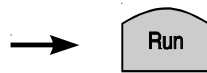

- After the termination of the data transfer the programming mode automatically ends, and the display shows the start position:

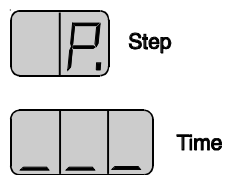

Further information about GerBus® and GerLab® can either be obtained from C. Gerhardt GmbH & Co. KG or our appointed dealer!

6 Operation

Safety instructions

Attention when handling acids and alkalies! Please observe your national safety regulations!



Use gloves when removing the glass digestion tube as this will be very hot, and there is danger of burning!



Take care when handling glass parts and follow the national safety regulations concerning the handling of glass parts!



Priming the system

Please make sure that the system is fully primed. This must be performed before for the initial start, after longer working intermissions (holidays etc.) and each time after the inlet and outlet tubes have been removed.

1. Check the chemical tanks.
2. Turn on the tap.
3. Insert the inlet tube into an empty digestion tube.
4. Lower the quick clamping device and insert the digestion tube.
5. Ensure there is a tight fit between the tube and the Viton cone.
6. Insert the distillate outlet tube into an empty Erlenmeyer flask, and place the flask into position.
7. Close the protection door, and switch the distillation system on.
8. Keep the key „H₂O“ pressed until the water runs into the digestion tube.
9. Keep the key „NaOH“ pressed until the sodium hydroxide solution runs into the digestion tube.

Priming

10. To empty the contents in the digestion tube press the key „Empty“
11. Remove the digestion tube and the Erlenmeyer flask

The distillation system Vapodest 30 is now primed.

Test run



Each day before starting to distill samples you should do a distillation without sample.

Don't be disturbed by noises deriving from the approx. 106 °C hot steam being led into the digestion tube.

The test run can be interrupted any time by pressing the key „Reset“.

- Test run*
1. Check the chemical tanks.
 2. Turn on the tap.
 3. Insert the inlet tube into an empty digestion tube.
 4. Lower the quick clamping device and place the digestion tube into position.
 5. Ensure there is a tight fit between the tube and the Viton cone.
 6. Insert the distillate outlet tube into an empty Erlenmeyer flask, and place the flask into position.
 7. Close the protection door, and switch the distillation system on.
 8. Start the program with „Run“ or enter the program required.
 9. View the program on the display until the program end is shown to ensure it is correct.
 10. Lower the quick clamping device and remove the digestion tube.
 11. Place the inlet tubing into the holder.

The Vapodest 30 is now ready for the sample distillation

Distilling a sample

This program can be interrupted any time by pressing the key „Reset“.









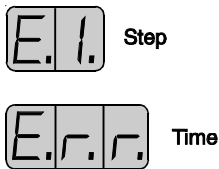
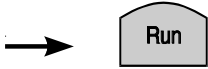
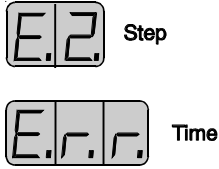
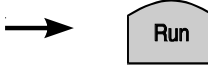
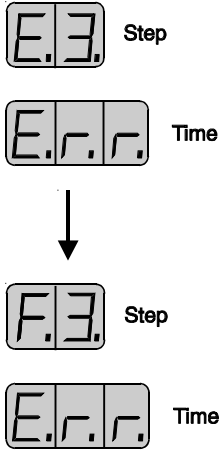
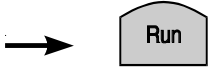
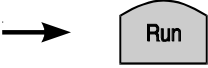
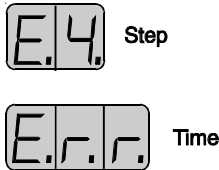

1. Prepare the receiver solution: *Distillation*
Fill an Erlenmeyer flask with about 50 ml boric acid and place into position.
2. Place the steam inlet tube into the sample tube filled with sulphuric acid digestion.
3. Lower the quick clamping device and place the digestion tube into position.
4. Check the tight fit of the tube against the Viton cone.
5. Close the protection door and switch the instrument on.
6. Enter the program required, and start with the key „Run“.
7. Once the program has finished the program remove the digestion tube by lowering the quick clamping device.
8. Place the steam inlet tube into the holder.
9. Remove the Erlenmeyer flask with the distillate and continue the determination.

If you wish to keep this program and distill further samples, please press the key „Run“. If you wish to change the program, reprogramme the system. If you have finished all distillations, switch the unit off.

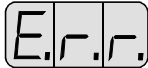
7 Error messages

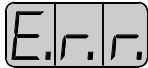
The micro-processor continually surveys all the functions of the distillation system. As soon as an error arises it is shown on the display and accompanied by an acoustic signal.

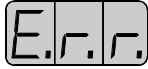
Error messages	Cause of error	Measures
 <p>E.1. Step E.r.r. Time</p>	No cooling water	Check cooling water inlet, display flashes 
 <p>E.2. Step E.r.r. Time</p>	No sample tube (start of distillation not possible)	Insert tube, display flashes 
 <p>E.3. Step E.r.r. Time ↓ F.3. Step E.r.r. Time</p>	Lack of water in the steam generator Filling of the steam generator	Check the water inlet distilled H ₂ O  Display shows last step, flashes on stand by 
 <p>E.4. Step E.r.r. Time</p>	Sensor error (water level in steam generator is no longer measured)	Switch the system off and call service

Error message	Cause of error	Measures
 Step  Time	Program undefined	 → Check programming
 Step  Time	Wait for stand-by	Message disappears as soon as stand-by is reached
 Step  Time	Excess steam pressure	Switch the system off and call service
 Step  Time	Lack of chemicals	Check set of tanks, Display flashes → 

8 Maintenance



In case of necessary replacements, please make sure that only original C. Gerhardt spare parts are used!

Tubing diagram

The pumps and the valves of the instrument are marked with reference numbers.

Descriptions of the structural components (rear - interior of instrument):

- 1 PVC-pipe 6x1 mm, 400 mm
- 2 PVC-pipe 10x1 mm, 400 mm
- 3 PVC-tubing 4/7 mm
- 4 Verprene tubing 4/8 mm
- 5 Peristaltic pump suction (pos.4)
- 6 Diaphragm pump NaOH (pos. 6)
- 7 Diaphragm pump H₂O sample (pos.2)
- 8 Diaphragm pump H₂O steam generator (pos. 5)
- 9 Silicone tubing 4/7 mm
- 10 Tubing reduction PP 51x10x5 mm
- 11 Verprene tubing 8/12 mm
- 12 Inlet condenser, Silicone tubing 8/16
- 13 Outlet condenser, Silicone tubing 8/16
- 14 Ventilation glass
- 15 Pinch-solenoid valve, shut-off (pos. 3)
- 16 Pinch-solenoid valve, steam(pos. 7)
- 17 Novoprene-tubing 4,8x1,6 mm
- 18 PP-distributor with PP-thread
- 19 PTFE-inlet tubing NaOH
- 20 Steam generator
- 21 Water inlet tubing 10/17 mm
- 22 Magnetic valve cooling water (Pos. 8)
- 23 Outlet tubing, PVC 8/12 mm
- 24 PVC-tubing 8/12 mm
- 25 Verprene tubing 8/12 mm
- 26 Level detector for sample waste tank
- 27 knurled knob with socket
- 28 Level detector for chemical tanks

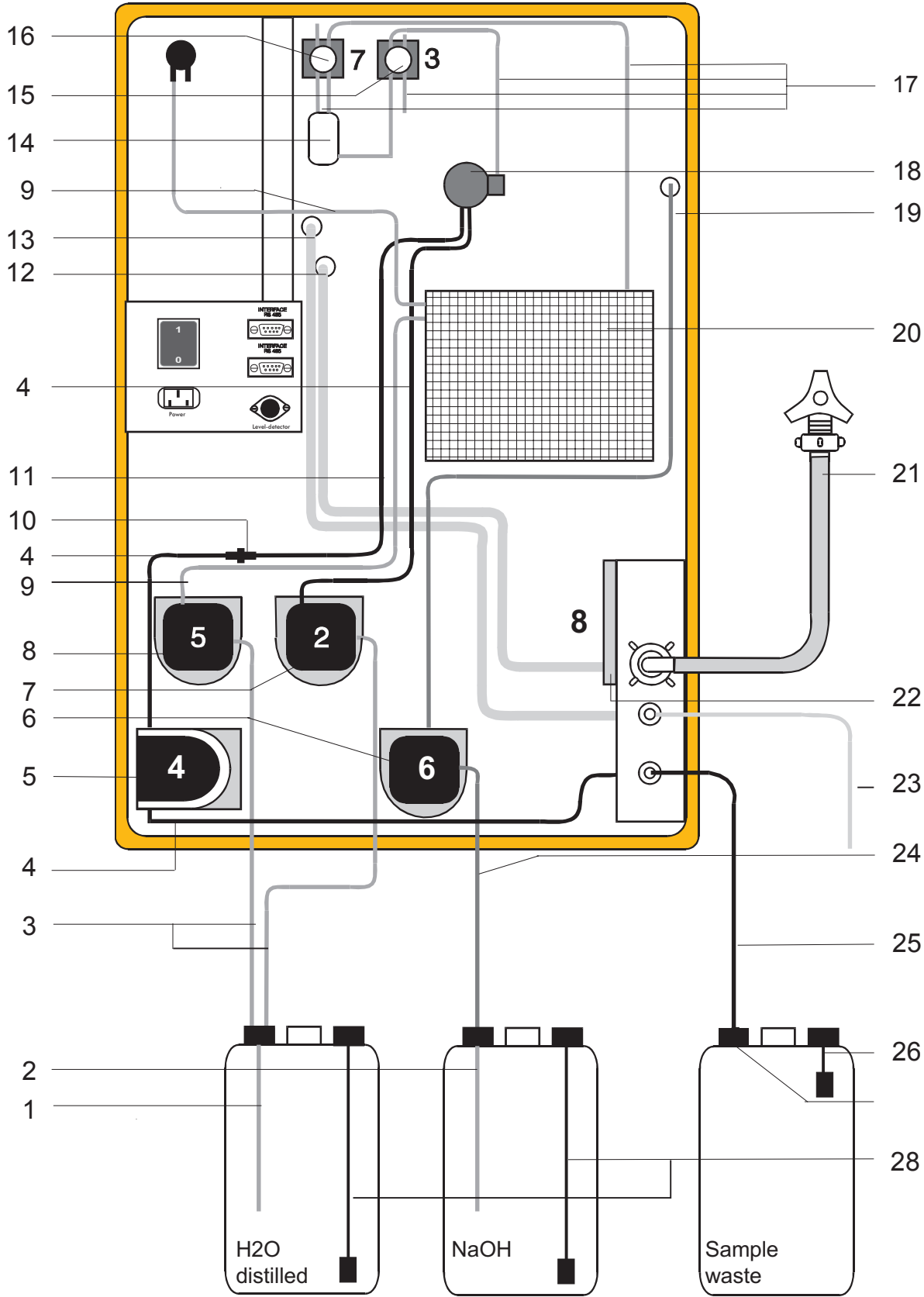

Fig 8.1: Tubing diagram

Spare parts and accessories

	Parts description	Order no.
<i>Spare parts</i>	Distillation condenser	7673
	Plastic screw connection for distillation condenser	16609
	Ventilation valve	6474
	Distribution head, glass	7472
	Viton cone	6470
	PTFE-inlet tubing, steam	11810
	Teflon sieve for 11810	30698
	PTFE-inlet tubing, NaOH	11811
	PP-distributor	50024
	PP-tube joint	17542
	Screw cap GL 14	16601
	Screw cap GL 18	16602
	Screw cap GL 32	16604
	Silicone seal GL18	16606
	Silicone seal GL 32	16607
	Plexiglass protection door, top	19016
	Plexiglass protection door, bottom	19015
	New, plexiglas protection door, single	19017
	Door handle, brown	18251
	Door hinges, brown, 1 pair	18250
	Rubber foot GF21, self-adhesive	17945
	Drip tray, PP	50015
	Mains switch, green, illuminated	11750
	Keyboard	11214
	Control PCB	11222
	Excess current switch, 10 A	15378
	Heating element	12354
	Steam generator	40850
	Excess pressure valve, steam generator	20604
	Ventilation valve WMF	20620
	Power PCB, 230 V	11223
	Mains cable	1311
	Magnetic valve with pressure control	17109
Semiconductor relay WG-A5-6D25	15350	

Parts description	Order no.	
Micro switch for quick clamping device	13308	
Pinch-solenoid valve steam	10385	
Ventilation glass	40272	
Diaphragm pump PML 1140-ND 100	10310	
Peristaltic pump	10360	
Water inlet tubing 10/17 mm, 2 m	22802	
Silicon tubing 8/12 mm, 2 m	22704	
Novoprene-tubing 4,8x1,6 mm	20919	
Verprene-tubing 4/8 mm	20920	
Verprene tubing 8/12 mm	20921	
Tubing reduction PP 51x10x10 mm	50022	
Tubing reduction PP 51x10x5 mm	50023	
PVC-tubing 4/7 mm, 2 m	22601	
PVC-tubing 8/12 mm, 2 m	22604	
PVC-pipe 6x1 mm, 400 mm	25450	
PVC-pipe 10x1 mm, 400 mm	25451	
Set of tanks KAN 30, 3 pieces with float switch	7639	<i>Accessories</i>
RS 232/485 ARS	4260	
Data cable DK 42 for RS 485, 2 m	4261	
Data cable DK 45 for RS 485, 5 m	4262	
Data cable DK 22 for RS 232, 2 m	4264	
Terminator AST	4265	
Viton cone VK, micro, for 100 ml tubes KMT	7671	<i>Modification accessory Micro</i>
PP-distribution head Devarda VPD 7, bottom part	7474	<i>Modification kit Devarda</i>
Glass PP-distribution head Devarda VGD 7, top part	7475	
Ventilation valve condenser (glass)	30244	
Condenser, shortened	7676	
PP-adaptor	40213	
PP-distribution head distance piece	50025	
Screw cap GL 32, open version	16604	
Silicone seal GL 32	16607	

Service and cleaning

Condensate that might escape is collected in the drip tray. Please clean the drip tray regularly.

Regularly check the consistence of the tubing and tubing connections.

Glass parts should be cleaned before long periods of non-usage (i.e. holidays). This way obstructions caused by crystalline deposits are avoided.

The following program should be run:

Addition H ₂ O:	13 s
Addition NaOH:	0 s
Reaction time:	0 s
Distillation time:	420 s
Steam capacity:	100 %
Suction time:	20 s or 0 s

It is recommended that the NaOH line is flushed daily so that no NaOH is left in the chemical lines overnight.

Place an empty digestion tube and an Erlenmeyer flask into position, and start the program.

Trouble shooting

Excess current switch The excess current switch cuts off in case of excessive current consumption. Switch on the excess current switch again. If this problem reoccurs, call service!

Service In case of a breakdown or a failure of your distillation system Vapodest 30, please contact your local dealer or:

C. Gerhardt GmbH & Co. KG

Cäsariusstr. 97
53639 Königswinter

E-Mail: info@Gerhardt.de
www.gerhardt.de

