

S-Bt Smart BioTherm Compact CO₂ Incubator





LAB Online Exhibition



Contents

1.	About this edition of user instructions.....	4
2.	Safety precautions	4
3.	General information.....	6
4.	Getting started.....	7
5.	Operation	8
6.	Fault diagnostics	12
7.	Specifications	13
8.	Ordering information	14
9.	Care and maintenance	15
10.	Warranty.....	17
11.	Notes.....	18
12.	EU Declaration of conformity.....	19

1. About this edition of user instructions

The current edition of the user instructions applies to the following models and versions of Compact CO₂ Incubator:

- **S-Bt Smart Biotherm**..... V.1AW, V.1AE

2. Safety precautions



Caution!

Make sure you have fully read and understood the present Manual before using the equipment. Please pay special attention to sections marked by this symbol.



Caution!

Biohazard. Incubator operations should comply criteria of biosafety in microbiological and biomedical laboratories, according to working material biohazard level.



Caution!

Incubator is equipped with an audible signal to draw attention to sensor data and warnings. Please follow the information on display. Error and alarm descriptions can be found in the **Fault Diagnostics** section.



Caution!

The incubator contains a source of UV radiation. Do not start the unit without the cover of the UV recirculator. Exposure to UV light is harmful and can cause damage to unprotected eyes and skin.

GENERAL SAFETY

- The protection provided can be ineffective if the operation of the appliance does not comply with the manufacturer's requirements.
- Save the unit from shocks and falling.
- Do not use the unit if it has visible mechanical damage.
- Store and transport the unit at ambient temperatures between -20°C and +60°C and maximum relative humidity of 80%.
- After transportation or storage and before connecting it to the electric circuit, keep the unit under room temperature for 2-3 hrs.
- Before using any cleaning or decontamination methods except those recommended by the manufacturer, check with the manufacturer that the proposed method will not damage the equipment.
- Do not make modifications in design of the unit.
- When handling hazardous substances, follow the instructions contained in the safety data sheets for the individual substances that are used and observe the relevant accident prevention regulations.
- Follow respective safety datasheet when installing and handling the CO₂ reservoir.

ELECTRICAL SAFETY

- Connect only to the mains with voltage corresponding to that on the serial number label.
- Do not plug the unit into an ungrounded power socket, and do not use an ungrounded extension lead.
- Ensure that the power plug is easily accessible during use.
- Disconnect the unit from the mains before moving.
- If liquid penetrates into the unit, disconnect it from the mains and have it checked by a repair and maintenance technician.
- Do not operate the unit in premises where condensation can form. Operating conditions of the unit are defined in the **Specifications** section.

DURING OPERATION

- Do not operate the unit in environments with aggressive or explosive chemical mixtures. Please contact manufacturer for possible operation of the unit in specific atmospheres.
- Do not operate the unit if it is faulty or has been installed incorrectly.
- Do not use outside laboratory rooms.

BIOLOGICAL SAFETY

- The user is responsible to carry out appropriate decontamination if hazardous material spills on or penetrates into the equipment.
- The user is responsible for decontaminate the unit before its decommissioning and utilization.

3. General information

S-Bt Smart BioTherm is designed for work in the areas of cell biology (operations with animal cell cultures and tissues), molecular biology (DNA/RNA reaction analysis, hybridization reactions), biotechnology (synthesis of target proteins and other molecules) and immunology (synthesis of antibodies and other proteins of immune system).

Unit provides a six-sided heating: the heating elements are located on the walls and on the door, thus providing excellent uniform temperature distribution, regardless of external factors, such as ambient temperature and positioning of the device.

Built-in infrared CO₂ sensor allows accurate control of the CO₂ level. The sensor makes measurement non-sensitive to changes in temperature and humidity inside the incubator.

The chamber is made of stainless steel with smoothed seams to minimize contamination and to facilitate cleaning.

S-Bt is equipped with a UV air recirculation system — 1 UV lamp and a fan are mounted behind the rear wall, providing decontamination of the working volume.

A convenient access port is built in the wall of the incubator for easy output of wire sensors or devices' installed inside. The access port is heated independently to prevent formation of condensate.

Unit is equipped with error tracing and alarm systems, which significantly lower potential risks during operation.

Unit is equipped with a "black box" system that records temperature, humidity and CO₂ levels as well as statuses for door opening, UV lamp, fan and errors to the inner memory.

Bluetooth connection to PC is available.

Application areas:

- Cell biology: operations with animal cell cultures and tissues
- Molecular biology: DNA/RNA reaction analysis, hybridization reactions
- Biotechnology: synthesis of target proteins and other molecules
- Immunology: synthesis of antibodies and other proteins of immune system

Features:

- Six-sided heating provides uniform distribution of the temperature inside the chamber
- Infrared CO₂ sensor, non-sensitive to temperature and humidity changes
- UV recirculation system for decontamination cycles
- Bluetooth data transfer to PC
- "Black box" parameter logging system
- Error tracing and alarm system
- Separately heated sealable port for chamber access for cables.

4. Getting started

- 4.1. **Unpacking.** Remove packing materials carefully and retain them for future shipment or storage of the unit. Examine the unit carefully for any damage incurred during transit. The warranty does not cover in-transit damage. Warranty covers only the units transported in the original package.



Caution! Due to the high weight of the unit, its unpacking and installing must be carried out by two persons.

- 4.2. **Complete set.** Package contents:

4.2.1. Standard set:

- **S-Bt Smart Biotherm**, Compact CO₂ Incubator 1 pce.
- Power cable 1 pce.
- Hydrophobic filter 2 pcs.
- Shelves 3 pcs.
- Shelf rack 1 pce.
- Water pan with lid..... 1 set
- Access port seal (foamed PE)..... 10 pcs.
- Calibration protocol 1 copy
- Operating manual, declaration of conformity 1 copy

4.2.2. Optional accessories:

- Bluetooth dongle and control/logging software for PCon request
- Additional shelveson request
- Incubator stacking device.....on request

4.3. **Setup.**

- Position the incubator on a stable platform that can support the weight of the incubator and materials inside the incubator. Ensure access to an appropriate mains outlet.
- Connect the power cable to the socket on the rear panel of the unit. Check that power switches and power plug are easily accessible.
- Locate the unit away from doors and windows and heating and air conditioning ducts. Drafts or direct sunshine can affect thermal processes and cause condensation.

4.4. Before starting operations for the first time.

- Attach the hydrophobic filter to inlets on the top side of the rear panel. Pay attention that “IN” marking must be facing right side when viewing the incubator from the front.
- Use 75% alcohol solution or any other decontaminating agent to clean the inner surfaces of the incubator and the water pan with lid.
- Switch on the recirculator for half an hour in an empty incubator to decontaminate air in the incubator. To switch on the UV recirculator, see **5.9.2.1**.

4.5. CO₂ tank requirements and setup.

- This incubator is designed for CO₂ gas only. Connecting any other gas can result in a hazardous condition. The incubator works with food grade CO₂ or better rated. Do not use a tank with siphon tube, the incubator can be damaged by liquid CO₂.
- A two-stage reductor installation is mandatory. Pressure in the output must not be higher than 1.0 bar. Follow gas supplier instructions on installing reducers and valves. Gas inlet on the incubator is a 3/8” barb fitting, marked Supply port. Secure the tube with appropriate clamps and check all connections for leaks. Gas flow should be set at 6 l/min.



Caution! Pressure higher than **1.0 bar** can damage the unit!

5. Operation

- 5.1. Connect the incubator to a grounded mains outlet. Turn the power switch on the rear of the incubator to position **I** (on).
- 5.2. After initialization, display (fig. 1) shows:
 - **Top line:** current date and time, relative humidity inside, UV lamp icon (when the lamp is on);
 - **Middle left:** temperature panel, current temperature in larger font, set temperature in smaller;
 - **Middle right:** CO₂ control panel, current percentage in larger font, set percentage in smaller;
 - **Bottom line:** Status bar, UV recirculator timer (when the lamp is on);
 - **Bottom:** six buttons, Menu, t°C □, t°C □, CO₂ □, CO₂ □, Lock.
- 5.3. **Installing shelves.** Open the front door and the inner glass door. Position the shelves according to your specification.
- 5.4. **Humidity delivery.** Pull out the water pan located on the bottom of the inner camera and fill with distilled water (~80% of volume). With the set temperature of +37°C, incubator reaches 90% of relative humidity in 8-12 hours.



Note. When operating the incubator at 90% of relative humidity for longer than 48 hours, humidity sensor values can have a measurement error.

- 5.5. **Using access port.** In order to use the access port, unscrew the cap of the access port located on the right side of the incubator. Insert necessary cable through the port and into the supplied PE seal. Install the seal into the access port. The access port is individually heated to compensate for temperature loss and condensate formation.
- 5.6. **Setting temperature.** Using t°C (and t°C (buttons, set the necessary temperature.
- 5.7. **Setting CO₂ levels.** Using CO₂ (and CO₂ (buttons, set the necessary level of CO₂.



Attention! Please make sure that the CO₂ tank is attached correctly, see 4.4.

Note. After reaching temperatures higher than 50°C, CO₂ level measurement accuracy does not conform to specifications.

- 5.8. **Locking the buttons.** **Lock** button locks the use of all the buttons under the display until **Lock** button is pressed again.
- 5.9. **Incubator menu** (fig. 2). **Menu** button opens incubator's menu. Use **Down** and **Up** buttons to navigate and **Enter** button to select. While browsing in the menu, select the topmost **Quit** option in order to return to the previous level. Option **GetID** shows the serial ID and name of the incubator.
 - 5.9.1. **Timer** (fig. 3). In this submenu user can set UV decontamination timer and Auto UV timer.
 - 5.9.1.1 **UV Decontamination Timer.** Timer parameters are set in HH:MM format. After setting the timer, UV lamp automatically switches on, main working screen displays an UV indicator (fig. 4, top right). After set time has passed, the UV lamp automatically switches off. A timer is seen on the main working screen (fig. 4, bottom right). To manually switch the lamp off, select the **Turn Off UV** option from the submenu.

5.9.1.2 **Auto UV Timer.** Each time after closing the door, UV lamp automatically switches on. After time set under this menu option has passed or the door was opened, the UV lamp automatically switches off.



Note. A turned on UV lamp can rise the temperature above the set point: the longer UV lamp stays on, the faster temperature jumps above the set point. Use this feature at your own discretion.



Attention! UV recirculation should be used for decontamination cycle while setting up and after operation, see **9.3**.



Note. In case of manual UV lamp switch off, timer continues working despite the UV lamp is off.

5.9.2. **Date & Time** (fig. 5). To set date and time in this submenu, press **Enter** button to select the parameter, then **Down** and **Up** buttons to change the value and **Enter** button to confirm changes.

5.9.3. **Service** (fig. 6). This submenu has available options **Current Errors** and **Settings**.

5.9.3.1 **Current Errors** (fig. 7). This option allows user to view and reset the list of active errors. See **6.3**, for a list of possible errors.

5.9.3.2 **Settings** (fig. 8). User can access the **Alarm Settings** and **Auto Lock Delay** options.

- **Alarm Settings** (fig. 9). User can set the alarm settings based on values of temperature, CO₂ level, and relative humidity. All alarms are working on the following principle, temperature taken as an example:

If $T_{act} < T_{thr.low}$ or $T_{act} > T_{thr.high}$ for t_{delay} minutes, then an alarm will be triggered.

Where T_{act} is the actual temperature inside the incubator, $T_{thr.low}$ is the lower threshold limit value, $T_{thr.high}$ is the higher threshold limit value and t_{delay} is the time delay in minutes. Time delay is used in order to avoid false triggering of the alarms. CO₂ level and relative humidity alarms are operated using the same principle.

- **Auto Lock Delay** (fig. 10). After being idle for several minutes, the incubator locks the buttons (except the **Lock** button). This timer allows changing the idle time.

5.9.4. **Active Alarms** (fig. 11). This option allows user to view and reset the list of active alarms. See **6.5**, for a list of possible alarms.

5.9.5. **Data Logger** (fig. 12). Data logger features following options: View Plot T(t), View Plot CO₂%(t), View Plot RH%(t), Clear log, Logger on/off.

5.9.5.1 All **View Plot** options use following interface. Figure 13 shows the temperature plot in relation to time.

- Use **Left** and **Right** buttons to move the plot along the x axis
- Use **Up** and **Down** buttons to move the plot along the y axis.
- Use **<-xx->** button to choose the x axis navigational step. Available scales are 15 minutes, 1 hour, 1 day, 1 week and 1 month.

5.9.5.2 **Clear Log** button clears the logger's data.

5.9.5.3 **Logger On/Off** button triggers the automatic logging of the data.

5.9.5.4 **Memory write location** indicator. When the data logger uses up all allocated memory, it begins overwriting data from beginning. 100% of memory is used up in approximately 1 month.

5.10. After stabilization of temperature and CO₂ level, open the doors and load the materials in the incubator according to methodological recommendations.



Note. If the door is left open for more than a minute, a short signal is sounded every 20 seconds until the door is closed.

- 5.11. **Incubator air sampling.** Sampling can be performed through the capped opening marked as “air sample”, on the rear access panel.
- 5.12. To turn off the incubator, set the power switch into position **O** (off) and detach the mains plug from the mains outlet.
- 5.13. **Operation recommendations.**
- The incubator saves settings even when switched off.
 - During decontamination treat every visible surface and door. When working with potentially pathogenic material, use more potent decontamination method. See **9.3**.

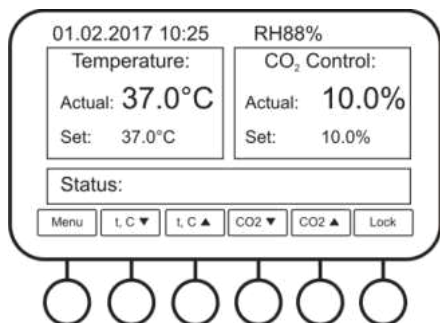

Figure 1. Working screen

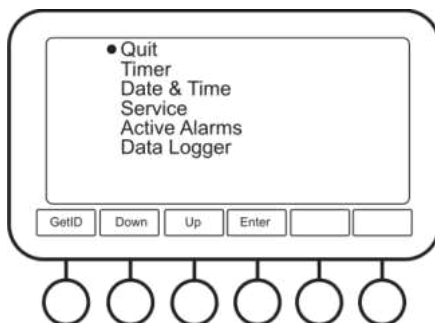

Figure 2. Menu

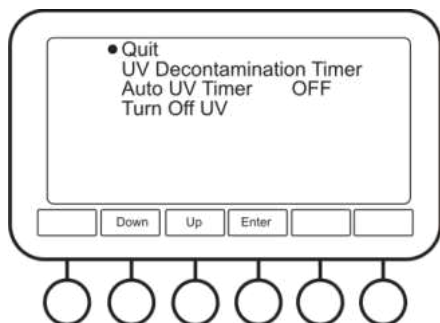

Figure 3. Timer menu

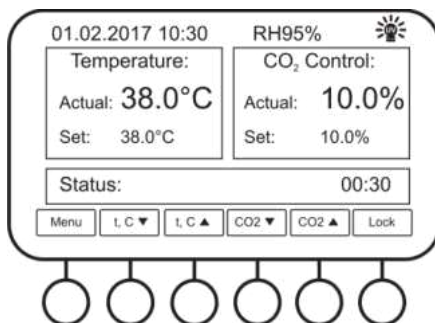

Figure 4. UV recirculator is on

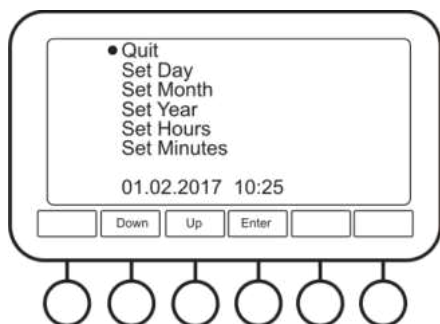

Figure 5. Date & Time menu

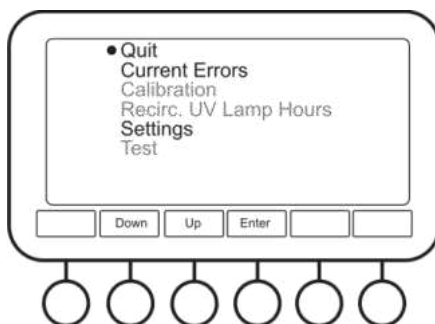

Figure 6. Service menu

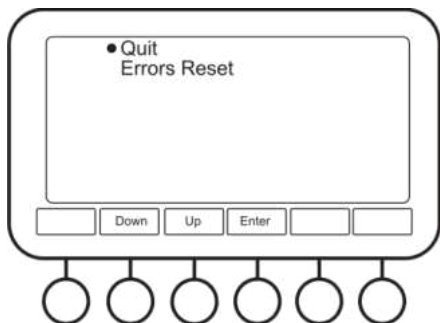

Figure 7. Current Errors menu

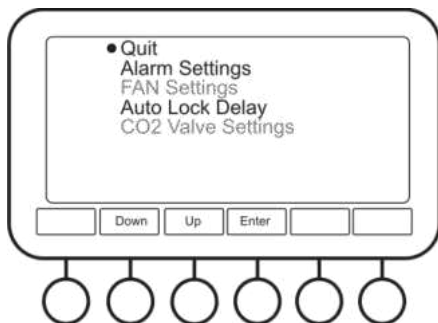

Figure 8. Settings menu

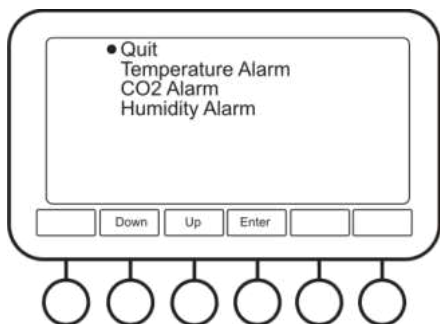

Figure 9. Alarm Settings menu

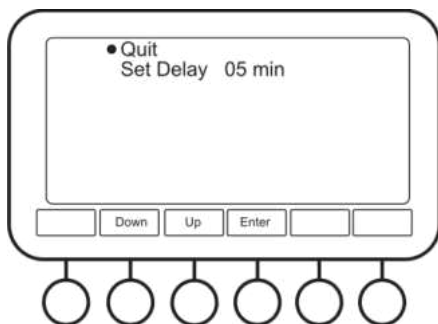

Figure 10. Auto Lock Delay menu

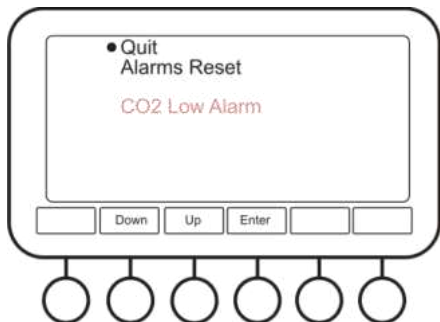

Figure 11. Active Alarms menu

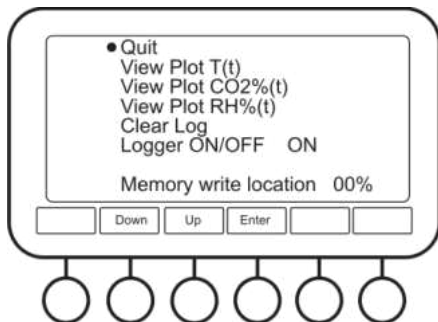

Figure 12. Data Logger

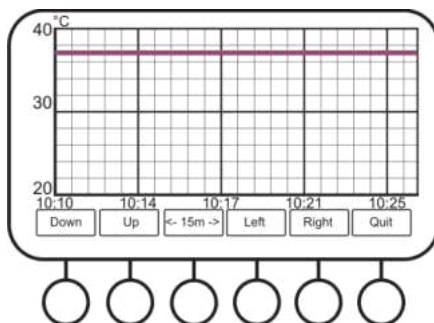

Figure 13. Temperature plot

6. Fault diagnostics

- 6.1. The incubator is equipped with an alarm and error system. Active alarms and errors are appropriately indicated on the display. Alarms and errors are followed by sound signal that can be turned off by pressing any button.
- 6.2. Error text can be found in **Menu > Service > Settings > Current Errors**, see **5.9.4**. Choose **Errors Reset** and confirm to reset the error list.
- 6.3. Error list can be found in the table below:

CO2 Sens. Err.	CO ₂ sensor error
Back	Back temperature sensor error
Bott.	Bottom temperature sensor error
Left	Left wall temperature sensor error
Right	Right wall temperature sensor error
Up	Ceiling temperature sensor error
Door	Door temperature sensor error
Chmb.	Temperature sensor in the incubator error
Perimeter T.Sens. Err.	Perimeter temperature sensor error
Recirc. Lamp Err.	UV lamp error
Communication Err.	Error connecting to power board
CO2.Sens.Comm.Err.	Error connecting to CO ₂ sensor board

- 6.4. Alarm text can be found in **Menu > Active Alarms**. Choose **Alarms Reset** and confirm to reset the alarm list.
- 6.5. Alarms list can be found in the table below. Alarms are adjustable, see **5.9.3.2**.

Temp. High Alarm	Adjustable limit is exceeded.
Temp. Low Alarm	
CO ₂ High Alarm	
CO ₂ Low Alarm	
Low Humidity	
UV Lamp Hours > 9000h	Lamp reaches end of lifetime. Consider a replacement.

7. Specifications

The unit is designed for operation in cold rooms, incubators (except CO₂ incubators) and closed laboratory rooms at ambient temperature from +4°C to +40°C in a non-condensing atmosphere and maximum relative humidity 80% for temperatures up to 31°C decreasing linearly to 50% relative humidity at 40°C.

Biosan is committed to a continuous programme of improvement and reserves the right to alter design and specifications of the equipment without additional notice.

7.1. Chamber Material.....	Stainless Steel
7.2. Temperature setting range	+25°C ... +60°C
7.3. Temperature resolution	0.1°C
7.4. Temperature stability.....	±0.1°C
7.5. Temperature uniformity @37°C.....	±0.3°C
7.6. Working volume	46 litres
7.7. Number of shelves	6 max. (3 provided)
7.8. Outer door.....	Heated, made of steel
7.9. Inner door.....	Lockable glass with UV protection film, 4 mil clear
7.10. Relative humidity.....	>90% @ 37°C
7.11. Humidity delivery.....	water pan by ventilation
7.12. CO ₂ control range ¹	0 - 20% ± 0.2%
7.13. CO ₂ sensor.....	Infrared CO ₂ sensor
7.14. Display	TFT 5"
7.15. Recirculation system	1 × 6 W UV lamp (TUV G6T5)
7.16. Recirculation system radiation type.....	UV (254 nm)
7.17. Average UV lamp life time.....	9000 h
7.18. Data transfer	Wireless (Bluetooth)
7.19. Internal data memory	1 month of nonstop logging
7.20. Access port	1 (ø 26 mm with PE seal)
7.21. Dimensions (L×W×H).....	400×410×580 mm
7.22. Work area (each shelf).....	350x350 mm
7.23. Alarms.....	Over-heating/cooling, CO ₂ leakage, Humidity loss, UV lamp error
7.24. Working voltage	230/115 V, 50/60 Hz
7.25. Weight ²	37.7 kg

¹ At temperatures below 50°C

² Accurate within ±10%

8. Ordering information

8.1. Models and versions available:

Model	Version	Description	Catalogue number
S-Bt Smart Biotherm, Compact CO ₂ Incubator	V.1AW	230 V, 50/60 Hz	BS-010425-A01
	V.1AE	120 V, 50/60 Hz	

8.2. To inquire about or order the optional accessories or the replacement parts, contact Biosan or your local Biosan representative.

8.3. Optional accessories:

Optional accessories	Catalogue number
Shelf	BS-010425-AK
Shelf rack	on request
Bluetooth dongle and software for PC	BS-010425-BK
Incubator stacking device	BS-010425-CK

8.4. Replacement parts:

Replacement parts	Catalogue number
Hydrophobic filter with tubing	BS-010425-S01
Water pan and lid	BS-010425-S02
Access port seal, foamed PE	BS-010425-S03

9. Care and maintenance

- 9.1. If the unit requires maintenance, disconnect the unit from the mains and contact Biosan or your local Biosan representative.
- 9.2. All maintenance and repair operations must be performed only by qualified and specially trained personnel.
- 9.3. Regular service schedule
 - 9.3.1. **After operation.** Switch on the recirculator running for 1 to 3 hours in an empty incubator to decontaminate air in the incubator. To switch on the UV recirculator, see **5.9.1.1**. After decontamination, slightly open the incubator doors – UV lamp has been known to produce reactive oxygen species in minor concentrations.
 - 9.3.2. **Monthly** (more frequently, if necessary):
 - Rub the inner surfaces, water pan with lid and shelves of the incubator with 75% ethanol solution or other acceptably disinfectant such as sodium hypochlorite solution, and allow them to dry.
 - After cleaning the glass door, rinse with water and dry the excess to avoid streaks and possible corrosion.
 - Remove dust with moist cloth piece from outer incubator surface, especially front screen and upper part of the incubator.
 - Visually check the hydrophobic filter (see **9.7**) and access port seal (see **9.8**) and replace if necessary.
 - Check the accuracy of CO₂ sensor system by measuring the actual CO₂ concentration with a reference CO₂ analyser.
- 9.4. Expendable materials:

Name	Description
UV lamp	TUV 6W, T5, G6
Fuse	M 3.15 A
Hydrophobic filter	CO ₂ filter
Hydrophobic filter set	Filter and tubing
Access port seal	Made from foamed PE

- 9.5. **Fuse replacement.** Disconnect incubator from the mains. Disconnect power plug from power socket. Open fuse holder. Check and replace if necessary, 230 V – M 3.15 A (type **M** - time lag: **Medium**).

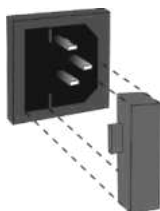

- 9.6. **UV lamp replacement.** Average lifetime of the supplied UV lamps is 9000 h. Replacement is necessary after lamp stops functioning or at the end of manufacturer specified lifetime. Only the persons who have completed special training are allowed to perform lamp replacement. UV lamp operation lifetime is checked and tracked by the incubator.
- 9.7. **Hydrophobic filter replacement.** The filter should be replaced when it becomes glazed with dirt or with sucked liquid. Maximum time of use is 30 days. We recommend replacing the filter immediately after full cycle of maintenance.
Close the CO₂ valve on the gas reservoir and turn off the unit. Remove the filter from the tubing. Insert a new filter into the socket and tighten it. Pay attention that “IN” marking must be facing right side when viewing the incubator from the front.
- 9.8. **Access port seal replacement.** To prevent possible contamination of access port seal (made from foamed polyethylene) and to ensure complete sealing of the port, the seal should be replaced after 30 days from the first operation.
- 9.9. **Calibration.** Recalibrate the unit after the date on calibration certificate. To complete the process, contact Biosan or your local Biosan representative.

10. Warranty

- 10.1. The Manufacturer guarantees the compliance of the unit with the requirements of Specifications, provided the Customer follows the operation, storage and transportation instructions.
- 10.2. The warranted service life of the unit from the date of its delivery to the Customer is 24 months. For extended warranty, see **10.5**.
- 10.3. Warranty covers only the units transported in the original package.
- 10.4. If any manufacturing defects are discovered by the Customer, an unsatisfactory equipment report shall be compiled, certified and sent to the local distributor address. To obtain the claim form, visit **Technical support** page on our website at link below.
- 10.5. Extended warranty. For **S-Bt Smart Biotherm**, the *Smart* class model, extended warranty is a paid service. Contact your local Biosan representative or our service department through the **Technical support** section on our website at the link below.
- 10.6. Description of the classes of our products is available in the **Product class description** section on our website at the link below.

Technical support



biosan.lv/en/support

Product class description



biosan.lv/classes-en

- 10.7. The following information will be required in the event that warranty or post-warranty service comes necessary. Complete the table below and retain for your records.

Model	S-Bt Smart Biotherm, Compact CO₂ Incubator
Serial number	
Date of sale	

11. Notes

12. EU Declaration of conformity

EU Declaration of Conformity

Unit type	Compact CO ₂ incubator
Models	S-Bt Smart BioTherm
Serial number	14 digits styled XXXXXYYMMZZZZ, where XXXXX is model code, YY and MM – year and month of production, ZZZZ – unit number.
Manufacturer	SIA BIOSAN Latvia, LV-1067, Riga, Ratsupites str. 7/2
Applicable Directives	EMC Directive 2014/30/EU LVD Directive 2014/35/EU RoHS2 2011/65/EU WEEE 2012/19/EU
Applicable Standards	<u>LVS EN 61326-1: 2013</u> Electrical equipment for measurement, control and laboratory use. EMC requirements. General requirements. <u>LVS EN 61010-1: 2011</u> Safety requirements for electrical equipment for measurement, control, and laboratory use. General requirements. <u>LVS EN 61010-2-010: 2015</u> Particular requirements for laboratory equipment for the heating of materials.

We declare that this product conforms to the requirements of the above Directives



Signature
Svetlana Bankovska
Managing director
15.02.2017

Date



Signature
Aleksandr Shevchik
Engineer of R&D
15.02.2017

Date

Biosan SIA

Ratsupites 7, build.2, Riga, LV-1067, Latvia
Phone: +371 67426137 Fax: +371 67428101
<http://www.biosan.lv>

Edition 1.01 – February of 2019