



REACH-IN INCUBATOR

MODEL: RI28/RI40

INSTALLATION AND OPERATIONAL MANUAL

Sheldon Manufacturing Inc. P.O. Box 627 Cornelius, Oregon 97113
EMAIL: tech@Shellab.com INTERNET: <http://www.Shellab.com/~Shellab>
1-800-322-4897 (503) 640-3000 FAX (503) 640-1366



LAB Online Exhibition



TABLE OF CONTENTS

SECTION 1.0	RECEIVING AND INSPECTION
SECTION 2.0	INSTALLATION
SECTION 3.0	GRAPHIC SYMBOLS
SECTION 4.0	CONTROL OVERVIEW
SECTION 5.0	OPERATION
SECTION 6.0	CHART RECORDER INSTALLATION
SECTION 7.0	MAINTENANCE
SECTION 8.0	TROUBLESHOOTING
SECTION 9.0	PARTS LIST
	UNIT SPECIFICATIONS
	SCHEMATICS

REV. 1/04
4861573

These units are general purpose incubators for professional, industrial or educational use where the preparation or testing of materials is done at approximately atmospheric pressure and no flammable, volatile or combustible materials are being heated. These units are not intended for hazardous or household locations or use.

RECEIVING AND INSPECTION

Your satisfaction and safety require a complete understanding of this unit. Read the instructions thoroughly and be sure all operators are given adequate training before attempting to put the unit in service. **NOTE: This equipment must be used only for its intended application; any alterations or modifications will VOID your warranty.**

- 1.1 Inspection:** The carrier, when accepting shipment, also accepts responsibility for safe delivery and is liable for loss or damage. On delivery, inspect for visible exterior damage, note and describe on the freight bill any damage found, and enter your claim on the form supplied by the carrier.
- 1.2** Inspect for concealed loss or damage on the unit itself, both interior and exterior. If necessary, the carrier will arrange for official inspection to substantiate your claim.
- 1.3 Return Shipment:** Save the shipping crate until you are sure all is well. If for any reason you must return the unit, first contact your customer representative for authorization. Supply nameplate data, including model number and serial number. Please see the manual cover for information on where to contact customer service.
- 1.4 Accessories:** Verify that all of the equipment indicated on the packing slip is included with the unit. Carefully check all packaging before discarding. These units are equipped with 6 shelves, 24 shelf clips and 4 leveling feet.

INSTALLATION

Local city, county or other ordinances may govern the use of this equipment. If you have any questions about local requirements, please contact the appropriate local agency. Installation may be performed by the end user.

Under normal circumstances this unit is intended for use indoors, at room temperatures between 5° and 40°C, at no greater than 80% Relative Humidity (at 25°C) and with a supply voltage that does not vary by more than 10%. Customer service should be contacted for operating conditions outside of these limits.

- 2.1 Power Source:** The electrical supply circuit to the incubator must conform to all national and local electrical codes. Consult the incubator's serial data plate for the voltage and ampere requirements before making connection. VOLTAGE SHOULD NOT VARY MORE THAN 10% FROM THE SERIAL PLATE RATING. This unit is intended for 50/60 Hz application. A separate circuit is recommended to prevent possible loss of product due to overloading or failure of other equipment on the same circuit.
- 2.2 Location:** When selecting a site for the incubator, consider all conditions which may affect performance, such as extreme heat from steam radiators, stoves, ovens autoclaves, etc. Avoid direct sun, fast-moving air currents, heating/cooling ducts, and high traffic areas. To ensure air circulation around the unit allow a minimum of 5cm between the unit and any walls or partitions which might obstruct free airflow.
- 2.3 Lifting / Handling:** These units are heavy and care should be taken to use appropriate lifting devices that are sufficiently rated for these loads. Units should only be lifted from their bottom surfaces. Doors, handles and knobs are not adequate for lifting or stabilization. The unit should be completely restrained from tipping during lifting or transport. All moving parts, such as shelves and trays should be removed and doors need to be positively locked in the closed position during transfer to prevent shifting and damage.
- 2.4 Leveling:** The unit must sit level and solidly. Leveling feet (supplied) are to be installed in the holes at the base of the incubator. Turn the leveling feet counterclockwise to raise level. If the unit must be moved, turn the leveling feet in all the way to prevent bending of the feet.

2.5 Cleaning: The incubator was cleaned at the factory, but not sterilized. Remove all interior parts, including shelves and shelf clips and clean all parts and the chamber with a disinfectant that is appropriate for your application. A thorough periodic cleaning is strongly recommended.

WARNING: Never clean the unit with alcohol or flammable cleaners with the unit connected to the electrical supply. Always disconnect the unit from the electrical service when cleaning and assure all volatile or flammable cleaners are evaporated and dry before reattaching the unit to the power supply.





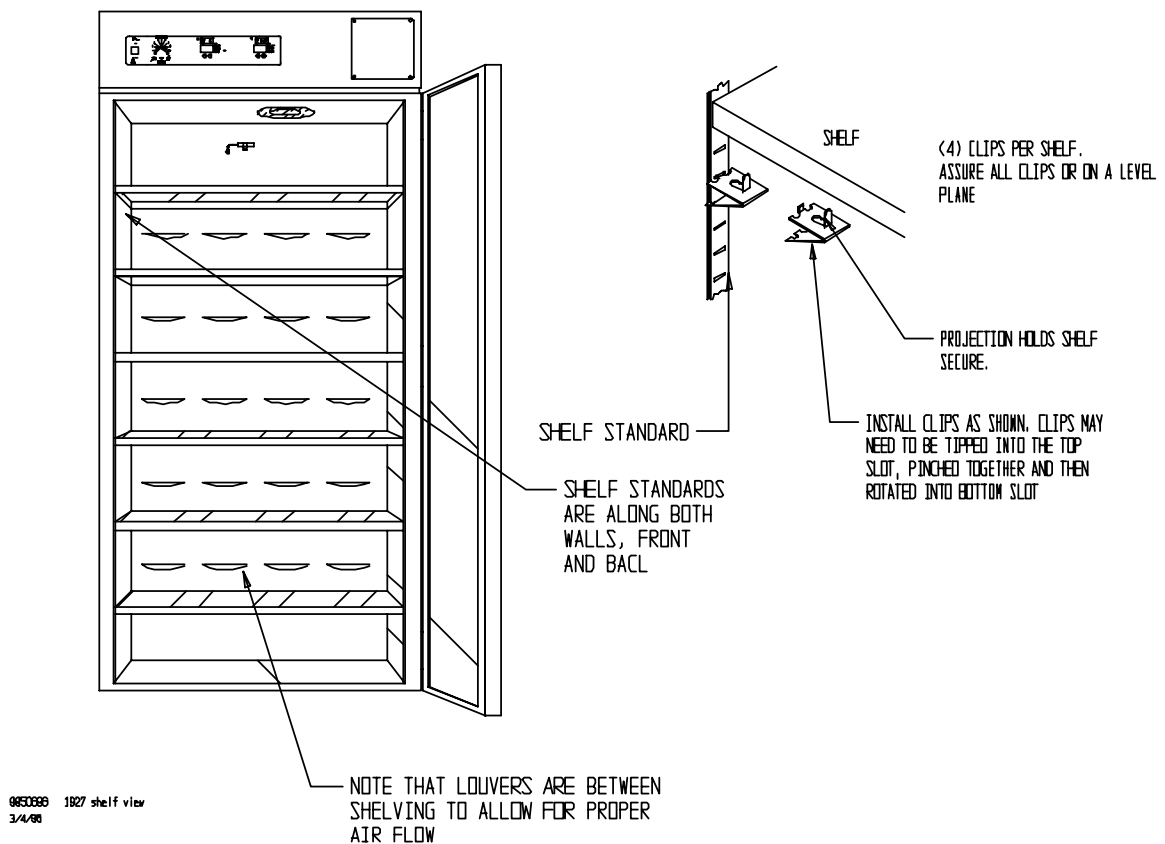

2.6 Place shelves into chamber at desired position. See **Figure 1**.

Figure 1



GRAPHIC SYMBOLS

Your incubator is provided with a display of graphic symbols on the control panel which are designed to help identify the use and function of the adjustable components.

1.  Indicates that you should consult your manual for further description and discussion of a control or user item.
2.  Indicates “**Temperature**”
3.  Indicates “**Overtemperature**”
4. $^{\circ}\text{C}$ Indicates “**Degrees Centigrade**”
5.  Indicates “**AC Power**”
6.  Indicates “**Manual Adjustment**”
7.  Indicates “**Potential Shock Hazard**” behind partition
8.  Indicates “**Earth Ground**”

CONTROL PANEL OVERVIEW

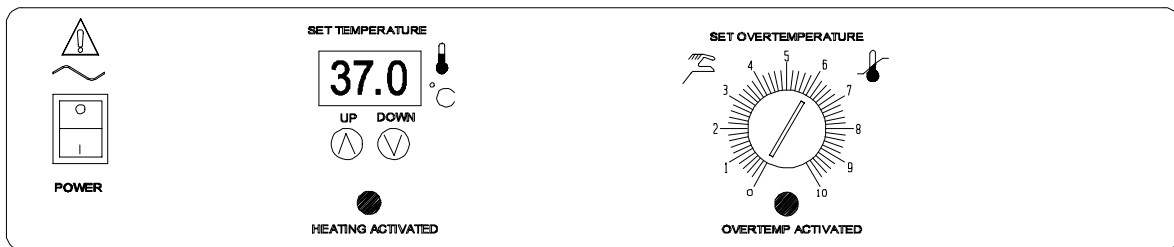

450081 4M

- 4.1 Power Switch:** The main power I/O (on/off) switch controls all power to the unit and must be in the I/ON position before any systems are operational.
- 4.2 Main Temperature Control:** The Main Temperature Control consists of the digital display and UP/DOWN arrow pads for inputting set point temperatures and calibration.
- 4.3 HEATING Lamp:** This green pilot lamp is ON when the unit is heating up to set point and is blinking when controlling temperature at set point.
- 4.4 Overtemperature Thermostat:** Marked SET OVERTEMPERATURE, the Thermostat is a completely independent control that acts as an override in the event that the Main control fails in the ON position. The Thermostat will regulate chamber temperature at approximately 1°C above the set point of the Main controller.
- 4.5 OVER TEMP Lamp:** This red pilot lamp is On when the Overtemperature Thermostat has taken control of the unit. Under normal operating conditions this lamp should never be on.
- 4.6 Circuit Breaker:** (Non-CE units) Located adjacent to the power cord, the circuit breaker is an added measure of protection against power source variations that, if tripped, can be reset by pushing in the button once the reason for the interruption has been cleared.

4.7 Fuse: (CE units) Located adjacent to the power cord in place of the circuit breaker. The fuse is an added measure of protection against power source variations, and if blown must be replaced once the source of the interruption has been cleared.

OPERATION

- 5.1 Check power supply against unit data plate, they must match. Plug service cord into the grounded electrical outlet, and turn the unit on.
- 5.2 Turn the Overtemperature Thermostat to its maximum position, clockwise, using a coin or a flat edged tool.
- 5.3 There are four (4) electrical outlets inside the chamber for use with electrical equipment not exceeding 1 amp.
- 5.4 **Operating Electrical Apparatus Inside Chamber:** Place the shaker, roller, spinner, etc. inside the incubator chamber. Plug apparatus into 1 amp outlet at rear of chamber. Be sure apparatus draws 1 amp or less (the power switch turns power on & off to outlets inside chamber).
- 5.5 **Set Main Temperature Controller:** Enter desired set point temperature. To enter set point mode on the controller, press either the Up or Down arrow pad one time. The digital display will start to blink, going from bright to dim. While blinking, the digital display is showing the set point. To change the set point, use the Up and Down arrow pads. If the arrow pads are not pressed for five (5) seconds, the display will stop blinking and will read the chamber temperature. Note that the Overtemperature Thermostat should be turned to its maximum position, (clockwise) until the unit has stabilized at desired set point temperature. Allow the incubator at least 24 hours to stabilize.
- 5.6 **Calibration:** It is recommended that calibration is done once the unit is installed in its working environment and has been stable at set point for several hours. Place a certified reference thermometer in the chamber where it can be easily viewed through the window. Be certain the thermometer is not touching any shelving. Allow the temperature to stabilize again until the thermometer reads a constant value for one hour. Compare the digital display with the reference thermometer. If there is an unacceptable difference, put the display into calibration mode by pressing both the Up and Down arrow pads at the same time for five (5) seconds until the two outside decimal points begin to flash. While the decimal points are flashing the display can be calibrated by pressing the Up or Down arrow pads until the display reads the correct value. Allow the incubator temperature to stabilize again, and recalibrate if necessary.

5.7 Set Overtemperature Thermostat: As mentioned in step 5.2, the Overtemperature Thermostat should be initially set to its maximum position, to allow the unit to stabilize. Once the incubator is stable at the desired set point, turn the Thermostat counterclockwise until the OVER TEMP light turns on. Next, turn the Thermostat clockwise just until the light turns off. Then turn the Thermostat clockwise two of the smallest divisions on its scale past the point where the light went out. This will set the Overtemperature Thermostat at approximately 1°C above Main temperature set point.

CHART RECORDER INSTALLATION

Please note that the following information is a general guide for installation. Chart recorders are available from your dealer. Before attempting installation please read the instructions provided with your chart recorder thoroughly for specific installation instructions. Note: Unplug unit from the power supply before installing the Chart Recorder.

- 6.1 Remove cover for Chart Recorder, located on the right side of control panel.
- 6.2 Remove steel plate from the back of the Chart Recorder.
- 6.3 Open the front glass door on the Chart Recorder and loosen the two screws on the face of the recorder. (Screws are on the top and bottom right of the face.)
- 6.4 Inside the unit, behind the cover plate, you will see two wires that say "Recorder Power". Cut off the butt connectors and strip the wires about 3/8 inch.
- 6.5 Put the Recorder Power wires through the hole in back of your Chart Recorder and connect the Recorder power wires to the terminal inside.
- 6.6 Run the Chart Recorder probe through the probe hole and slide into probe clips provided inside the chamber of the unit.
- 6.7 Inside the Chart Recorder you will see a piece of masking tape and a metal clip; remove these; screw face bolts back in; screw in Chart Recorder; shut the glass door on the Chart Recorder; plug unit into power supply; then turn on the unit.
- 6.8 In moving or mounting a chart, the pen arm and stylus must be raised by pressing on the tab at the uppermost end of the arm. Even if the recorder is not to be used, a fresh chart should be mounted or some sort of padding placed under the stylus to protect the sapphire tip.
- 6.9 To remove and replace a chart, unscrew the hub knob and swing it 90° clockwise, or to the 3 o'clock position. Press the upper tab on the pen arm; lift the chart forward off the hub and slide down and away. DO NOT release the pen arm, but install a new chart.

6.10 Now the pen arm may be gently released and the chart knob rotated counterclockwise back to the hub. Align the proper chart time with the chart plate index.

MAINTENANCE

NOTE: Disconnect the power cord from the power source before performing any service or maintenance on this unit.

- 7.1 Cleaning:** Clean the incubator interior and remove and clean shelves on a regular basis. Use a disinfectant that is suitable for your application. A thorough periodic cleaning is strongly recommended. Use care when cleaning the door gasket to prevent damage which could impair the positive door seal.

WARNING: Never clean the unit with alcohol or flammable cleaners with the unit connected to the electrical supply. Always disconnect the unit from the electrical service when cleaning and assure all volatile or flammable cleaners are evaporated and dry before reattaching the unit to the power supply.

- 7.2 Storage:** To prepare the unit for storage, remove all shelves and shelf clips and disconnect the power supply. Be certain that the chamber is clean and dry and the door is positively locked in the closed position. See Section 2.3, Lifting/Handling, for proper transport procedures.
- 7.3** No maintenance is required on the electrical components. If electrical or temperature problems occur, please see the Troubleshooting guide, Section 8.0, before calling for service.

TROUBLESHOOTING

FOR PERSONAL SAFETY, ALWAYS DISCONNECT THE POWER BEFORE SERVICING.

Always make a visual inspection of the incubator and control panel when troubleshooting. Look for loose or disconnected wires that may be the source of trouble.

TEMPERATURE

Temperature too high-display and reference thermometer don't match

- 1/ Controller set too high-see section 5.5.
- 2/ Controller failed on – call Customer Service.
- 3/ Wiring error – call Customer Service.

Display reads "HI" or "400"+

Probe is unplugged, is broken or wire to sensor is broken – trace wire from display to probe; move wire and watch display to see intermittent problems.

Chamber temperature spikes over set point and then settles to set point

Recalibrate – see section 5.6.

Temperature too low-display and reference thermometer don't match

- 1/ High limit set too low - see section 5.7
- 2/ Controller set too low – see section 5.5.
- 3/ Unit not recovered from door opening – wait for display to stop changing.
- 4/ Unit not recovered from power failure or being turned off – incubators will need 24 hours to warm up and stabilize.
- 5/ Element failure – see if HEATING light is on; compare current draw to data plate.
- 6/ Controller failure – confirm with front panel lights that controller is calling for heat.
- 7/ Overtemperature failure – confirm with front panel lights that Thermostat is operating correctly.
- 8/ Wiring problem – check all functions and compare wiring to owners manual – especially around any areas recently

	<p>worked on. 9/ Loose connection – call Customer Service.</p>
Display reads "LO"	<p>1/ If ambient temperature is lower than range of unit – compare set points and ambient temperature to rated specifications in section 9.0. 2/ Sensor is plugged in backwards – call Customer Service.</p>
Unit will not heat over a temperature that is below set point	<p>1/ Confirm that fan is moving and that amperage and voltage match data plate – check fan motor motion by removing top panel of the unit. 2/ Confirm that set point is set high enough –turn Thermostat all the way clockwise and see if HEATING light or OVERTEMP light comes on. 3/ Check connections to sensor. 4/ Check calibration – using independent thermometer, follow instructions in section 5.6.</p>
Unit will not heat up at all	<p>1/ Verify that controller is asking for heat by looking for HEATING light – if pilot light is not on continuously during initial start up, there is a problem with the controller. 2/ Check amperage – amperage should be virtually at maximum rated (data plate) amperage. 3/ Do all controller functions work? 4/ Is the Overtemperature set high enough? – for diagnostics, should be fully clockwise with the pilot light never on. 5/ Has the fuse/circuit breaker blown?</p>
Indicated chamber temperature unstable	<p>1/ ± 0.1 may be normal. 2/ Is fan working? – remove top panel and verify movement of cooling fan. 3/ Is ambient radically changing – either door opening or room airflow from heaters or air conditioning? – stabilize ambient conditions. 4/ Sensor miss-located, damaged or wires may be damaged - check mounts for control and Overtemperature sensors, then trace wires or tubing between sensors and controls. 5/ Calibration sensitivity – call Customer Service. 6/ Overtemperature set too low – be sure that its setting is more than 5 degrees over desired set point; check if pilot light is on continuously; turn controller knob completely clockwise to see if problem solved then follow instructions in section 5.7 for correct setting. 7/ Electrical noise – remove nearby sources of RFI including motors, arcing relays or radio transmitters.</p>

8/ Bad connection on temperature sensor or faulty sensor – check connectors for continuity and mechanical soundness while watching display for erratic behavior; check sensor and wiring for mechanical damage.
9/ Bad connections– check connectors for mechanical soundness and look for corrosion around terminals or signs of arcing or other visible deterioration.

Will not maintain set point

1/ Assure that set point is at least 5 degrees over ambient.
2/ See if ambient is fluctuating – check for adjacent open doors or HVAC duct openings, stabilize ambient conditions.

Display and reference thermometer don't match

1/ Calibration error – see section 5.6.
2/ Temperature sensor failure – evaluate if pilot light is operating correctly.
3/ Controller failure – evaluate if pilot light is operating correctly.
4/ Allow at least 24 hours to stabilize at set point temperature.
5/ Verify that reference thermometer is certified.

Can't adjust set points or calibration

1/ Turn entire unit off and on to reset.
2/ If repeatedly happens, call Customer Service.

Calibrated at one temperature, but not at another

This can be a normal condition when operating temperature varies widely. For maximum accuracy, calibration should be done at or as close to the set point temperature as possible.

MECHANICAL

Door not sealing

1/ Check physical condition of gasket.
2/ Assure that gasket is in original location.
3/ Adjust hinge blocks or twist the door.
4/ Confirm that unit has not been damaged and body is square.

Motor doesn't move

1/ If shaft spins freely: check connections to motor and check voltage to motor.
2/ If shaft rubs or is frozen, relieve binding and retest.

Motor makes noise

1/ If noise is from the motor, tap the top of motor shaft with ball peen hammer. Remove back panel to access fan motor.
2/ If the sound gets worse, tap the other end of the shaft – avoiding touching the fan blade.

- 3/ If there is no change, call Customer Service.
- 4/ If noise is from shaft or fan blade, realign shaft.

OTHER

Controller on at all times - "locked-up"

- 1/ Turn unit off and on to reset.
- 2/ If cannot change any condition on the front panel, call Customer Service.

Front panel displays are all off

Check for wire damage.

Unit or wall fuse/circuit breaker is blown

- 1/ Check wall power source.
- 2/ Compare current draw and compare to specs on data plate.
- 3/ See what other loads are on the wall circuit.

Unit will not turn on

- 1/ Check wall power source.
- 2/ Check fuse/circuit breaker on unit or in wall.
- 3/ See if unit is on, e.g., fan or heater, and just controller is off.
- 4/ Check all wiring connections, especially around the on/off switch.

Unit is smoking – Out of box

This is not an uncommon occurrence when first operating new units. Put unit under vent and run at full power for one hour. – smoking is normal during first cycle to temperature.

Contamination in chamber

- 1/ See cleaning procedure in section 2.5.
- 2/ Develop and follow standard operating procedure for specific application; include definition of cleaning technique and maintenance schedule.

If following these troubleshooting suggestions does not solve the problem call your customer service representative for assistance. Please see the manual cover for information on where to contact customer service.

PARTS LIST

Description	115V	220V
Blower Motor	4880512	4880512
Blower Wheel	100056	100056
Circuit Breaker	1100505	1100505
Cooling Fan, Control Panel	210002	210001
Cord Set	100014	101990
Cord set, European	NA	X1000778
EMI Filter, CE units only	NA	2800502
Heating Element, RI28	210024	120071
Heating Element, RI40	120074	X1000510
Overtemperature Thermostat	9560515	9560515
I/O (On/Off) Power Switch	X1000124	X1000124
Moisture Proof Plug	1650530	1650530
Main Control w/Sensing Probe	1750582	1750583
Outlet, Interior	1650531	1650531
Pilot Light, Green	200021	200021
Pilot Light, Red	200020	200020
Shelf, RI28	5400500	5400500
Shelf, RI40	5401146	5401146

UNIT SPECIFICATIONS

Weight	Shipping	Net
RI28	610 lbs.	500 lbs.
RI40	730 lbs.	850 lbs.

Dimensions	Exterior WxDxH	Interior WxDxH
RI28	37x33x75	30.5x26x62
RI40	41x34x87	35x26x76.5

Capacity	
RI28	28 Cubic Feet
RI40	40 Cubic Feet

Temperature	Range	Uniformity	Sensitivity
RI28	Amb. +7 to 70°C	± .5°C @ 37°	± .05°C
RI40	Amb. +7 to 70°C	± .5°C @ 37°	± .05°C

WIRE DIAGRAM

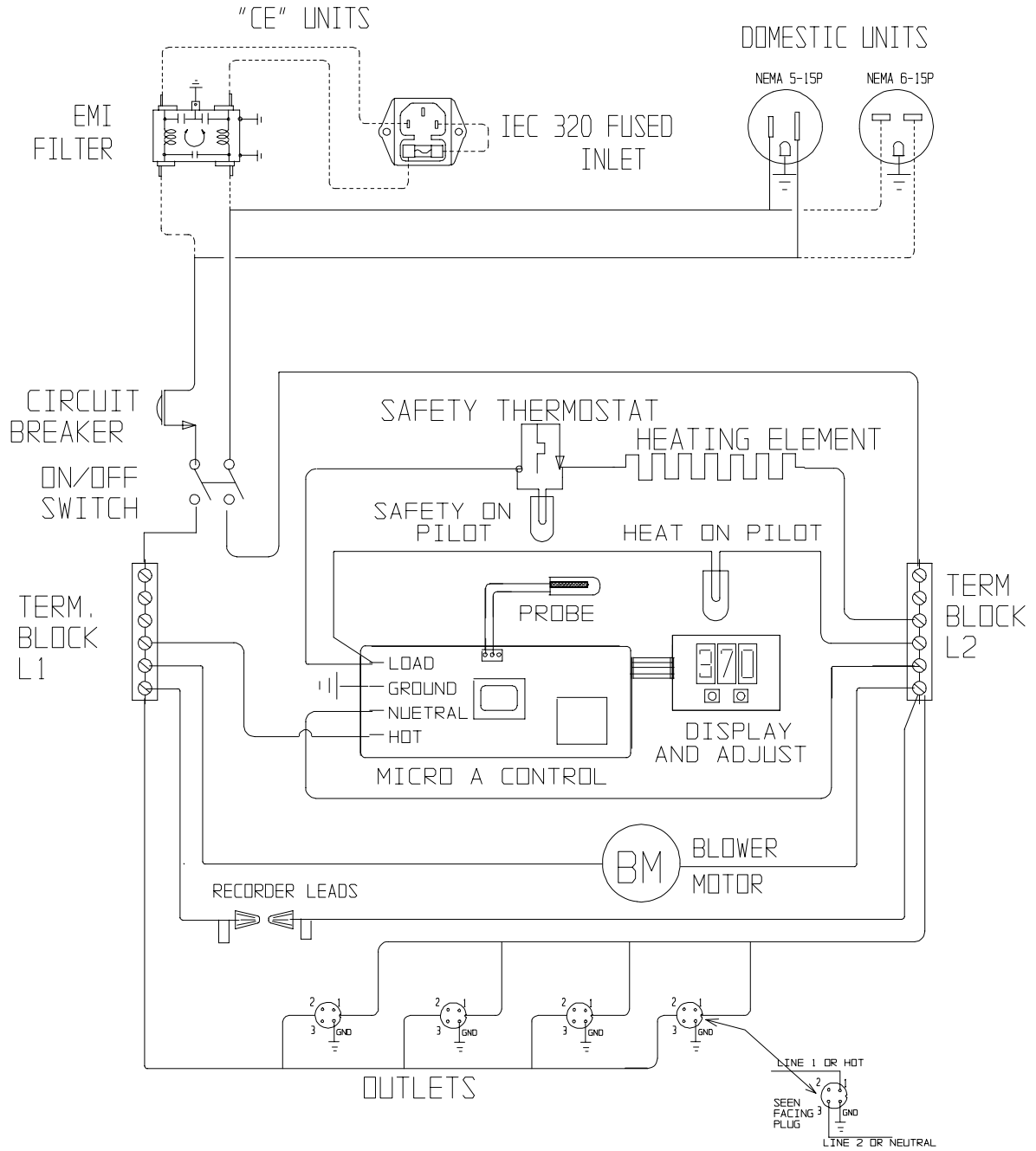

9850503