

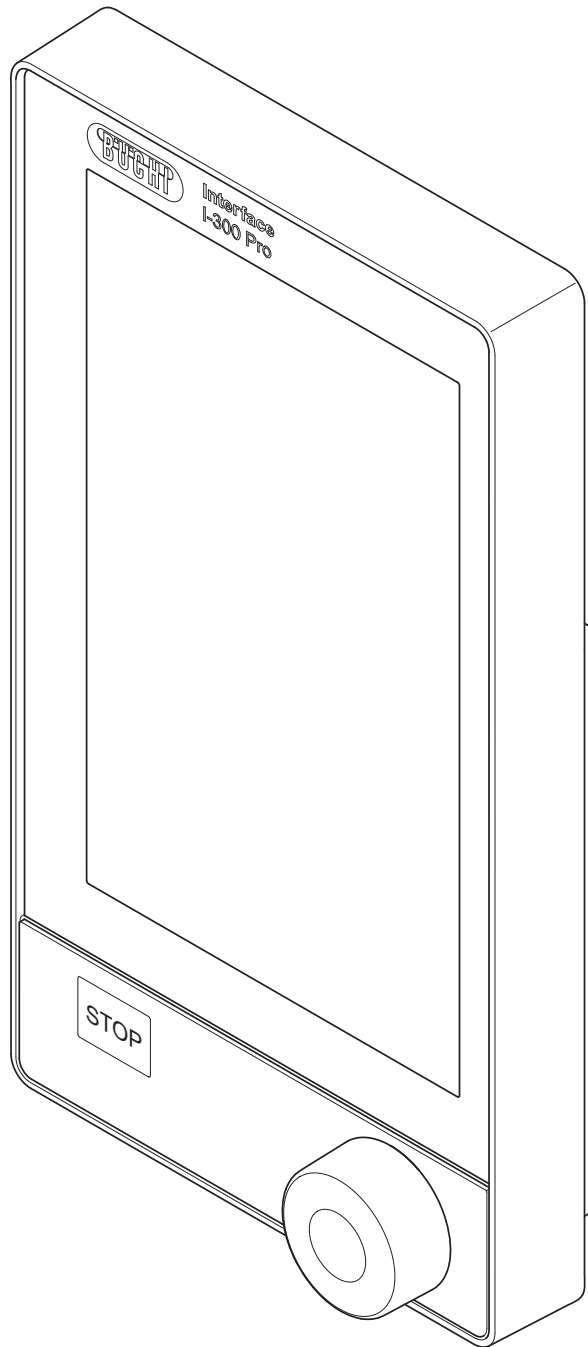

Interface I-300 Pro Operation Manual





LAB Online Exhibition



Imprint

Product Identification:
Operation Manual (Original) Interface I-300 Pro
11593781

Publication date: 10.2016

BÜCHI Labortechnik AG
Meierseggrasse 40
Postfach
CH-9230 Flawil 1

E-Mail: quality@buchi.com

BÜCHI reserves the right to make changes to the manual as deemed necessary in the light of experience, especially with respect to structure, illustrations and technical detail.

This manual is copyrighted. Information from it may not be reproduced, distributed, or used for competitive purposes, nor made available to third parties. The manufacture of any component with the aid of this manual without prior written agreement is also prohibited.

Contents

1	About this document.....	6
1.1	Warning notices in this document.....	6
1.2	Symbols.....	6
1.2.1	Warning symbols.....	6
1.2.2	Mandatory directive symbols.....	7
1.2.3	Other symbols.....	7
1.3	Available languages.....	7
1.4	Trademarks.....	7
2	Safety.....	8
2.1	Intended use.....	8
2.2	Use other than that intended.....	8
2.3	Staff qualification.....	8
2.4	Residual risks.....	9
2.4.1	Faults during operation.....	9
2.5	Personal protective equipment.....	9
2.6	Modifications.....	9
3	Product description.....	10
3.1	Description of function.....	10
3.2	Control of the R-300 with and without interface unit/VacuBox.....	10
3.3	Control of R-300 and R-220 Pro.....	11
3.3.1	Parameter display with R-300 and R-220 Pro.....	12
3.3.2	Operating modes for R-300 and R-220 Pro.....	12
3.4	Configuration.....	13
3.4.1	Front view.....	13
3.4.2	Rear view.....	14
3.4.3	VacuBox (connections).....	15
3.4.4	LegacyBox (connections).....	16
3.4.5	Display.....	18
3.4.6	Type plate.....	19
3.5	Navigating through the menu system.....	20
3.5.1	Main menu.....	20
3.5.2	Operating modes.....	21
3.5.3	Configuration.....	23
3.5.4	Solvent library/Own solvent library.....	27
3.6	Specifications supplied.....	28
3.6.1	Interface I-300 Pro.....	28
3.6.2	VacuBox.....	28
3.6.3	LegacyBox.....	28
3.7	Technical data.....	29
3.7.1	Interface I-300 Pro.....	29
3.7.2	VacuBox.....	29
3.7.3	LegacyBox.....	30
3.7.4	Ambient conditions.....	30
3.7.5	Materials.....	30
4	Transport and storage.....	31
4.1	Transport.....	31
4.2	Storage.....	31

5	Installation.....	32
5.1	Fitting the Interface I-300/I-300 Pro.....	32
5.1.1	Mounting interface on Rotavapor R-300.....	32
5.1.2	Fitting interface unit on Vacuum Pump V-300.....	34
5.1.3	Mounting interface unit on Rotavapor R-220 Pro.....	35
5.1.4	Mounting interface unit on laboratory stand (optional accessory).....	36
5.1.5	Mounting interface unit on a wall bracket (optional accessory).....	36
5.2	Connecting the Interface I-300/I-300 Pro.....	38
5.2.1	Connecting communication cables to interface unit.....	38
5.2.2	Overview: setting up communication connections.....	39
5.2.3	Overview: setting up coolant tubing connections.....	40
5.2.4	Overview: setting up vacuum tubing connections.....	41
5.3	Connecting AutoDest sensor to vapor temperature sensor (optional accessory).....	42
5.4	Connecting foam sensor (optional accessory).....	44
5.5	Connecting valve unit for external vacuum.....	46
5.6	Operating I-300 and I-300 Pro in parallel.....	46
6	Operation.....	47
6.1	Navigating the menu.....	47
6.1.1	Selecting menu items.....	47
6.1.2	Entering parameter settings.....	50
6.1.3	Changing settings.....	52
6.2	Performing distillation.....	54
6.2.1	Overview: typical distillation sequence.....	55
6.2.2	Basic functions.....	56
6.2.3	Controlling lift position via the interface unit.....	58
6.2.4	Performing manual distillation.....	59
6.2.5	Performing timer-controlled distillation.....	63
6.2.6	Drying the system after distillation ("Continuous pumping").....	69
6.2.7	Performing automatic distillation.....	72
6.2.8	Drying the product.....	75
6.2.9	Methods.....	78
6.3	Displaying reading graphs.....	84
6.4	Recording process data.....	85
6.4.1	Inserting an SD card.....	86
6.4.2	Activating recording.....	87
6.5	Solvent library.....	88
6.5.1	Using the solvent library.....	88
6.5.2	Creating your own solvent library.....	92
6.6	Activating eco mode.....	93
6.7	Setting hysteresis.....	94
6.8	Creating favorites.....	95

7	Mobile connection	97
7.1	Setting up BUCHI Connect Solution	97
7.2	Components of the BUCHI Connect Solution	98
7.3	Requirements for local network settings	98
7.4	Connecting interface unit to the LAN	99
7.5	Handling data	99
7.6	Enabling interface unit for access to BUCHI Cloud	101
7.7	Assigning IP addresses	102
7.8	Downloading and installing the BUCHI Rotavapor app	103
7.9	Viewing the QR code	104
7.10	Generating a password	105
7.11	Connecting to the distillation system with the BUCHI Rotavapor app	106
7.12	Scanning the QR code with your smartphone	107
7.13	Activating push notifications	108
7.14	Remotely retrieving process data	109
7.15	Optional function: setting up a local server	110
8	Cleaning and servicing	112
8.1	Cleaning the casing/display	112
8.2	Performing a leak test	112
8.3	Fitting GL14 cap nut with tube seal	114
8.4	Checking seals	115
8.5	Calibrating AutoDest sensor	115
8.6	Calibrating the pressure sensor	116
	8.6.1 Offset calibration	118
	8.6.2 Simple calibration	119
	8.6.3 Loading factory calibration	120
9	Help with faults	121
9.1	Faults, possible causes and remedies	121
9.2	Error messages	122
9.3	Customer service	122
10	Taking out of service and disposal	123
10.1	Taking out of service	123
10.2	Disposal	123
11	Appendix	124
11.1	Solvent table	124
11.2	Spare parts and accessories	126
	11.2.1 Accessories	126
	11.2.2 Wear parts	127
	11.2.3 Spare parts	128
11.3	Health and safety approval	129
11.4	Health and safety	130

1 About this document

These operating instructions describe the Interface I-300 Pro at the time supplied. They are an integral part of the product and contain important information that is necessary for safe operation and maintenance.

These operating instructions apply to all variants of the Interface I-300 Pro and are intended primarily for laboratory staff.

- ▶ To ensure safe and trouble-free operation, read these operating instructions before starting up the device and follow the guidance they contain.
- ▶ Keep the operating instructions somewhere near to the device.
- ▶ Pass on the operating instructions to any subsequent owner or user.

BÜCHI Labortechnik AG accepts no liability whatsoever for any faults or damage that result from the failure to follow these operating instructions.

- ▶ If you still have any questions after reading these operating instructions, please contact BÜCHI Labortechnik AG Customer Service. Contact details for your local agents can be found on the Internet at <http://www.buchi.com>.

1.1 Warning notices in this document









Warning notices warn you of dangers that can occur when handling the device. There are four danger levels, each identifiable by the signal word used.





Signal word	Meaning
DANGER	Indicates a danger with a high level of risk which could result in death or serious injury if not prevented.
WARNING	Indicates a danger with a medium level of risk which could result in death or serious injury if not prevented.
CAUTION	Indicates a danger with a low level of risk which could result in minor or medium-severity injury if not prevented.
IMPORTANT	Indicates a danger that could result in damage to property.

1.2 Symbols





The following symbols may be displayed in this instruction manual or on the device:

1.2.1 Warning symbols

Symbol	Meaning	Symbol	Meaning
	General warning		Corrosive substance
	Dangerous electrical voltage		Flammable substance
	Biological hazard		Potentially explosive atmosphere
	Breakable items		Dangerous gases

Symbol	Meaning	Symbol	Meaning
	Hot surface		Health-harming or irritant substances
	Risk of hand injury		Strong magnetism

1.2.2 Mandatory directive symbols

Symbol	Meaning	Symbol	Meaning
	Wear safety goggles		Wear protective clothing
	Wear protective gloves		Heavy load, do not lift without assistance

1.2.3 Other symbols



NOTE

This symbol draws attention to useful and important information.

- This character draws attention to a requirement that must be met before the instructions below are carried out.
- This character indicates an instruction that must be carried out by the user.
- This character indicates the result of a correctly carried out instruction.

1.3 Available languages

These operating instructions were originally produced in German and have been translated into several other languages. The translations are available on the enclosed CD or can be obtained as a PDF file via <http://www.buchi.com>.

1.4 Trademarks

Product names and registered or unregistered trademarks that are used in this instruction manual are used only for identification and remain the property of the owner in each case.

For example, Rotavapor® is a registered trademark of BÜCHI Labortechnik AG.

2 Safety

2.1 Intended use

The Interface I-300 Pro is intended for indicating vacuum within an operating range of 0 mbar to ambient atmospheric pressure. The measurement and regulation of the vacuum is performed by means of a VacuBox. The Interface I-300 Pro has been designed and built as an item of laboratory equipment and can be used in conjunction with the following devices:

- Distillation apparatus, especially rotary evaporators
- Vacuum-drying cabinets
- Vacuum pumps
- Recirculating chiller

2.2 Use other than that intended

Use of any kind other than that described in the section Intended use and any application that does not comply with the technical specifications (see Chapter 3.7 "Technical data", page 29) constitutes use other than that intended.

In particular, the following applications are not permissible:

- Use of the device in areas that require apparatus that is safe to use in potentially explosive atmospheres.
- Use as a calibration device for other equipment.
- Operation at pressures above atmospheric

Damage or hazards attributable to use of the product other than as intended are entirely at the risk of the user alone.

2.3 Staff qualification

Unqualified persons are unable to identify risks and are therefore exposed to greater dangers.

The device may only be operated by suitably qualified laboratory staff.

These operating instructions are aimed at the following target groups:

Users

Users are persons that meet the following criteria:

- They have been instructed in the use of the device.
- They are familiar with the contents of these operating instructions and the applicable safety regulations and apply them.
- They are able on the basis of their training or professional experience to assess the risks associated with the use of the device.

Operator

The operator (generally the laboratory manager) is responsible for the following aspects:

- The device must be correctly installed, commissioned, operated and serviced.
- Only suitably qualified staff may be assigned the task of performing the operations described in these operating instructions.
- The staff must comply with the locally applicable requirements and regulations for safe and hazard-conscious working practices.
- Safety-related incidents that occur while using the device should be reported to the manufacturer (quality@buchicom).

BUCHI service technicians

Service technicians authorized by BUCHI have attended special training courses and are authorized by BÜCHI Labortechnik AG to carry out special servicing and repair measures.

2.4 Residual risks

The device has been developed and manufactured using the latest technological advances. Nevertheless, risks to persons, property or the environment can arise if the device is used incorrectly.

Appropriate warnings in this manual serve to alert the user to these residual dangers.

2.4.1 Faults during operation

If a device is damaged, sharp edges, moving parts or exposed electrical wires can cause injuries.

- ▶ Regularly check device for visible damage.
- ▶ If faults occur, switch off the device immediately, unplug the power cord and inform the operator.
- ▶ Do not continue to use devices that are damaged.

2.5 Personal protective equipment

Depending on the application, hazards due to heat and/or corrosive chemicals may arise.

- ▶ Always wear appropriate personal protective equipment such as safety goggles, protective clothing and gloves.
- ▶ Make sure that the personal protective equipment meets the requirements of the safety data sheets for all chemicals used.

2.6 Modifications

Unauthorized modifications may impair safety and lead to accidents.

- ▶ Use only genuine BUCHI accessories, spare parts and consumables.
- ▶ Technical modifications to the device or accessories should only be carried out with the prior written approval of BÜCHI Labortechnik AG and only by authorized BUCHI technicians.

BUCHI accepts no liability whatsoever for damage arising as a result of unauthorized modifications.

3 Product description

3.1 Description of function

The Interface I-300 Pro is designed for indicating, adjusting and controlling the complete distillation system. The Interface I-300 Pro settings enable precise specification of the individual process parameters. For example:

- Rotation speed of the evaporating flask
- Specified temperature of the heating bath
- Specified temperature of the coolant
- Specified vacuum pressure
- Duration of the distillation process

The pressure is measured and regulated by the associated VacuBox. Measurement is independent of the solvent used.

3.2 Control of the R-300 with and without interface unit/VacuBox

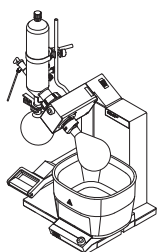

The Rotavapor R-300 can be operated with or without an Interface I-300 Pro. Without an Interface I-300 Pro, operation is performed individually on each device.

	Without interface unit/VacuBox	With interface unit/VacuBox
Vacuum pump delivery	<ul style="list-style-type: none"> • No vacuum control 	<ul style="list-style-type: none"> • Current system pressure shown on display (home screen) • Setting and display of specified vacuum
Evaporating flask rotation speed	<ul style="list-style-type: none"> • Rotation speed set using control knob • Current rotation speed not shown on heating bath base 	<ul style="list-style-type: none"> • Rotation speed set using control knob • Current rotation speed shown on display (home screen) and on heating bath base
Heating bath temperature	<ul style="list-style-type: none"> • Current temperature shown on display on heating bath base • Required temperature set using control knob on heating bath base 	<ul style="list-style-type: none"> • Current and set temperature shown on display (home screen) of interface unit and on heating bath base • Required temperature set using control knob on heating bath base
Recirculating chiller temperature	<ul style="list-style-type: none"> • Current coolant temperature shown on display on device • Required temperature set using control knob on device 	<ul style="list-style-type: none"> • Current system temperature shown on display (home screen) and on device • Required temperature set using control knob on device

	Without interface unit/VacuBox	With interface unit/VacuBox
Vapor temperature	<ul style="list-style-type: none"> No display of vapor temperature possible 	<ul style="list-style-type: none"> Vapor temperature shown on display (home screen)
Lift position	<ul style="list-style-type: none"> Lift position set by means of "vertical adjustment handle" 	<ul style="list-style-type: none"> Lift position set by means of "vertical adjustment handle" Lift position set by means of "Up" and "Down" buttons on home screen *

* Only available with Interface I-300 Pro

3.3 Control of R-300 and R-220 Pro

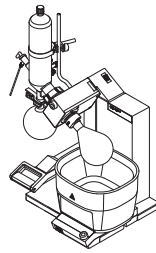

The R-300 and R-220 Pro Rotavapors can both be controlled by an Interface I-300/ I-300 Pro. However, there are a couple of particularities because of the slightly different design of the devices.

	R-300	R-220 Pro
Interface unit mounting	Option: I-300 or I-300 Pro mounted on Rotavapor arm, see Chapter 5.1.1 "Mounting interface on Rotavapor R-300", page 32.	Ready mounted: I-300 Pro mounted on device directly adjacent to internal display, see Chapter 5.1.3 "Mounting interface unit on Rotavapor R-220 Pro", page 35.
Information on display	Full display of figures and graphs on display of I-300 Pro.	Display of figures and graphs split between I-300 and R-220 Pro.
Lift control	Manual and programmed control of lift position possible, see Chapter 6.2.3 "Controlling lift position via the interface unit", page 58.	Manual adjustment of lift position possible, see Chapter 6.2.3 "Controlling lift position via the interface unit", page 58.
"Drying" mode	Drying of sample after distillation possible: "Drying" mode – manual or timer controlled, see Chapter 6.2.8 "Drying the product", page 75.	"Drying" mode not available with R-220 Pro.
Communication cable connection	See operating instructions for the Rotavapor R-300.	See operating instructions for the Rotavapor R-220 Pro.
Connections	External valves connected to VacuBox, Chapter 5.5 "Connecting valve unit for external vacuum", page 46.	External valves connected directly to R-220 Pro.

3.3.1 Parameter display with R-300 and R-220 Pro



The parameters for the current distillation process are shown on the home screen of the Interface I-300 Pro. Depending on which Rotavapor the interface unit is connected to, different parameters may be shown. Below is a comparison of the R-300 and R-220 Pro Rotavapors:

Parameter	Information	R-300	R-220 Pro
Vacuum	<ul style="list-style-type: none"> Current system pressure Desired system pressure 	✓	✓
Rotation	<ul style="list-style-type: none"> Current rotation speed Desired rotation speed 	✓	(✓)*
Heating bath	<ul style="list-style-type: none"> Current heating bath temperature Desired heating bath temperature 	✓	(✓)*
Recirculating chiller	<ul style="list-style-type: none"> Current system temperature Desired system temperature 	✓	✓
Vapor	<ul style="list-style-type: none"> Current vapor temperature 	✓	(✓)*
Lift	<ul style="list-style-type: none"> Raise lift Lower lift 	✓	(✓)**

* With the Rotavapor R-220 Pro these parameters are not shown if the reduced display option (display split between internal Rotavapor display and interface unit) is activated.

** Lift position not displayed with R-220 Pro.

3.3.2 Operating modes for R-300 and R-220 Pro

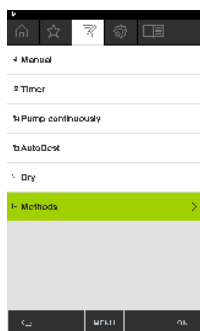

Operating modes	Purpose	R-300	R-220 Pro
Manual	Carrying out distillation with manually set parameters	✓	✓

Operating modes	Purpose	R-300	R-220 Pro
Timer	Carrying out a distillation process with manually set parameters which is to be stopped after a set time has elapsed	✓	✓
Continuous pumping	Drying the system after distillation	✓	✓
AutoDest (automatic mode sensor)	Carrying out automatic single or multi-stage distillation with specified settings for the vacuum continuously adjusted by the system	✓	✓
Drying	Post-drying of contents of evaporating flask. (This feature is only available in conjunction with the Rotavapor R-300.)	✓	∅
Methods	Carrying out distillation according to a sequence of programmed steps with defined times and parameters.	✓	✓

For a detailed description of the operating modes see Chapter 3.5.2 "Operating modes", page 21.

3.4 Configuration

3.4.1 Front view

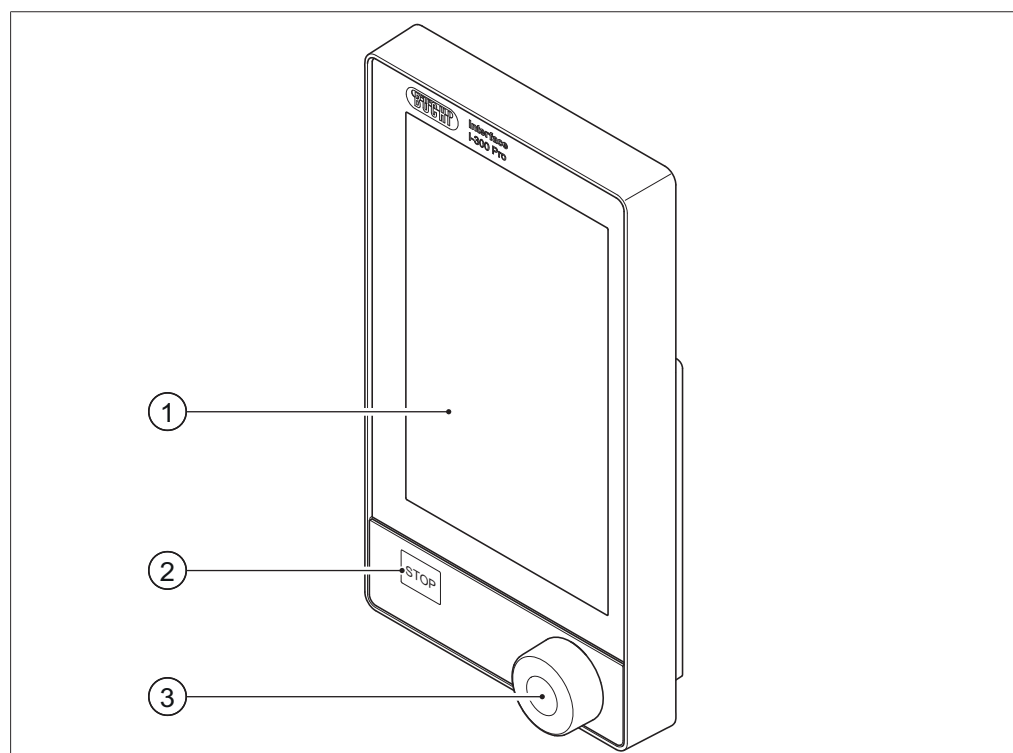

Fig. 1: Front view of Interface I-300 Pro

- | | |
|--------------------------------|----------------------|
| 1 Touch-screen display | 3 Navigation control |
| 2 STOP button (emergency stop) | |

3.4.2 Rear view

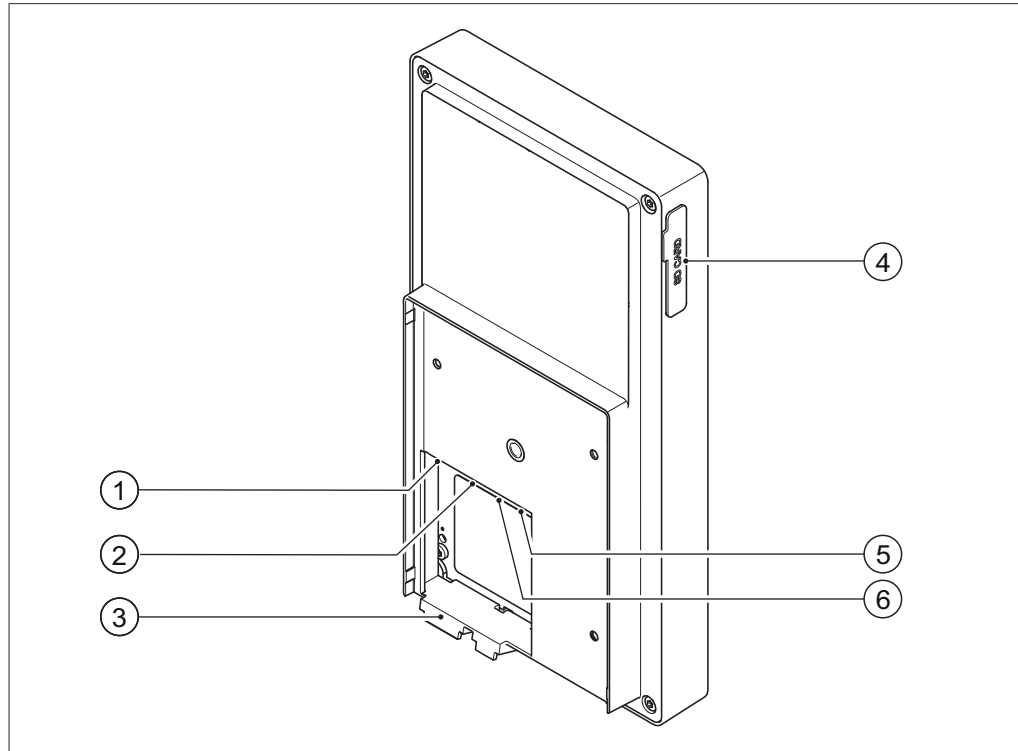

Fig. 2: Rear view of Interface I-300 Pro

- | | |
|---|-----------------------------|
| 1 LAN port | 4 Slot for BUCHI SD card |
| 2 BUCHI standard communication port (COM) | 5 USB connection (not used) |
| 3 Locating lug for bracket | 6 MicroSD card (not used) |

3.4.3 VacuBox (connections)

Other BUCHI laboratory equipment is connected to the Interface I-300 Pro in series together with the VacuBox. The individual devices are connected to one another via the standard BUCHI communication port (7). See Chapter 5.2.2 "Overview: setting up communication connections", page 39.

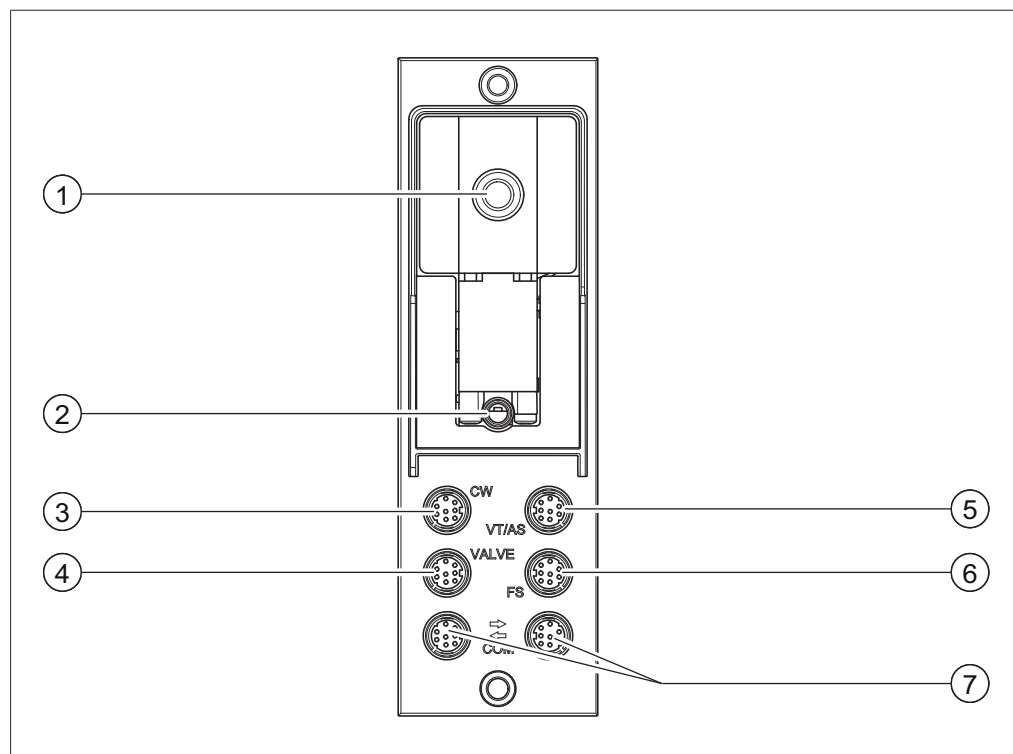

Fig. 3: Connections on the VacuBox

- | | |
|---|--|
| 1 Vacuum connection | 5 Connection for vapor temperature/AutoDest sensor (VT/AS) |
| 2 Venting valve/inert gas connection (optional) | 6 Foam sensor connection (FS) |
| 3 Water coolant valve connection (CW) | 7 Standard BUCHI communication port (COM) |
| 4 Connection for valve unit or straight-way valve (VALVE) | |



NOTE

Connecting VacuBox with R-220 Pro:

If the Interface I-300 Pro and the VacuBox are operated in the Rotavapor R-220 Pro system, the following points should be noted: The external valves must always be connected to the Rotavapor R-220 Pro even if there is an alternative connection on the VacuBox.

3.4.4 LegacyBox (connections)

Connection of a LegacyBox is required whenever legacy BUCHI laboratory equipment is to be controlled via the Interface I-300 Pro. The LegacyBox is connected to the distillation system using a standard BUCHI communication cable and has other connection options such as an RS-485 communication port. There is also the option of incorporating pumps of other makes in the Rotavapor system and controlling them via the interface. In that case, the pump requires a 0 – 10 V input.

The LegacyBox is fixed to a Rotavapor R-300 or a laboratory stand clamp.

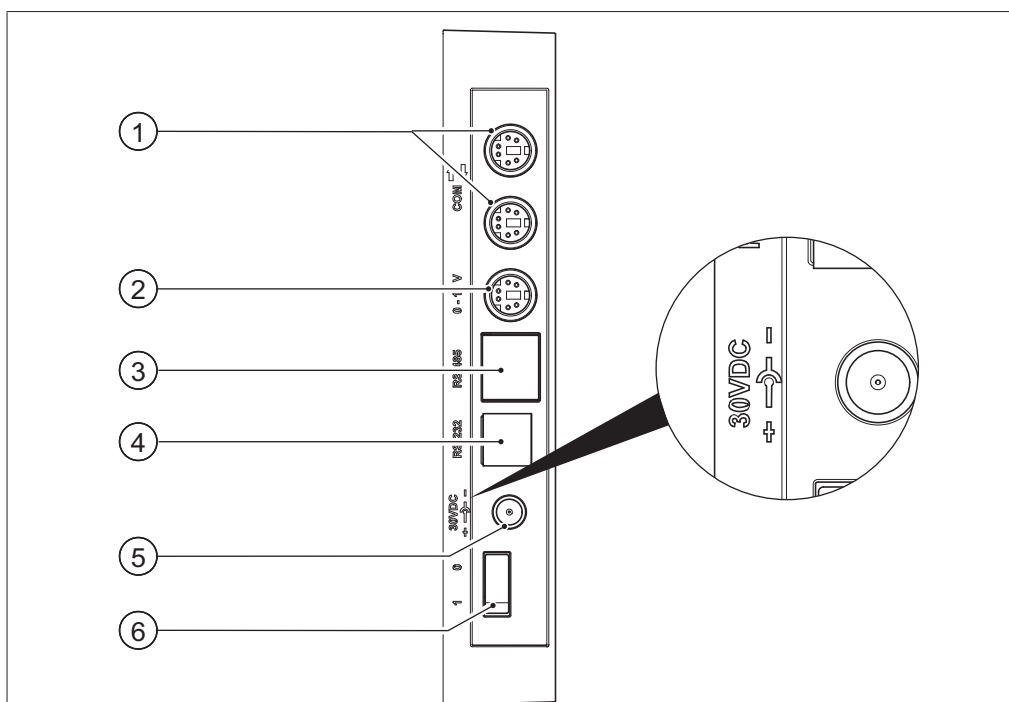

Fig. 4: Connections on the LegacyBox

- | | |
|---|---|
| 1 Standard BUCHI communication port (COM) | 4 RS-232 (not used) |
| 2 0 – 10 V communication port – for connecting pumps of other makes | 5 External power supply – for genuine BUCHI mains adaptor, 30 V, 30 W (see Accessories) |
| 3 RS-485 communication port – for connecting legacy BUCHI laboratory equipment (Vacuum Pumps V-700 / V-710, Rotavapors: R-210 / R-215, Recirculating Chiller F-1xx) | 6 On/Off switch |



NOTE

The external power supply is only necessary if the LegacyBox is not connected to a Rotavapor or a vacuum pump and is used for other vacuum control applications instead. Otherwise the vacuum pump or the Rotavapor supplies the LegacyBox with power.

0 – 10 V communication port

This connection comprises a 0 – 10 V output for connecting pumps of other makes and electrically isolated relay contacts. There is also a valve control contact.

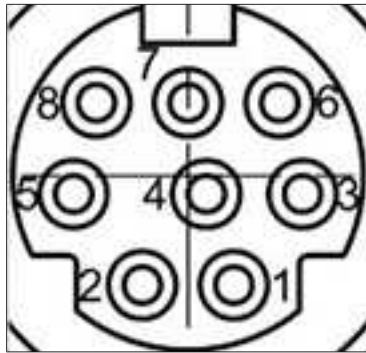
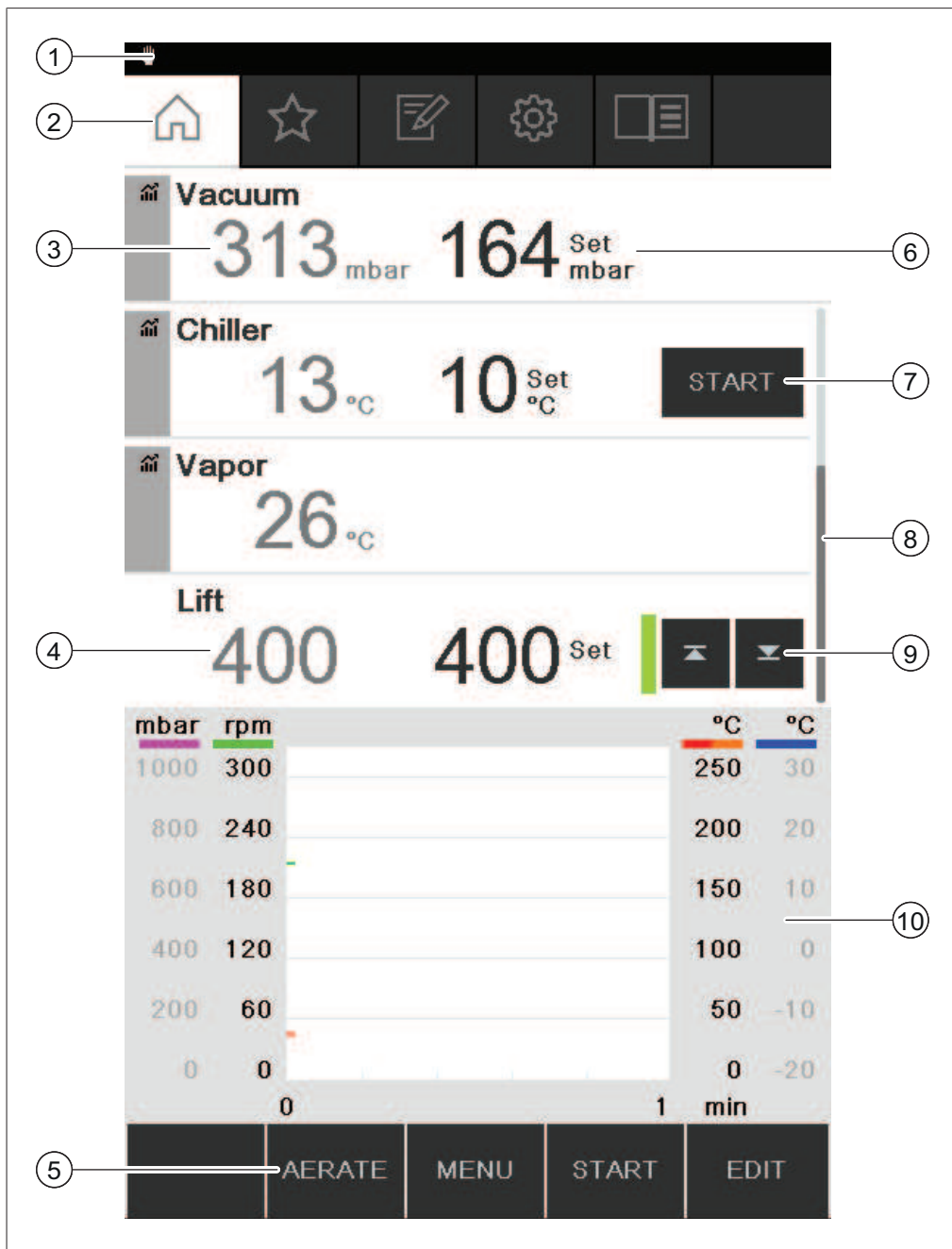

Fig. 5: 8-pin MiniDin pin assignment, view of socket

Pin 8-pin notation	Symbol	Description
1	Ground	Ground connection for valve and 10 V output
2	Valve	Vacuum valve connection
3		Spare
4	10 V output	0 – 10 V (max. 20 mA, min. 500 Ohm)
5	Relay In	Max. 30 V 2 A, electrically isolated
6		Spare
7		Spare
8	Relay Out	Max. 30 V 2 A, electrically isolated
S	Shield	Shield, connected to ground

3.4.5 Display



- | | |
|--|---------------------------------|
| 1 Status bar | 6 Current setting (e.g. vacuum) |
| 2 Menu bar | 7 Direct intervention buttons |
| 3 Current reading (e.g. vacuum) | 8 Scroll bar |
| 4 Lift position | 9 Lift control |
| 5 Function buttons (context-dependent) | 10 Graph display area |

**NOTE**

While distillation is in progress, the display is shown in inverse type. A progress bar for each process parameter shows the status on reaching the specified setting concerned.

3.4.6 Type plate

The type plate is on the rear of the Interface I-300 Pro.

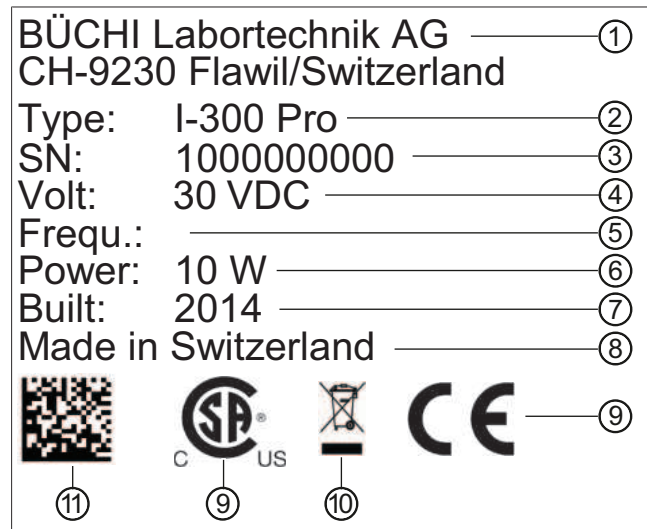

Fig. 6: Type plate (example)

- | | |
|----------------------------|--|
| 1 Company name and address | 7 Year of manufacture |
| 2 Device name | 8 Country of manufacture |
| 3 Serial number | 9 Approvals |
| 4 Input voltage | 10 Symbol for "Do not dispose of as household waste" |
| 5 Frequency | 11 Product code |
| 6 Maximum power rating | |







NOTE

The VacuBox and the LegacyBox each have their own type plate on the rear.

3.5 Navigating through the menu system

3.5.1 Main menu

Highest menu level

Symbol	Meaning	Sub-items
	Home page	<ul style="list-style-type: none"> • Process control parameters • Graphs
	Favorites	<ul style="list-style-type: none"> • Bookmarks for frequently used individual starting points
	Operating modes	<ul style="list-style-type: none"> • Manual • Timer • Continuous pumping • AutoDest • Drying (only with Rotavapor R-300) • Methods
	Configuration	<ul style="list-style-type: none"> • Servicing • Settings • Service • System information
	Libraries	<ul style="list-style-type: none"> • Solvent library • Your own solvent library • Wearing parts

3.5.2 Operating modes

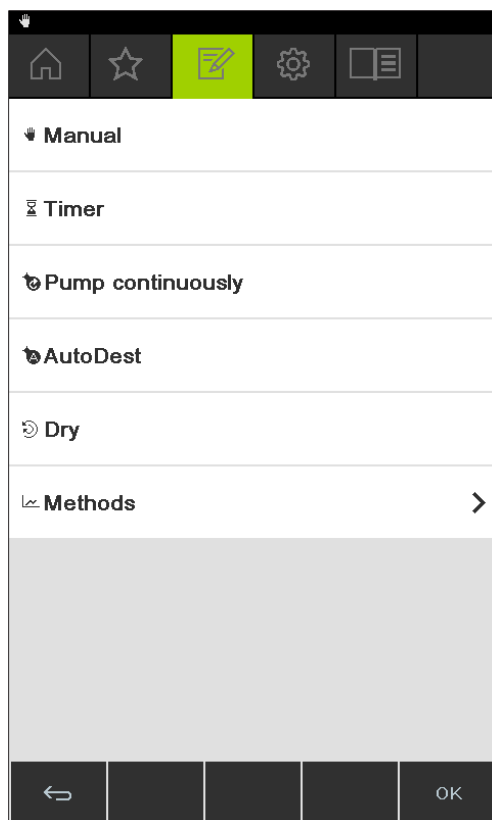

Fig. 7: "Operating modes" selected on main menu of Interface I-300 Pro

The Interface I-300 Pro distinguishes between the following operating modes for a distillation system:

Operating mode	Purpose	Consists of
Manual	Carrying out distillation with manually set parameters	User-definable configuration of specified settings for the individual process parameters: <ul style="list-style-type: none"> • Vacuum • Evaporating flask rotation • Heating bath temperature • Coolant temperature The actual values for the above parameters are displayed, plus: <ul style="list-style-type: none"> • Vapor temperature
Timer	Carrying out a distillation process with manually set parameters which is to be stopped after a set time has elapsed	User-definable configuration of specified settings for the timer and individual process parameters: <ul style="list-style-type: none"> • See "Manual" • Timer
Continuous pumping	Drying the system after distillation	Pump runs constantly and pressure can be set via pump speed in percent. <ul style="list-style-type: none"> • Pump speed

Operating mode	Purpose	Consists of
AutoDest	Carrying out automatic single or multi-stage distillation with specified settings for the vacuum continuously adjusted by the system	Precondition: AutoDest sensor connected to the system and supplying readings: <ul style="list-style-type: none"> • Coolant inlet temperature • Coolant outlet temperature • Vapor temperature The algorithm continuously adjusts the specified settings for the pressure. Process stops automatically as soon as distillation is completed.
Drying	Post-drying of contents of evaporating flask. (This feature is only available in conjunction with the Rotavapor R-300.)	Drying of evaporating flask contents. Evaporating flask rotates in alternating directions for a defined period of time. User-definable configuration of specified settings for the individual process parameters: <ul style="list-style-type: none"> • See "Manual" • Timer • Rotation interval
Methods	Carrying out distillation according to a sequence of programmed steps with defined times and parameters.	User programming of a method consisting of up to 12 steps. A step can be programmed as one of the following functions: <ul style="list-style-type: none"> • Gradient • Pause • Drying (only with Rotavapor R-300)

3.5.3 Configuration

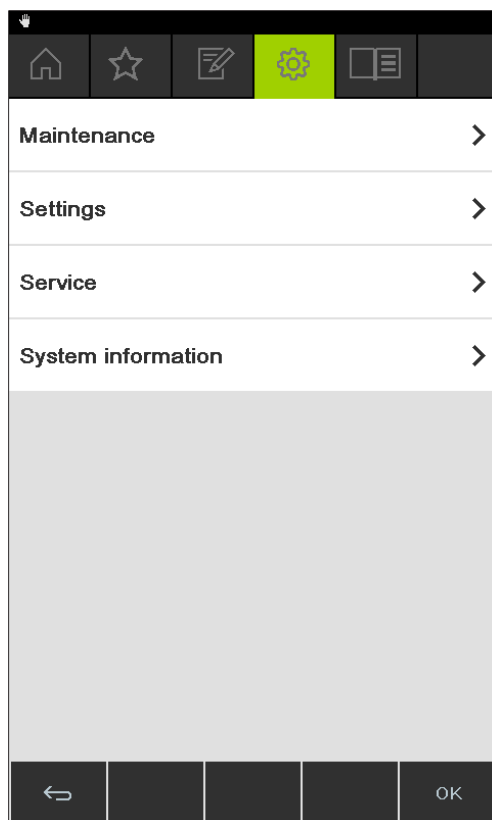

Fig. 8: "Configuration" selected on main menu of Interface I-300 Pro

The menu item "Configuration" on the main menu of the Interface I-300 Pro offers the following options:

Servicing

"Servicing" provides access to information on seal servicing and the option of carrying out a leak test on the distillation system.

Action	Option	Explanation
Leak test	START	For carrying out a leak test on the distillation system.
Seal servicing	Information	Hours of rotation since last service. Facility for resetting rotation hours counter.

Settings

The "Settings" submenu provides the facility for changing basic settings on the distillation system.

Action	Option	Explanation
Mobile connection QR code	Display	Interface unit shows QR code for the connected distillation system.
Mobile connection password	Display	For viewing password and entering on mobile device (alternative to QR code)
On finish: vent system	On/Off	System is vented after automatic or manual termination of distillation.

Action	Option	Explanation
On start: start rotation	On/Off	Evaporating flask starts rotating when distillation is started.
On finish: stop rotation	On/Off	Evaporating flask stops rotating after automatic or manual termination of distillation.
On start: immerse flask	On/Off	Evaporating flask is automatically immersed in the heating bath when distillation is started.
On finish: lift out flask	On/Off	Evaporating flask is automatically lifted out of the heating bath after automatic or manual termination of distillation.
On finish: stop heating	On/Off	Heating of heating bath stops after automatic or manual termination of distillation.
On finish: stop cooling	On/Off	The Recirculating Chiller F-3xx automatically switches off after automatic or manual termination of distillation.
On finish: play sound	On/Off	An audible signal is sounded after automatic or manual termination of distillation.
Pressure hysteresis	Entry of pressure	Entry of figure for the maximum allowable difference between the actual vacuum and the specified figure before the vacuum pump switches on again.
Record data	On/Off	The following process data is recorded on an SD card: specified setting and actual readings for pressure, rotation, heating bath, recirculating chiller. Actual reading for vapor temperature. Events such as AERATE and defoaming. Difference between inlet and outlet temperature at AutoDest sensor.
Language	Choice of language used for Interface display	English, Deutsch, Francais, Italiano, Espanol, Russian, Portugues, Japanese, Chinese, Indonesian, Korean
Button tone	On/Off	A beep sounds when a function button or the navigation control is pressed.
Seal servicing information	On/Off	The interface shows information about regular servicing of the system seals. The message appears periodically after every 500 hours of rotation.
Temperature unit	Choice of unit for indication of temperatures	°C (Celsius), °F (Fahrenheit) or K (Kelvin)
Pressure unit	Choice of unit for indication of (negative) pressure	hPa (hectopascals), mbar (millibars), torr (= mmHg), mmHg (millimeters of mercury)

Action	Option	Explanation
Height above sea level	Entry of figure	Altitude of location above mean sea level: max. 4000 m. For determination of max. allowable pressure when working with the solvent library.
Max. permissible pressure	Entry of figure	Max. pressure level present in the system: max. 1400 mbar.
Max. pump delivery	Entry of figure	Max. pump speed in %: 10 – 100 %.
Display brightness	Entry of figure	Display illumination level in %: 0 – 100 %.
Current date	Entry of figure	Manual entry of date. Necessary for identification of recorded data.
Current time	Entry of figure	Manual entry of time. Necessary for identification of recorded data.
eco mode	On/Off and entry of figures	Settings for eco mode in respect of "Activation delay" (minutes), "Heating bath temperature reduction" and "Coolant temperature increase"
Reduced display	On/Off and reduced display in the "Action" column (only if Rotavapor R-220 Pro connected)	Reduced number of parameters on the home screen to avoid duplication with local display on the Rotavapor R-220 Pro.
Network	Entry of details	System name DHCP: Yes/No Network addresses for "Device IP address", "Gateway", "Subnet mask", "Server IP address" BUCHI Cloud: Yes/No
Delete APP connection	Confirmation question	All connections settings entered for the device are reset.

Service

The "Service" submenu provides options for adjusting/calibrating the connected measuring instruments.

Action	Option	Consists of
Calibrate AutoDest sensor	Perform calibration	Calibration sequence between the two condenser sensors. Precondition: the two condenser sensors are at the same temperature. See Chapter 8.5 "Calibrating AutoDest sensor", page 115.
Pressure offset	Entry of reference figure for measuring system pressure	The pressure inside the distillation system is measured by a reference sensor. That reading is entered as the reference figure for the system's internal pressure sensor. See Chapter 8.6.1 "Offset calibration", page 118.

Action	Option	Consists of
Pressure calibration	Calibration of pressure sensor and entry of reference pressure	The pressure sensor is calibrated in five stages for the following set pressures: - approx. 950 mbar (ambient pressure) - 800 mbar - 600 mbar - 400 mbar - 200 mbar - 10 mbar See Chapter 8.6.2 "Simple calibration", page 119.
Loading factory calibration	Calibration reset	The current pressure sensor calibration data is overwritten by the factory calibration settings. See Chapter 8.6.3 "Loading factory calibration", page 120.

System information

The submenu "System information" provides details of the laboratory equipment connected and on network connection diagnosis.

3.5.4 Solvent library/Own solvent library

The Interface I-300 Pro has an internal solvent library. The preconfigured solvent library lists the most common solvents (e.g. ethanol) in alphabetical order. For each solvent, the library contains an algorithm that calculates the optimum vacuum setting from the actual figures for heating bath temperature and coolant temperature. The specified vacuum setting is a dynamic figure that alters automatically according to the current temperatures of coolant and heating bath until they too have reached their specified settings. You can also create your own solvent library in which you can enter details of more solvents.



NOTE

The individual solvents can be saved as favorites. A distillation process can be started directly from the solvent library.

Wear parts

The Interface I-300 Pro offers a list of wearing parts for the BUCHI Rotavapor system. The list is divided into two columns. The left-hand column itemizes the wearing parts in alphabetical order. The right-hand column shows the order numbers for the wearing parts.

3.6 Specifications supplied

The specifications detailed below apply in combination with a Rotavapor R-300.

3.6.1 Interface I-300 Pro

Component	Quantity supplied
Interface I-300 Pro	1
SD card, 1 GB	1
Device bracket assembly:	
• Screw, M6x16	1
• Torx key, Tx20	1
• Torx key, Tx30	1
• Holder	1
• Backplate	1
• Knurled-head screw	1

3.6.2 VacuBox

Component	Quantity supplied
VacuBox	1
VacuBox accessory set:	
• Screw, M4x20	2
• Torx key, Tx20	1
• MiniDIN lead, 0.3 m	1



NOTE

The VacuBox is an essential requirement for use of the Interface I-300/I-300 Pro.

3.6.3 LegacyBox

Component	Quantity supplied
LegacyBox	1
LegacyBox accessory set:	
• Screw, M4x30	2
• Screw, M4x50	2
• Torx key, Tx20	1
• MiniDIN lead, 0.3 m	1

3.7 Technical data

3.7.1 Interface I-300 Pro

Dimensions (W x H x D)	122 x 221 x 50 mm
Weight	600 g
Power supply voltage	30 VDC \pm 5 %
Power consumption	10 W
Enclosure rating	IP21
Approval	CE/CSA

3.7.2 VacuBox

Dimensions (W x H x D)	50 x 167 x 57 mm
Weight	400 g
Power supply voltage	30 VDC \pm 5 %
Power consumption	8 W
Solenoid valve power supply	24 V
Measurement range	1400 – 0 mbar
Regulating range	Ambient pressure – 0 mbar
Measurement accuracy	\pm 2 mbar (after calibration at constant temperature)
Temperature compensation	0.07 mbar/K
Hysteresis	Automatic or 1 – 200 mbar
Vacuum connection	GL14
Enclosure rating	IP21
Approval	CE/CSA

3.7.3 LegacyBox

Dimensions (W x H x D)	50 x 167 x 28 mm
Weight	200 g
Power supply voltage	30 VDC \pm 5 %
Power consumption	8 W
Enclosure rating	IP21
Approval	CE/CSA

3.7.4 Ambient conditions

Max. altitude above sea level	2000 m
Ambient temperature	5 - 40 °C
Maximum relative humidity	80 % for temperatures up to 31 °C decreasing linearly to 50 % at 40 °C

The laboratory equipment described in this document may only be used in indoor areas.

3.7.5 Materials

Component	Material
Pressure foil	Polyester
Casing	PBT
Vent tube connection	PPS
Pressure sensor	Al ₂ O ₃ 96%

4 Transport and storage

4.1 Transport

IMPORTANT

Risk of breakage due to incorrect transportation

- ▶ Make sure that all parts of the device are safely packed in such a way as to prevent breakage, ideally in the original box.
- ▶ Avoid sharp movements during transit.

-
- ▶ After transportation, check the device for damage.
 - ▶ Damage that has occurred in transit should be reported to the carrier.
 - ▶ Keep packing for future transportation.

4.2 Storage

- ▶ Make sure that the ambient conditions are complied with (see Chapter 3.7 "Technical data", page 29).
- ▶ Wherever possible, store the device in its original packaging.
- ▶ After storage, check the device for damage and replace if necessary.

5 Installation

5.1 Fitting the Interface I-300/I-300 Pro

The Interface I-300/I-300 Pro can be mounted on one of the following BUCHI laboratory devices:

- Rotavapor R-300
- Vacuum Pump V-300
- Rotavapor R-220 Pro

Alternatively, the Interface I-300/I-300 Pro can be mounted separately on a laboratory stand, see Chapter 5.1.4 "Mounting interface unit on laboratory stand (optional accessory)", page 36.

5.1.1 Mounting interface on Rotavapor R-300

The Interface I-300 Pro can be mounted and connected up on the vertically adjustable arm of the Rotavapor R-300.

Tools required: Torx keys Tx20 and Tx30

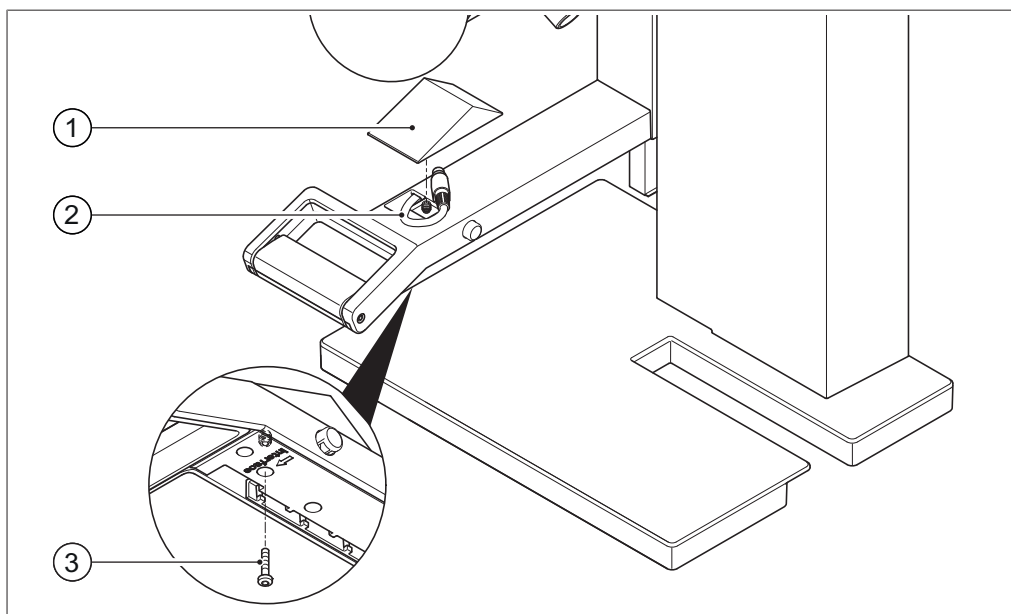

Fig. 9: Handle of Rotavapor R-300

1 Cover

2 Communication cables

3 Fixing screw for cover

- ▶ Remove the screw on the underside of the vertically adjustable arm (3) using a Torx key and remove the cover (1) from the top of the arm.
- ▶ Remove the pre-fitted communication cable (2) from the cover.

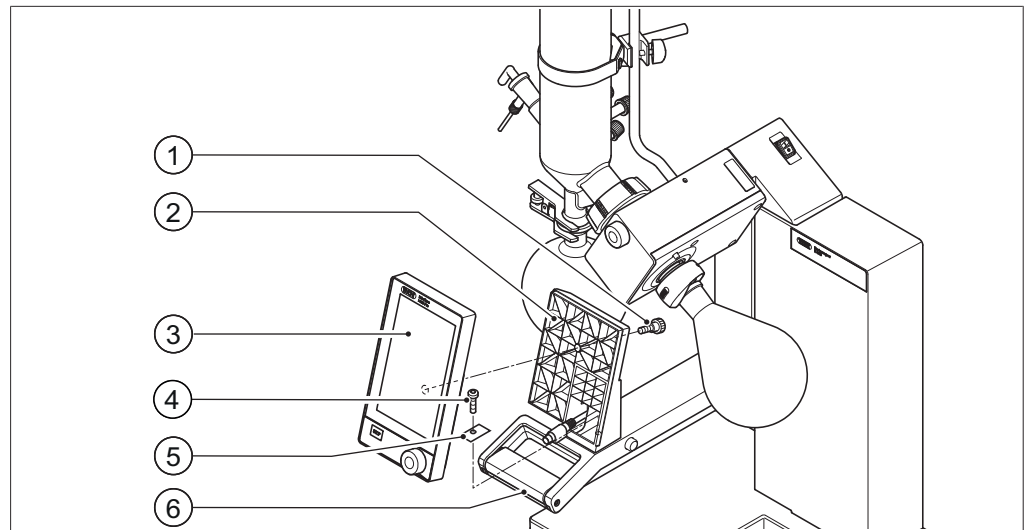

Fig. 10: Fitting the holder and interface unit on the handle

- | | |
|-----------------------------|----------------------------|
| 1 Knurled-head screw | 4 Fixing screw for holder |
| 2 Holder for interface unit | 5 Metal plate |
| 3 Interface unit | 6 Rotavapor arm and handle |
- ▶ Position the holder (2) for the interface unit on the Rotavapor arm (6). At the same time, feed the communication cable through the bottom hole in the holder.
 - ▶ Fix the holder to the Rotavapor arm with a screw (4). When doing so, pass the screw through the hole in the metal plate (5).
 - ▶ Connect the communication cable to the COM port on the rear of the interface unit.
 - ▶ Position the interface unit (3) on the holder and fix it in place using the knurled-head screw (1) supplied. When doing so, make sure that the communication cable is not trapped.

5.1.2 Fitting interface unit on Vacuum Pump V-300

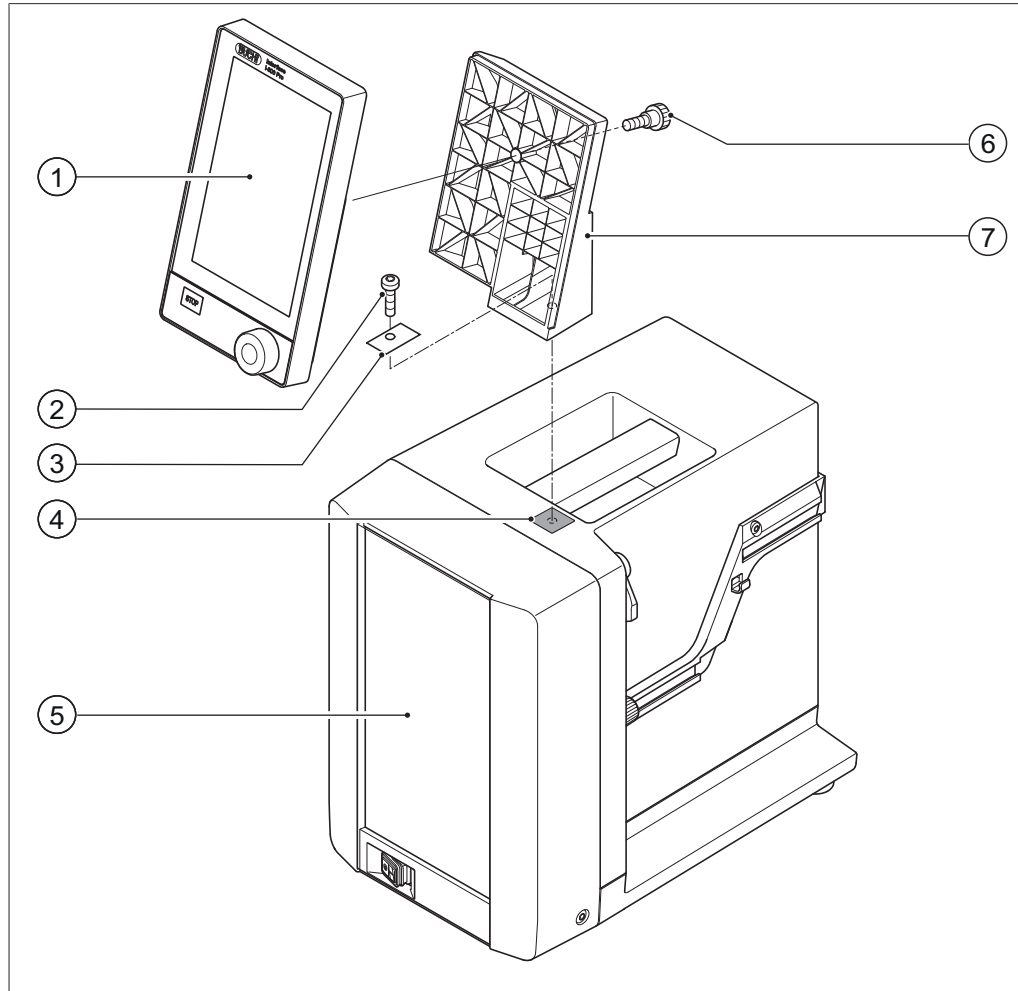

Fig. 11: Fitting interface unit on Vacuum Pump V-300

- | | |
|---------------------------------|----------------------|
| 1 Interface unit | 5 Casing front |
| 2 Fixing screw for holder | 6 Knurled-head screw |
| 3 Metal plate | 7 Holder |
| 4 Rubber plug and threaded hole | |

Tools required:

- Torx key Tx30

The Interface I-300 Pro can be mounted on the top of the Vacuum Pump V-300 using a holder.

- ▶ Remove the rubber plug (4) from the top panel of the vacuum pump. Use a screwdriver if necessary. Underneath the rubber plug is a threaded hole for a screw.
- ▶ Position the holder (7) over the threaded hole (4) and fix it in place using the screw (2) supplied. When doing so, pass the screw through the hole in the metal plate (3).
- ▶ Feed the communication cable through the holder from the rear and connect it to the COM port on the back of the interface unit.
- ▶ Position the interface unit (1) on the holder and fix it in place using a knurled-head screw (6) inserted from the back.

5.1.3 Mounting interface unit on Rotavapor R-220 Pro

The Interface I-300 Pro is fitted directly adjacent to the display of the Rotavapor R-220 Pro.

- ▶ Remove the cover to the left of the Rotavapor display. (Behind the cover you will see a communication cable with a standard BUCHI communication connection and a LAN cable.)

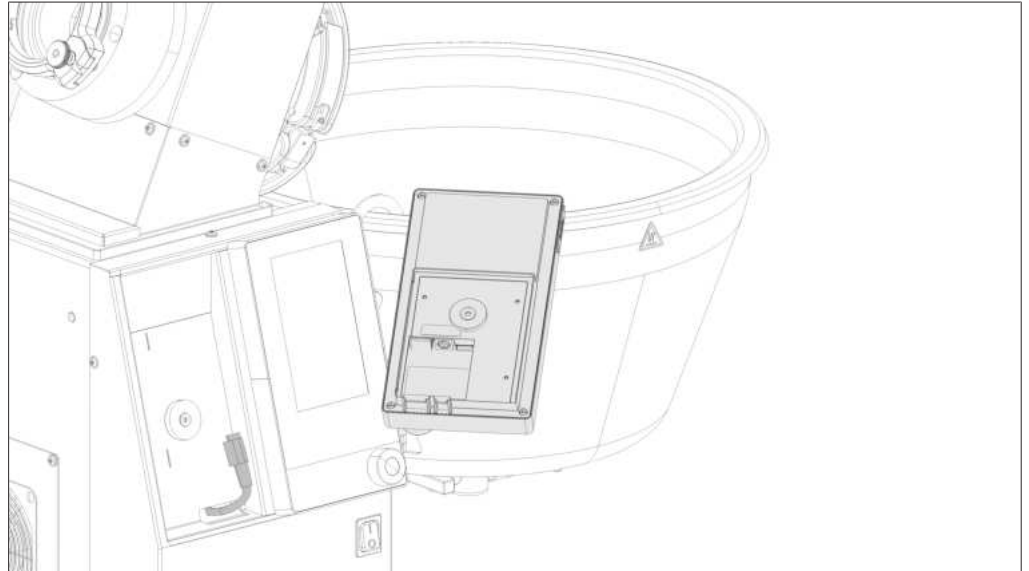

- ▶ Position metal plate on back of Interface I-300 Pro and screw in place.
- ▶ Connect Rotavapor communication cable to the interface unit.
- ▶ Connect Rotavapor LAN cable to the interface unit. (For a network connection, there must be a connection from the rear panel of the Rotavapor to a network.)

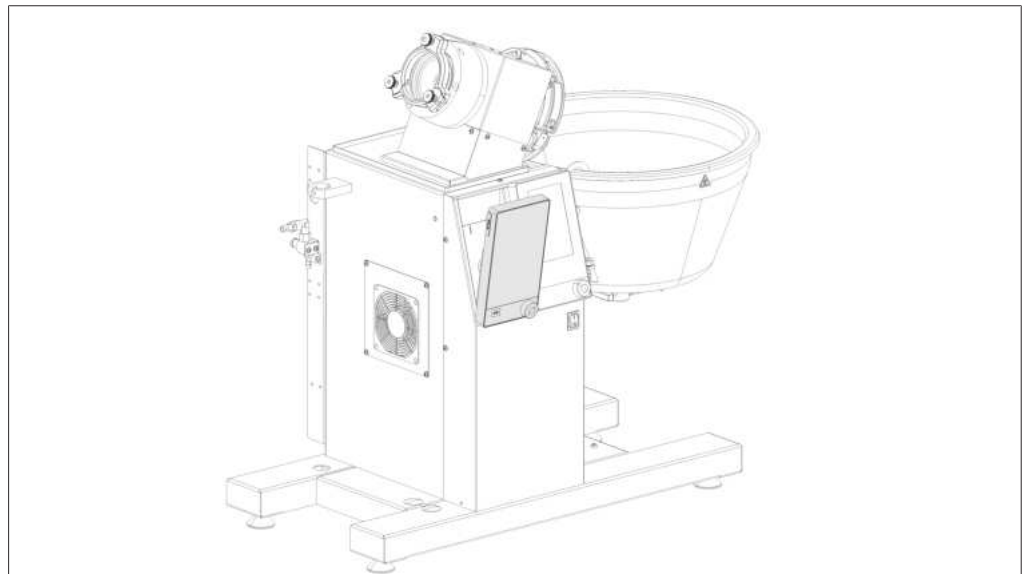

- ▶ Insert the interface unit into the recess next to the Rotavapor display. The interface unit is held in place by means of the attached metal plate and a magnet in the Rotavapor casing.

5.1.4 Mounting interface unit on laboratory stand (optional accessory)

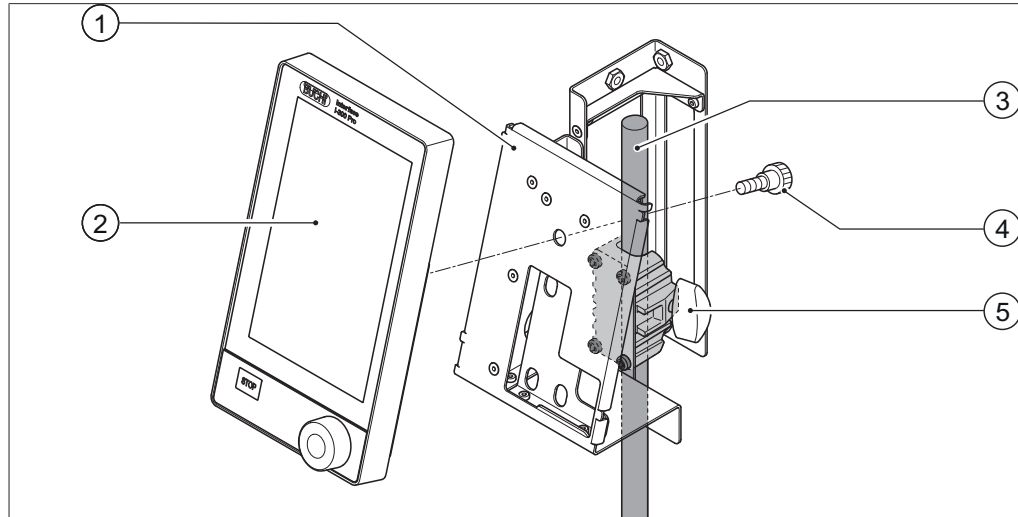

Fig. 12: Mounting interface unit on laboratory stand

- | | |
|-----------------------------|----------------------|
| 1 Holder for interface unit | 4 Knurled-head screw |
| 2 Interface unit | 5 T-screw |
| 3 Laboratory stand | |

The Interface I-300 Pro can also be mounted on a laboratory stand using a holder.

- ▶ Position the holder (1) on the laboratory stand (3) and fix it in place using the T-screw (5).
- ▶ Position the interface unit (2) on the flat face (1) of the holder and fix it in place using a knurled-head screw (4).

5.1.5 Mounting interface unit on a wall bracket (optional accessory)

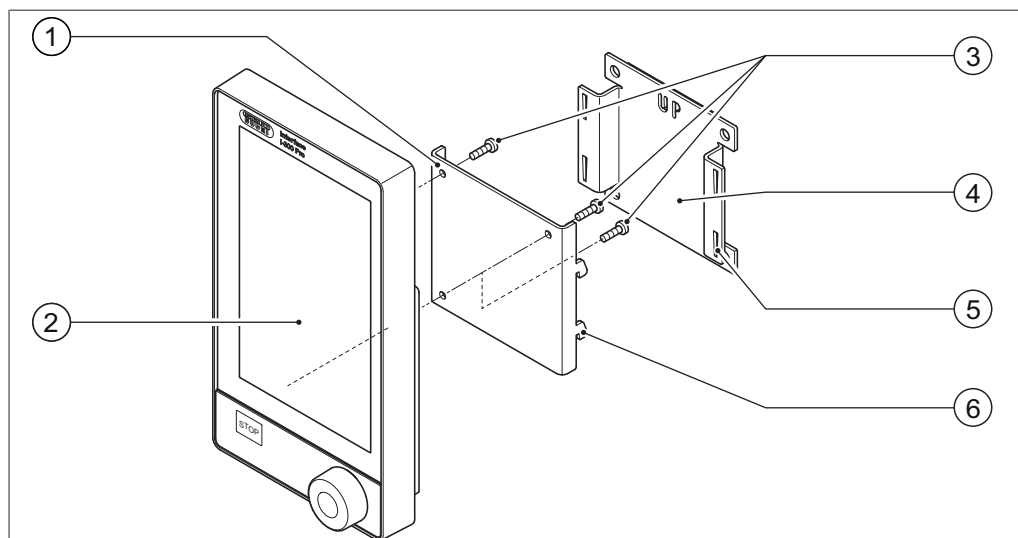

Fig. 13: Two-piece wall bracket for interface unit

- | | |
|------------------------------------|------------------------------|
| 1 Front plate of wall bracket | 4 Rear plate of wall bracket |
| 2 Interface unit | 5 Slot in rear plate |
| 3 Fixing screws for interface unit | 6 Lug on front plate |

The Interface I-300 Pro can also be mounted directly onto a plastered or tiled wall or a laboratory fume hood with the aid of a wall bracket.

- ▶ Position the rear plate (4) of the two-part wall bracket on the wall. Note: the word "UP" stamped in the rear plate must be at the top.
- ▶ Option 1: peel protective foil off the back of the plate and press the plate firmly against the wall/glass panel in the desired position so it is held in place by the self-adhesive pad.
- ▶ Option 2: mark the positions of the four holes in the rear plate, drill four holes in the wall in those positions and fix the plate to the wall using screws.
- ▶ Position the interface unit (2) on the outer face of the front plate (1) and fix it in place using three screws (3).
- ▶ Fit the front plate together with interface unit onto the rear plate. As you do so, locate the lugs (6) on the front plate in the slots (5) on the rear plate and then press the front plate down.

5.2 Connecting the Interface I-300/I-300 Pro

The Interface I-300/I-300 Pro can be connected either to an individual BUCHI laboratory device or to a complete distillation system.

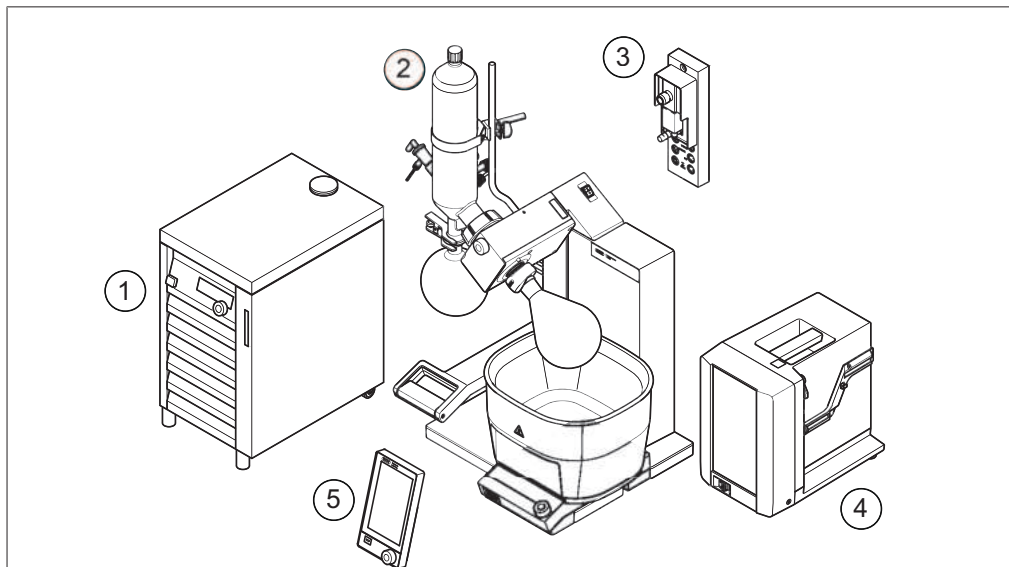

Fig. 14: Interface unit, VacuBox, Rotavapor, vacuum pump and recirculating chiller

- | | |
|-------------------------------------|-----------------------------|
| 1 Recirculating Chiller F-3xx | 4 Vacuum Pump V-300 |
| 2 Rotavapor R-300 with Heating Bath | 5 Interface I-300/I-300 Pro |
| 3 VacuBox | |

A complete BUCHI distillation system typically consists of the following components:

- Rotavapor R-300 with heating bath
- Vacuum Pump V-300
- Recirculating Chiller F-3xx
- VacuBox
- Interface I-300/I-300 Pro

Data communication between the BUCHI laboratory equipment takes place via the standard BUCHI communication ports. See Chapter 5.2.2 "Overview: setting up communication connections", page 39.

The refrigerant circulates around the distillation system through a separate tubing system. See Chapter 5.2.3 "Overview: setting up coolant tubing connections", page 40.

The laboratory equipment to be evacuated is connected to the vacuum pump and the VacuBox by means of vacuum tubing. See Chapter 5.2.4 "Overview: setting up vacuum tubing connections", page 41.

5.2.1 Connecting communication cables to interface unit

The communication connections between the Interface I-300 Pro, the VacuBox and the other BUCHI laboratory equipment are established using the standard BUCHI communication cable (green cable). The corresponding connection sockets are on

the rear panels of the devices and are marked "COM" for identification. Details of the precise positions of the connection sockets are provided in the operating instructions for the devices.

- For connection options on the Interface I-300 Pro see Chapter 3.4.2 "Rear view", page 14.
- For connection options on the VacuBox see Chapter 3.4.3 "VacuBox (connections)", page 15.

5.2.2 Overview: setting up communication connections

The laboratory apparatus can be connected in any order. **Important:** as well as the Interface I-300/I-300 Pro, a VacuBox also has to be connected.

Below is an example of the connections between the laboratory apparatus.

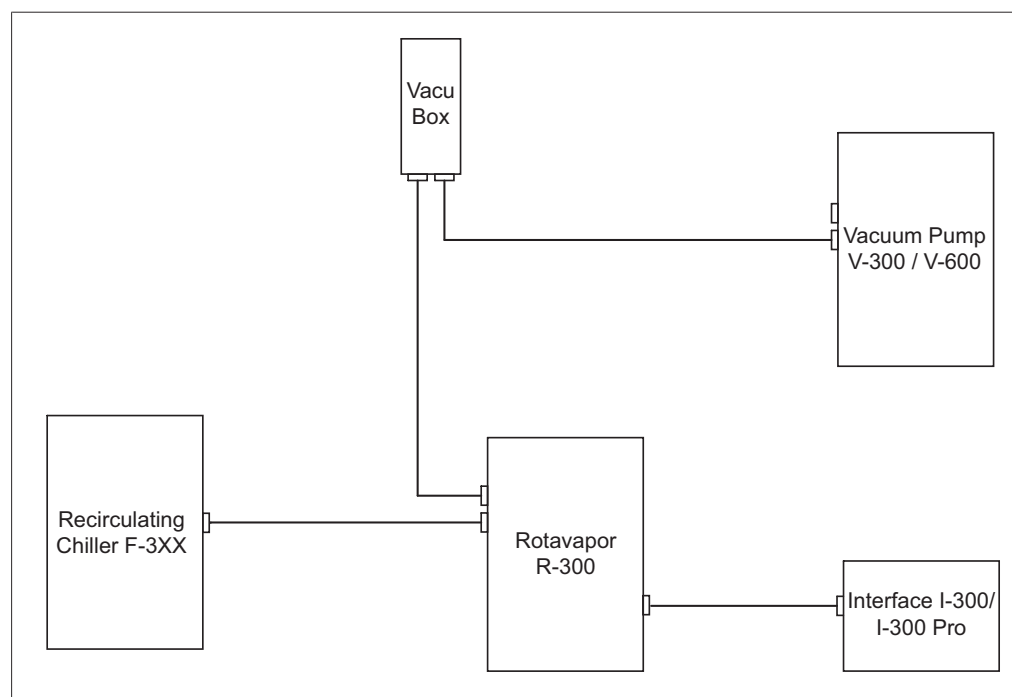

Fig. 15: Schematic diagram of communication connections between the BUCHI laboratory equipment (example)

- ▶ Connect the Recirculating Chiller F-3xx to the Rotavapor R-300.
- ▶ Connect the Rotavapor R-300 to the VacuBox.
- ▶ Connect the VacuBox to the Vacuum Pump V-300/V-600.
- ▶ Connect Rotavapor to the Interface I-300/I-300 Pro.



NOTE

Connections on R-220 Pro:

Information on the connection of communication cables, coolant and vacuum tubing with the Rotavapor R-220 Pro can be found in the operating instructions for the Rotavapor R-220 Pro.

5.2.3 Overview: setting up coolant tubing connections

The tubing connections between the various items of BUCHI laboratory equipment form a sealed circulation system. The starting and finishing point is always the recirculating chiller (F-3xx).

Below is an example of the tubing connections between the laboratory apparatus.

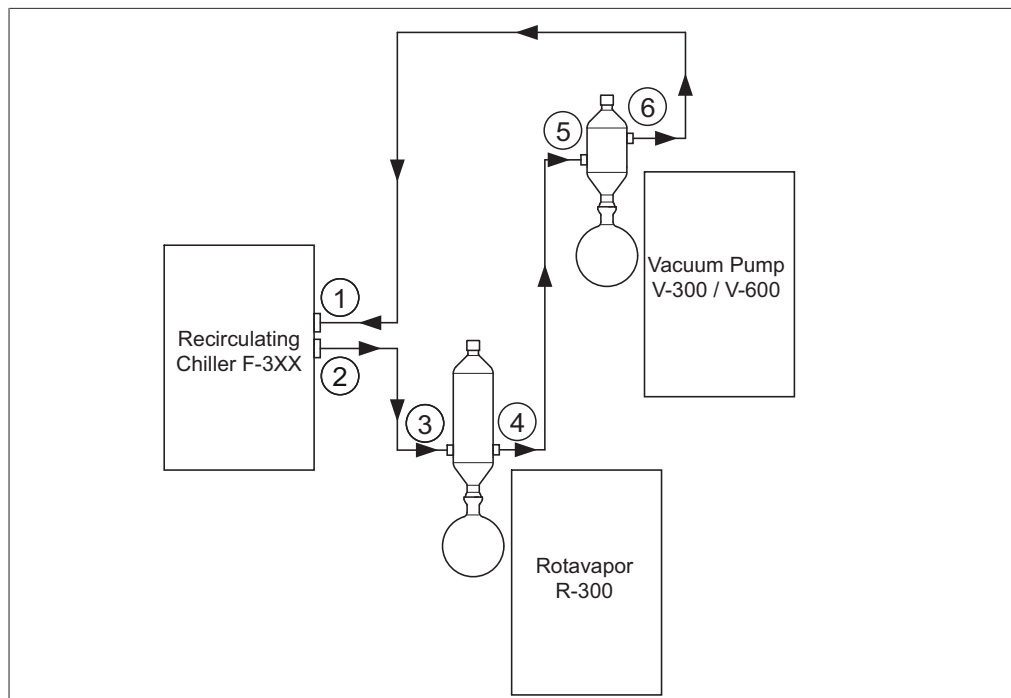

Fig. 16: Coolant tubing connections in a BUCHI distillation system (example)

- | | |
|---|---|
| 1 Inlet on Recirculating Chiller F-3xx | 4 Condenser outlet on Rotavapor R-300 |
| 2 Outlet on Recirculating Chiller F-3xx | 5 Secondary condenser inlet on Vacuum Pump V-300 |
| 3 Condenser inlet on Rotavapor R-300 | 6 Secondary condenser outlet on Vacuum Pump V-300 |

- ▶ Connect a tube between the outlet of the recirculating chiller (2) and the inlet of the condenser on the Rotavapor R-300 (3).
- ▶ Connect a tube between the outlet of the condenser on the Rotavapor R-300 (4) and the inlet of the secondary condenser on the Vacuum Pump V-300 (5).
- ▶ Connect a tube between the outlet of the secondary condenser on the Vacuum Pump V-300 (6) and the inlet of the recirculating chiller (1).



NOTE

Connections on R-220 Pro:

Information on the connection of communication cables, coolant and vacuum tubing with the Rotavapor R-220 Pro can be found in the operating instructions for the Rotavapor R-220 Pro.

5.2.4 Overview: setting up vacuum tubing connections

The vacuum tubing connections in a typical BUCHI distillation system lead from the Rotavapor R-300 via a Wouff bottle to the Vacuum Pump V-300/V-600. The vacuum is measured by means of the VacuBox, which is also connected to the Wouff bottle.

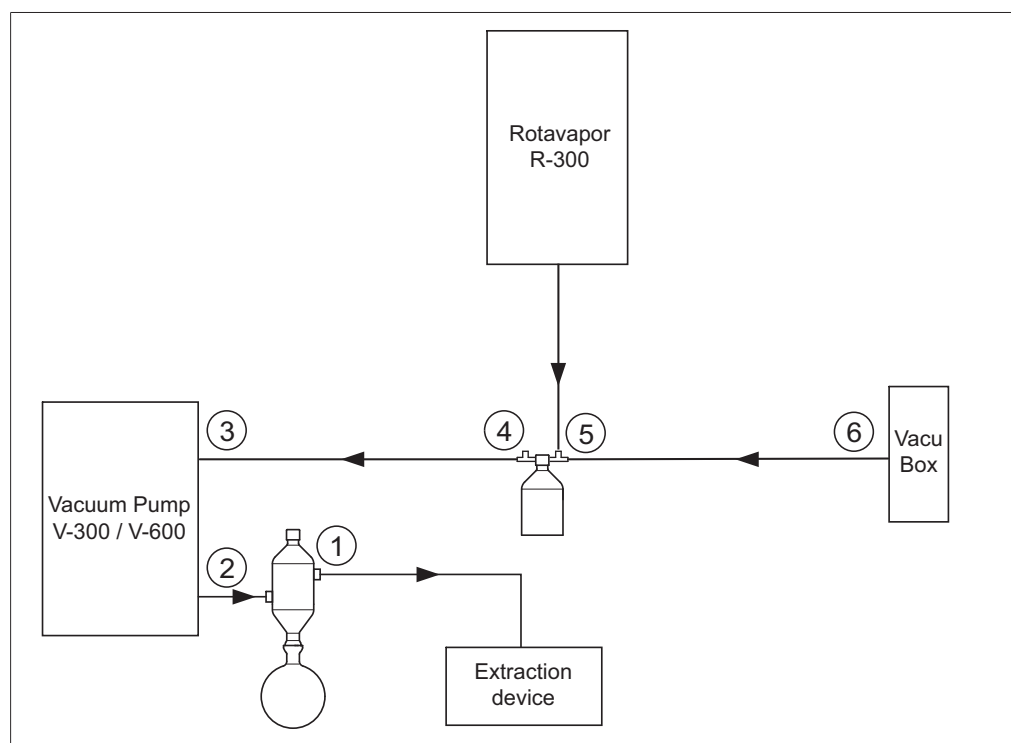

Fig. 17: Coolant tubing connections in a BUCHI distillation system

- | | |
|----------------------------------|------------------------------|
| 1 Secondary condenser outlet | 4 Wouff bottle outlet (PUMP) |
| 2 Vacuum Pump V-300/V-600 outlet | 5 Wouff bottle inlet (CONTR) |
| 3 Vacuum Pump V-300/V-600 inlet | 6 VacuBox vacuum connection |

- ▶ Connect a tube between the Rotavapor R-300 and the top inlet of the Wouff bottle.
- ▶ Connect a tube between the outlet of the Wouff bottle marked PUMP (4) and the pump inlet (3).
- ▶ Connect the secondary condenser to the pump outlet (2).
- ▶ For measuring and controlling the vacuum, connect a tube between the inlet of the Wouff bottle marked CONTR (5) and the VacuBox (6).

The pressure is measured in the VacuBox. The current working pressure can be indicated and controlled by means of the Interface I-300/I-300 Pro.



NOTE

The VacuBox and Wouff bottle can be mounted either on the Rotavapor R-300 or the Vacuum Pump V-300/V-600. What is important is that the VacuBox and Wouff bottle are as close as possible to each other (on the same device) as otherwise there is a vacuum control lag.



NOTE

Connections on R-220 Pro:

Information on the connection of communication cables, coolant and vacuum tubing with the Rotavapor R-220 Pro can be found in the operating instructions for the Rotavapor R-220 Pro.

5.3 Connecting AutoDest sensor to vapor temperature sensor (optional accessory)

The Interface I-300 Pro offers a program for carrying out an automatic distillation process (see Performing automatic distillation). Automatic distillation requires connection of an AutoDest sensor to the Rotavapor R-300. The AutoDest sensor is connected to the inlet and outlet of the cooling condenser and continuously measures the following temperatures:

- Temperature of the incoming coolant
- Temperature of the outgoing coolant
- Temperature of the vapor exiting the evaporating flask

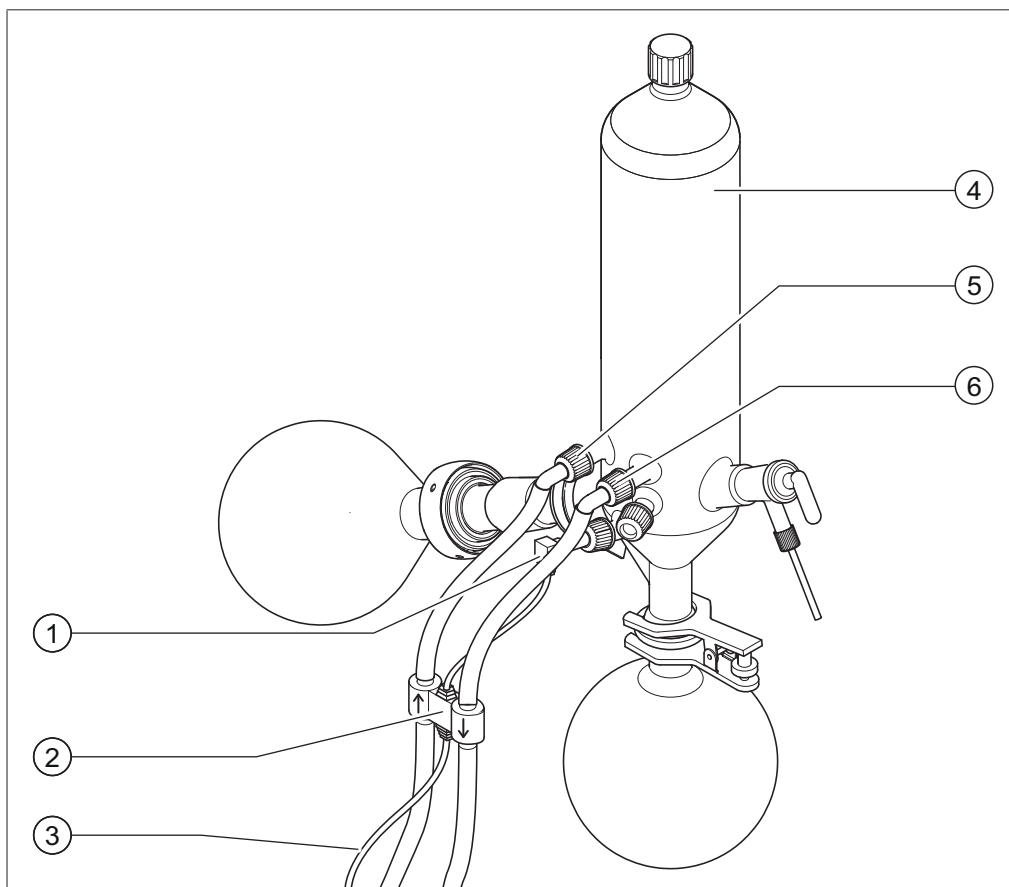

Fig. 18: AutoDest sensor, vapor temperature sensor and cooling condenser with evaporating flask and receiving flask of a Rotavapor R-300

- | | |
|--|-------------------------------|
| 1 Vapor temperature sensor | 4 Cooling condenser |
| 2 AutoDest sensor | 5 Coolant inlet on condenser |
| 3 Communication connection between AutoDest sensor and VacuBox | 6 Coolant outlet on condenser |



NOTE

There are two arrows stamped on the AutoDest sensor indicating the direction of flow for the coolant. The coolant tubing should be connected accordingly.

- ▶ Connect two tubes between the AutoDest sensor (2) and the cooling condenser (4). When doing so pay attention to the direction of flow of the coolant. The arrows on the AutoDest sensor indicate the direction of flow.

**NOTE**

The distance between the AutoDest sensor and the cooling condenser should not be more than 10 to 20 cm so as not to falsify the readings for the incoming and outgoing coolant temperatures in the distillation system.

- ▶ Connect a tube between the coolant inlet (5) on the AutoDest sensor and the outlet of the recirculating chiller.
- ▶ Connect a tube between the coolant outlet (6) on the AutoDest sensor and either the inlet of the recirculating chiller or another cooling condenser.
- ▶ Insert a vapor temperature sensor (1) in the cooling condenser and fix it in place.
- ▶ Connect the outgoing cable (3) from the AutoDest sensor to the VacuBox. Use the connection marked "VT/AS" for this lead.

**NOTE**

The coolant must not contain any air bubbles as otherwise proper functioning of the AutoDest sensor is not guaranteed.

**NOTE**

Installing automatic mode sensor on R-220 Pro:

The installation of the automatic mode sensor on the Rotavapor R-220 Pro is described in the operating instructions of the Rotavapor R-220 Pro.

5.4 Connecting foam sensor (optional accessory)

The foam sensor uses infra-red to measure the level of foam formation inside the evaporating flask and initiates one or more short venting bursts to combat the foam.

When de-foaming is active, it is indicated by the symbol  on the status bar of the Interface I-300/I-300 Pro.

The foam sensor passes through the cooling condenser of the R-300 into the evaporating flask. The communication cable from the foam sensor is connected to the VacuBox, see Chapter 3.4.3 "VacuBox (connections)", page 15.

IMPORTANT

Risk of heat damage to electronic components

- Only use the foam sensor at vapor temperatures up to 85 °C.

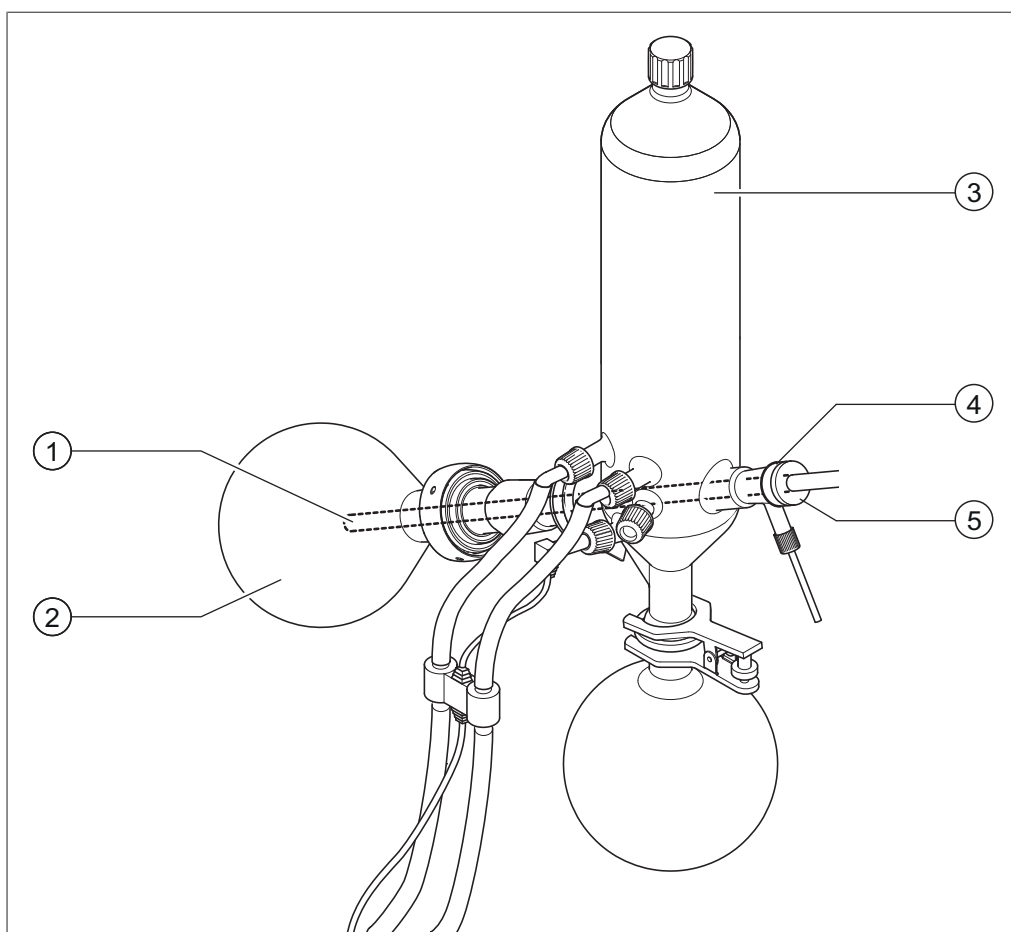

Fig. 19: Foam sensor in the evaporation unit of a Rotavapor R-300

- | | |
|---------------------|--------------------------|
| 1 Foam sensor | 3 Cooling condenser |
| 2 Evaporating flask | 4 Holder for foam sensor |
| | 5 Clamp nut |

- Fit the tapered holder (4) over the upper end of the foam sensor (1).
- Feed the foam sensor together with holder through the cooling condenser and the vapor duct into the evaporating flask of the Rotavapor R-300 and fix in place with the clamp nut. When inserting the foam sensor, make sure that the sensor rod

passes centrally through the components.

The tip of the foam sensor should be positioned approx. 4 to 5 cm below the ground neck of the evaporating flask.

- ▶ Connect the communication cable from the foam sensor to the VacuBox. Plug the connector into the socket marked "FS". For details, see Chapter 3.4.3 "VacuBox (connections)", page 15.

**NOTE**

Immersion angle > 30°:

If the immersion angle of the Rotavapor is to be more than 30°, the small washer supplied must be fitted on the foam sensor in order to prevent the condensate running back into the evaporating flask. The washer is slid over the glass tube of the foam sensor so that it comes to rest in the area below the condensate trap of the cooling condenser. The tip of the washer should point downwards.

**NOTE**

Installing foam sensor on the R-220 Pro:

The installation of the foam sensor on the Rotavapor R-220 Pro is described in the operating instructions of the Rotavapor R-220 Pro.

5.5 Connecting valve unit for external vacuum

The Interface I-300 Pro can be used together with the VacuBox to control an external vacuum. For precise control of the vacuum, the use of a Woulff bottle is also recommended.

The apparatus can be mounted on a laboratory stand, see Chapter 5.1.4 "Mounting interface unit on laboratory stand (optional accessory)", page 36.

- ▶ Connect the vacuum valve to the VacuBox using a communication cable plugged into the connection marked VALVE.
- ▶ Connect vacuum tubing between the laboratory apparatus to be evacuated, the VacuBox and the external vacuum unit.
- ▶ If a Rotavapor is not connected, connect the VacuBox to the mains adaptor using an adaptor cable and plug the mains adaptor into the external power supply.



NOTE

Changing the hysteresis:

To adjust the regulation accuracy, the hysteresis can be altered on the interface unit, see Chapter 3.5.3 "Configuration", page 23.



NOTE

Connecting VacuBox with R-220 Pro:

If the Interface I-300 Pro and the VacuBox are operated in the Rotavapor R-220 Pro system, the following points should be noted: The external valves must always be connected to the Rotavapor R-220 Pro even if there is an alternative connection on the VacuBox.

5.6 Operating I-300 and I-300 Pro in parallel

If the Rotavapor is to be controlled from outside a fume hood, there is the option of connecting two separate interface units in parallel. In that case, distillation can be controlled from either interface unit. The readings displayed are continuously synchronized. The servicing functions (e.g. leak test) are controlled by the interface unit that is currently being used.

If a mobile connection (see Mobile connection) is desired when the I-300 and I-300 Pro are operating in parallel, the LAN cable must only be connected to one of the interface units, preferably the I-300 Pro.

- ▶ Connect the remote interface unit to the interface unit on the Rotavapor using the standard BUCHI communication port (COM). Use a standard BUCHI communication cable to do so.

6 Operation

6.1 Navigating the menu

The I-300 Pro offers the fundamental option of navigating the menu either by using the function buttons and the navigation control or by means of the touch-screen functionality of the display.

The touch-screen functions can be operated using laboratory gloves. Liquids on the screen do not pose a problem either and do not impair functionality in any way.

6.1.1 Selecting menu items

Selecting menu items on the touch-screen

All menu items can be selected directly on the touch-screen display.

- ▶ To open the main menu and select a menu item from the main menu, simply tap the desired symbol.

The selected menu icon is highlighted in green.

- ▶ To select a menu item from the submenu, tap the desired menu item.

On some submenus, the list of menu items is too long to be shown on the display all at once. In that case, a scroll bar appears on the right.

- ▶ To scroll down to a menu item on a submenu, slowly swipe the screen upwards with your finger.

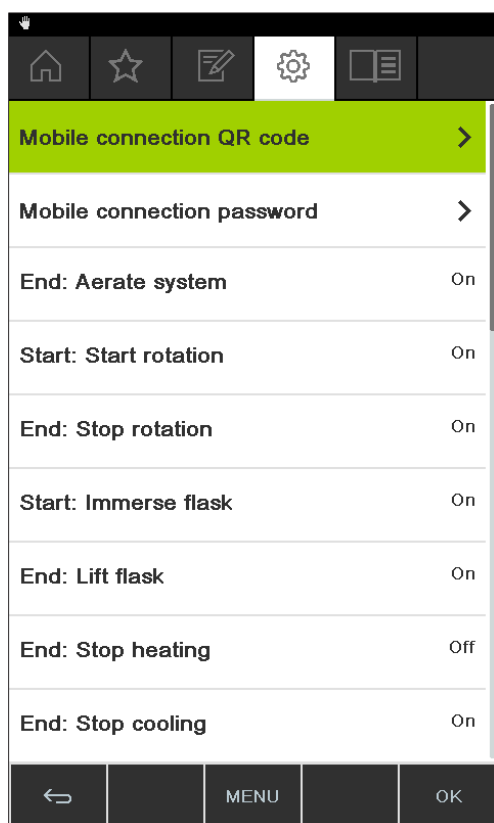

Fig. 20: Submenu with large number of items and scroll bar

Selecting menu items using the navigation control and function buttons

As an alternative to tapping the touch-screen display, menu items can also be selected using the navigation control and the function buttons. The home screen is the starting point. Rotating the navigation control selects each symbol in turn. The currently selected menu icon is highlighted in green.

- ▶ To open the main menu, press the MENU function button.

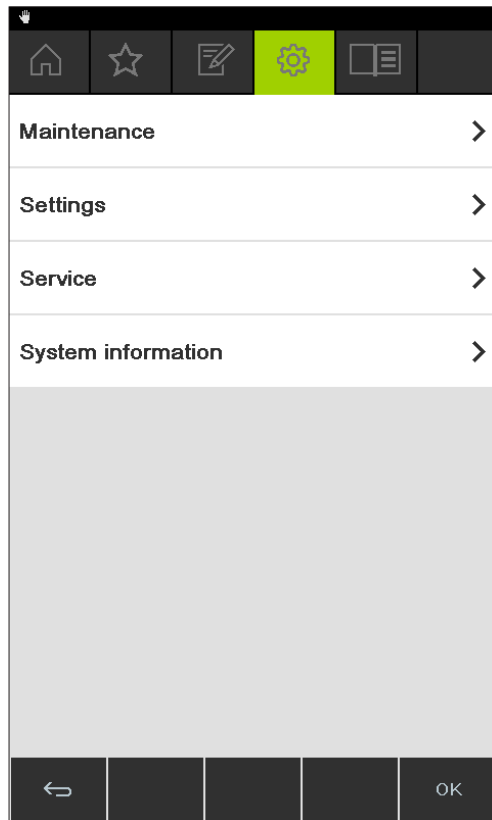

Fig. 21: Opening the menu on the Interface I-300 Pro

- ▶ To select a menu item from the main menu, turn the navigation control until the desired icon is highlighted in green.
- ▶ Press the navigation control to choose OK and confirm the selection.
- The display shows the desired submenu.

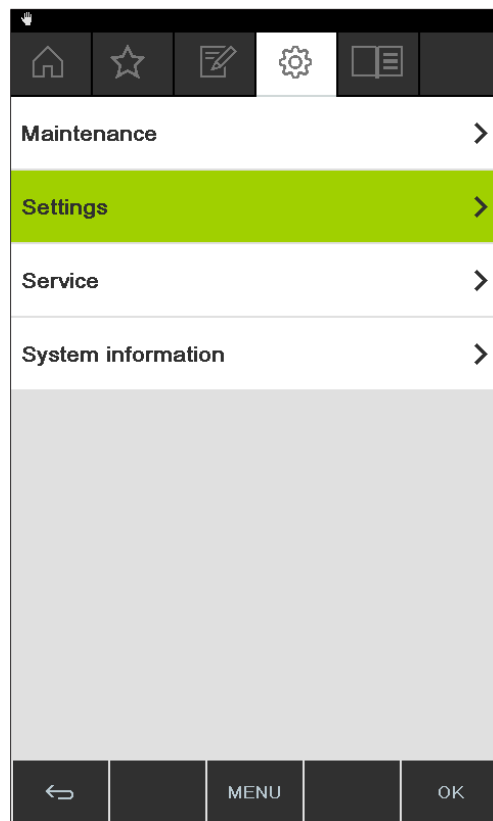



Fig. 22: Submenu

- ▶ To select a menu item from the submenu, turn the navigation control until the desired item is highlighted in green.
- ▶ Press the navigation control to choose OK and confirm the selection.
- The display shows the desired submenu on the next menu level down.
- ▶ To return to the previous menu level, press the function button .
- ▶ To return to the main menu, press the MENU function button.

6.1.2 Entering parameter settings

The Interface I-300 Pro offers the facility for manually setting various parameters. The parameters are shown on the home screen of the Interface I-300 Pro. The individual parameters are selected by rotating the navigation control or tapping the item directly on the screen. The currently selected parameter is highlighted in green.

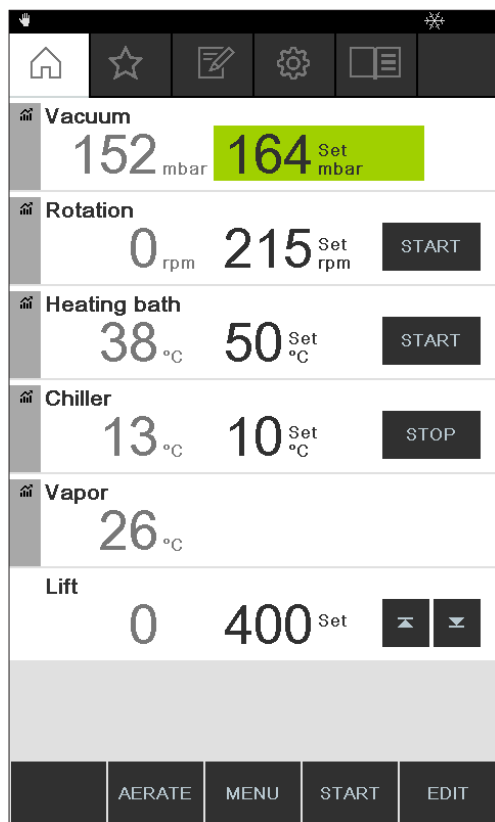

Fig. 23: Entering the settings

- Turn the navigation control to select the desired parameter, then press the navigation control to confirm the selection and choose EDIT. Alternatively, tap the parameter directly on the screen. The selected figure is shown in inverse type and the word "Set" flashes.

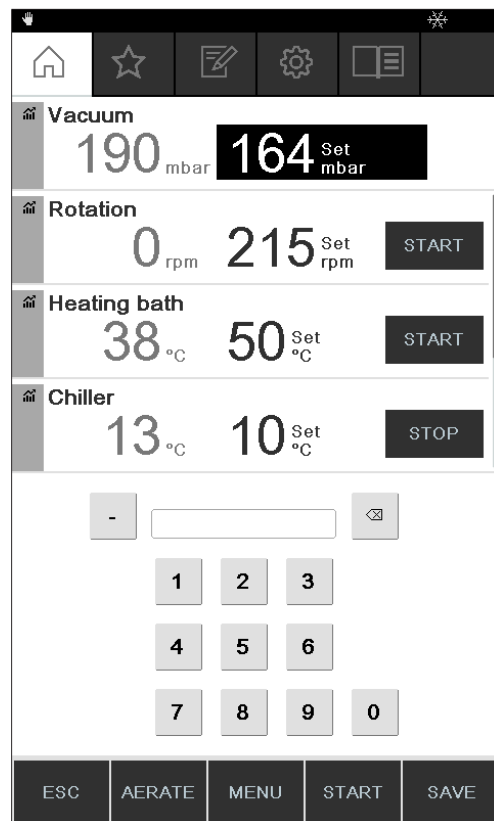

Fig. 24: Changing the setting

- ▶ To increase or decrease the figure, turn the navigation control clockwise or counter-clockwise. Alternatively, enter the figure using the keyboard.
- ▶ To save the new setting, press the navigation control to choose SAVE or tap SAVE directly on the screen.
- The new parameter setting is shown highlighted in green again.

If a reading graph is displayed (see Chapter 6.3 "Displaying reading graphs", page 84), not all parameters can be shown on the screen at once. In that case, a scroll bar appears on the screen.

- ▶ To scroll down to a parameter, turn the navigation control or slowly swipe the screen upwards with your finger.

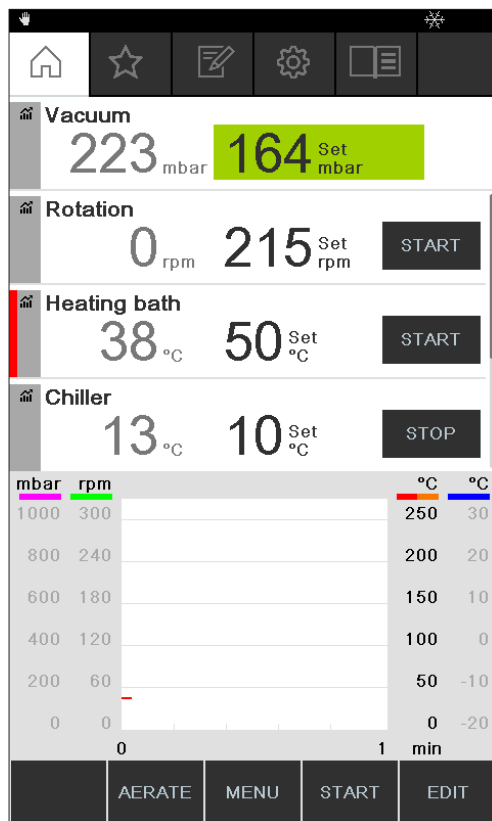

Fig. 25: Scrolling on home screen

6.1.3 Changing settings

The Interface I-300 Pro offers the facility for manually entering various settings.

- ▶ Use the navigation control or tap the screen to select the desired setting, see Selecting menu items.
- ▶ To edit the setting, press the navigation control to choose EDIT or directly tap EDIT on the screen.
The options for the setting are shown.
- ▶ To select an option, turn the navigation control or tap the option directly on the screen. A green bar appears next to the selected option.

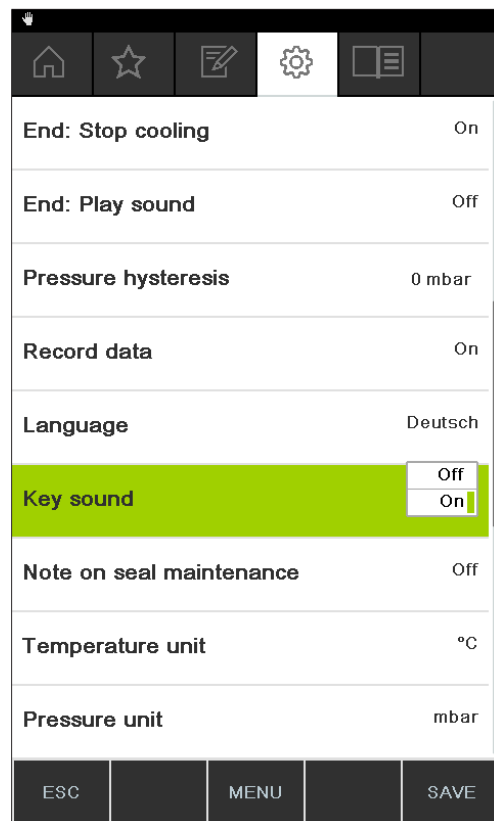





Fig. 26: Options for a setting

- ▶ To save the new option for the setting, press the navigation control to choose SAVE or tap SAVE directly on the screen.

6.2 Performing distillation

The Interface I-300 Pro offers the following options for performing distillation:



- **Manual**  For performing manual distillation, see Chapter 6.2.4 "Performing manual distillation", page 59.
- **Timer**  For performing timer-controlled distillation, see Chapter 6.2.5 "Performing timer-controlled distillation", page 63.
- **Drying**  For drying the product, see Chapter 6.2.8 "Drying the product", page 75.



NOTE

Drying not available with R-220 Pro:

The operating mode "Drying" is not available if the Interface I-300 Pro is operated with the Rotavapor R-220 Pro.

- **AutoDest**  For performing automatic distillation, see Chapter 6.2.7 "Performing automatic distillation", page 72.
- **Continuous pumping**  For drying the system after distillation, see Chapter 6.2.6 "Drying the system after distillation ("Continuous pumping")", page 69.
- **Methods**  For carrying out distillation according to a defined method, Chapter 6.2.9 "Methods", page 78.

6.2.1 Overview: typical distillation sequence

Proper performance of a distillation process typically requires the following steps in the order indicated.



NOTE

The steps listed below in "Starting distillation" and "Stopping distillation" can also be pre-programmed via the interface unit, see Configuration.

Starting distillation



Step	Component	Action
1	Heating bath	Set the required temperature and start the heating bath.
2	Recirculating chiller	Set the required temperature and start the recirculating chiller.
3	Rotavapor	Start rotation at a slow speed.
4	Vacuum pump	Set the required pressure and start the vacuum pump.
5	Rotavapor	Immerse the evaporating flask in the heating bath.
6	Rotavapor	Increase rotation to the desired speed.



NOTE

The heating bath, rotary drive unit and the recirculating chiller can either be started on the devices themselves or on the home screen of the interface unit using the direct intervention buttons, see Chapter 3.4.5 "Display", page 18.

Stopping distillation



Step	Component	Action
1	Vacuum pump/Valve unit	Stop pressure regulation.
2	Interface unit Rotavapor	Vent the system (AERATE). Vent the system (open glass stopcock, open cooling condenser).
3	Rotavapor	Reduce rotation speed.
4	Rotavapor	Lift evaporating flask out of heating bath.
5	Rotavapor	Stop rotation.
6	Heating bath	Stop heating.
7	Interface unit Recirculating chiller	Stop cooling ( OFF). Stop cooling.

6.2.2 Basic functions

Venting during distillation

There is the possibility to briefly venting the system while distillation is in progress.

- ▶ To briefly vent the system while distillation is in progress, press and hold the AERATE function button until the desired pressure is reached.
While venting is active, the status bar is shown in yellow on the display.

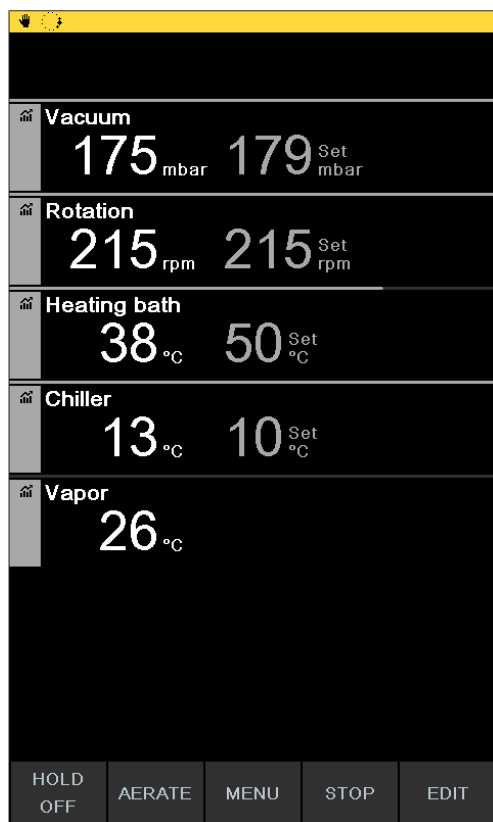

Fig. 27: Home screen during venting

- ▶ To evacuate the system to the specified vacuum again after venting, press the function button HOLD OFF.

Venting after completion of distillation

If venting has not been pre-programmed on the interface unit, the system can be fully vented manually after completion of the distillation process.

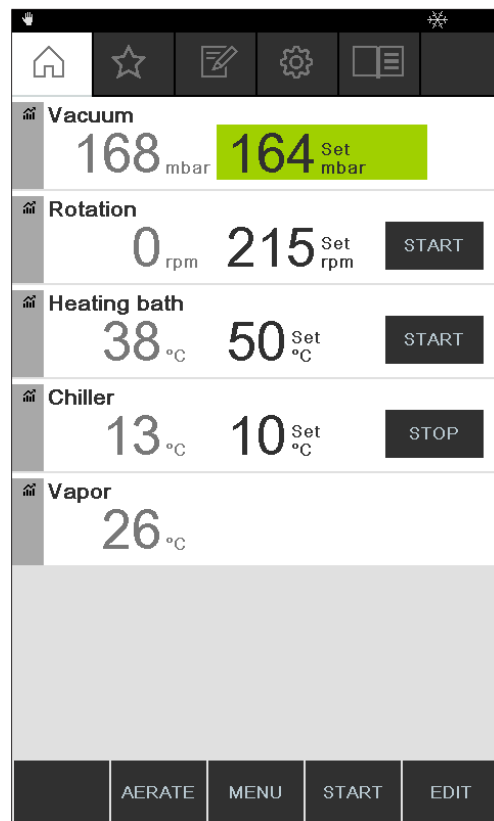

Fig. 28: Home screen after completion of distillation

► After completion of distillation, press the AERATE function button.

The system is vented until it reaches ambient pressure.

Manually stopping the cooling process

The cooling function continues after completion of a distillation process. If the system has been pre-programmed accordingly, the cooling process stops after 5 minutes.

While cooling is active, the status bar shows the symbol ❄️. The cooling process can be stopped manually at any time regardless of how the system has been pre-programmed.

Precondition:

After completion of distillation, the system has been fully vented by pressing the AERATE function button.

► To manually stop the cooling process, press the function button ❄️ OFF.

The cooling process is stopped and the cooling symbol disappears from the status bar.

Stopping everything

There is the possibility to immediately stopping all apparatus connected to the system while distillation is in progress.

► To stop all apparatus immediately, press the red STOP button (emergency stop).

6.2.3 Controlling lift position via the interface unit

The rotary drive unit of the Rotavapor R-300 can be raised or lowered using the lift control function on the interface unit. To be able to control the lift position using the interface unit, a depth stop has to be set. For details, refer to the Rotavapor operating instructions. The home screen of the interface unit then shows the parameter "Lift" together with the actual position and the depth stop setting. If the rotary drive unit is lowered into the heating bath as far as the depth stop, the actual position is the same as the selected setting.



NOTE

With the Rotavapor R-300, the lift position can be controlled by an Interface I-300/ I-300 Pro.

With the Rotavapor R-220 Pro, the interface display does not show the current lift position.

Using the interface unit, the lift position can either be fully lowered as far as the depth stop or fully raised.

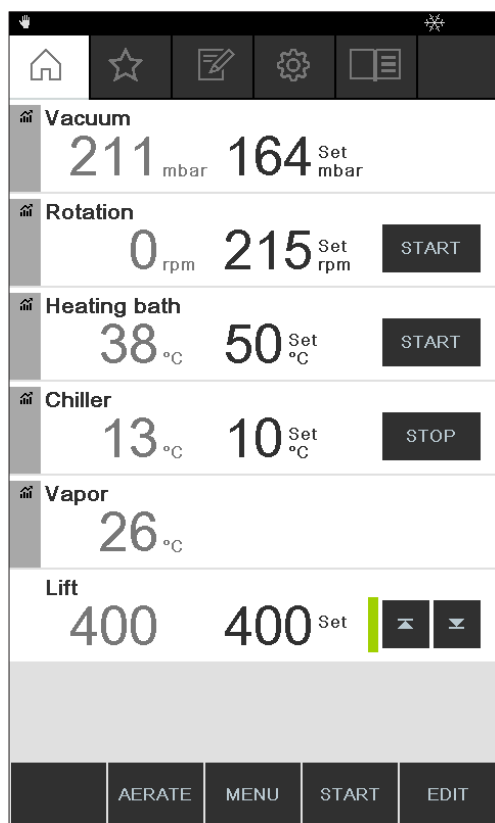

Fig. 29: Lift position: rotary drive unit lowered

- ▶ To lower the rotary drive unit into the heating bath, press the Down arrow button.
CAUTION! Risk of pinching injuries. If using the protection shield, make sure that your fingers or other parts of the body are not trapped.
The rotary drive unit is lowered as far as the depth stop.
- ▶ To raise the rotary drive unit out of the heating bath, press the Up arrow button.
The rotary drive unit is raised fully out of the heating bath.

6.2.4 Performing manual distillation

In "Manual" operating mode (manual distillation), the distillation process can be controlled by manually setting the individual process parameters.



CAUTION

Risk of personal injury and property damage from unexpected equipment behavior

- ▶ Always carefully check the pre-programmed settings before every distillation process. In particular, check the setting for immersion of the evaporating flask at the start of the distillation process.

Navigation path

→ Operating modes → Manual

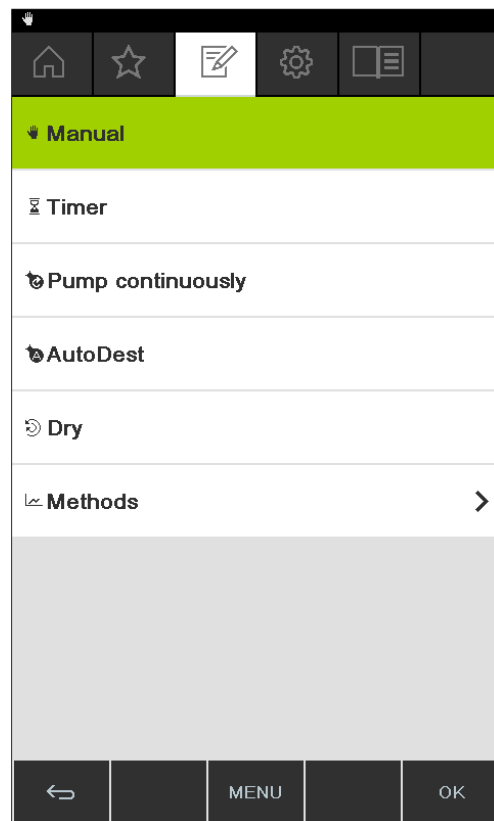

Fig. 30: Selecting "Manual distillation" on the "Operating modes" screen

- ▶ Navigate to the "Operating modes" screen and select the menu item "Manual", see Navigating the menu.
The display shows the home screen with the symbol for manual distillation in the status bar.

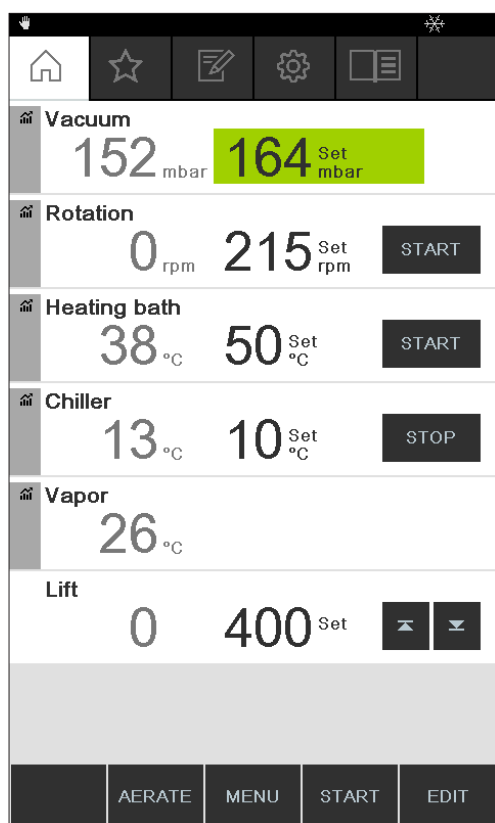

Fig. 31: Home screen showing "Manual" symbol

- ▶ Enter the required settings for the process parameters.

In this operating mode, the following parameters and readings are available:

Parameters and readings	Equipment possibly required
<ul style="list-style-type: none"> Specified setting for vacuum Actual reading for current pressure in distillation system 	VacuBox (e.g. with Vacuum Pump V-300/V-600)
<ul style="list-style-type: none"> Actual reading and specified setting for rotation speed (evaporating flask) 	Rotavapor R-300
<ul style="list-style-type: none"> Actual reading and specified setting for heating bath temperature 	Heating Bath B-301/B-305
<ul style="list-style-type: none"> Actual reading and specified setting for cooling temperature 	Recirculating Chiller F-3xx
<ul style="list-style-type: none"> Actual reading for vapor temperature 	AutoDest sensor or vapor temperature sensor
<ul style="list-style-type: none"> Actual reading for lift 	

Starting manual distillation

Precondition:

Process parameters have been set.

▶ Press the function button START.

The display shows the home screen in inverse type.

The status bar shows the symbol  for distillation in progress.

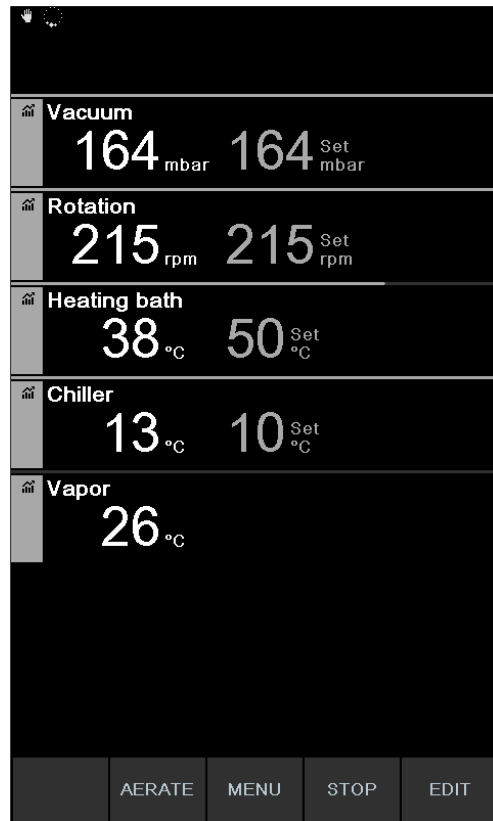

Fig. 32: Distillation process started

The actual readings are shown more brightly in the left-hand column of the display. The right-hand column shows the specified settings.

▶ To abort the cooling process prematurely, press the function button STOP.

Editing parameters during manual distillation

There is the facility for changing individual parameter settings while distillation is in progress.

Precondition:

- Distillation process has been started.
- ▶ Select the parameter that is to be adjusted while distillation is in progress, see Chapter 6.1 "Navigating the menu", page 47.
The display shows the selected parameter setting highlighted in inverse type.



Fig. 33: Editing parameters while distillation is in progress

- ▶ Raise or lower the selected parameter setting.
While the parameters are being edited, the distillation process continues running in the background (identifiable by the  symbol on the status bar).
- After the parameter setting has been altered, the display shows the home screen in inverse type with the current readings displayed more brightly.

Stopping manual distillation

- ▶ To stop the distillation process, press the function button STOP.
- The display shows the home screen with the current readings and specified settings. The status bar shows the cooling symbol, if applicable, together with a timer that is counting down.

6.2.5 Performing timer-controlled distillation

In "Timer" mode, a distillation process with a predefined duration is started.



CAUTION

Risk of personal injury and property damage from unexpected equipment behavior

- ▶ Always carefully check the pre-programmed settings before every distillation process. In particular, check the setting for immersion of the evaporating flask at the start of the distillation process.

Navigation path

→ Operating modes → Timer

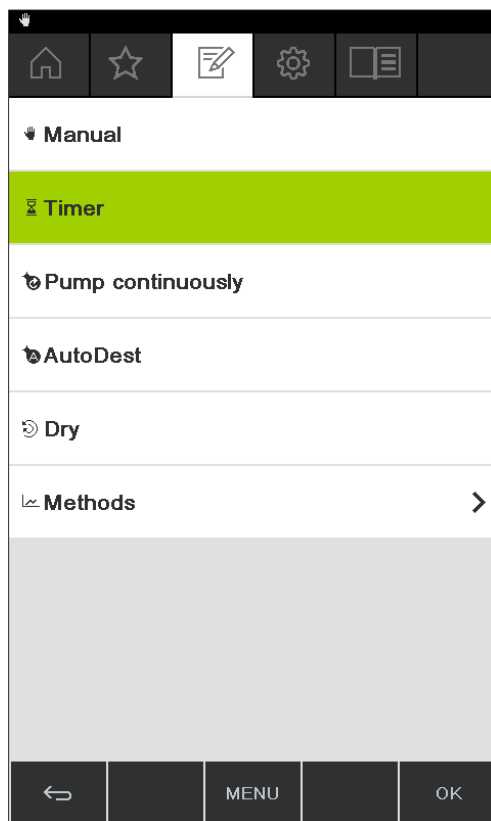

Fig. 34: Selecting "Timer" on the submenu "Operating modes"

- ▶ Navigate to the "Operating modes" screen and select the menu item "Timer", see Chapter 6.1 "Navigating the menu", page 47.
- The display shows the home screen with the symbol for timer-controlled distillation in the status bar.

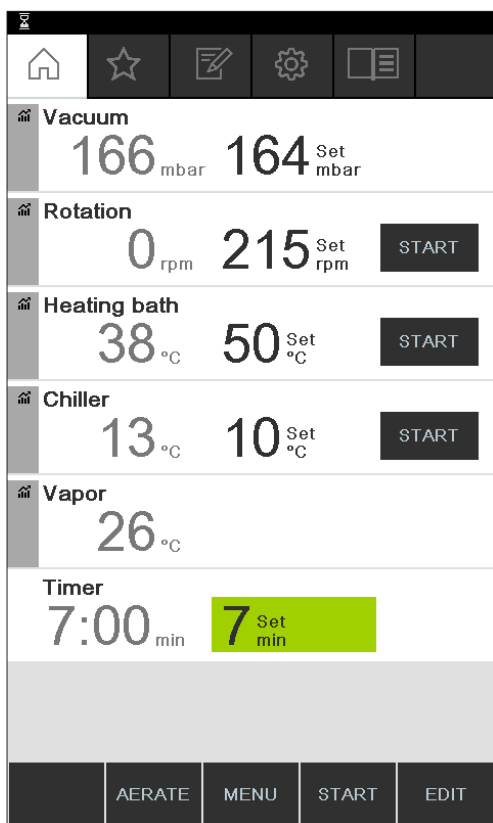

Fig. 35: "Timer" screen showing timer setting highlighted in green

- ▶ Set the time period after which distillation is to be automatically stopped.
- ▶ Select and edit other parameters as necessary.

In this operating mode, the following parameters and readings are available:

Parameters and readings	Equipment possibly required
<ul style="list-style-type: none"> • Specified setting for vacuum • Actual reading for current pressure in distillation system 	VacuBox (e.g. with Vacuum Pump V-300/V-600)
<ul style="list-style-type: none"> • Actual reading and specified setting for rotation speed (evaporating flask) 	Rotavapor R-300
<ul style="list-style-type: none"> • Actual reading and specified setting for heating bath temperature 	Heating Bath B-301/B-305
<ul style="list-style-type: none"> • Actual reading and specified setting for cooling temperature 	Recirculating Chiller F-3xx
<ul style="list-style-type: none"> • Actual reading for vapor temperature 	AutoDest sensor or vapor temperature sensor
<ul style="list-style-type: none"> • Actual reading and specified setting for duration of distillation (timer) 	
<ul style="list-style-type: none"> • Actual reading for lift 	

Starting timer-controlled distillation

Precondition:

- Timer and process parameters have been set.

► Press the function button START.



Fig. 36: "Timer" screen while distillation is in progress

- The display shows the home screen in inverse type with the symbol for timer-controlled distillation in the status bar. The actual readings for the timer and the other parameters are shown in the left-hand column of the display. The right-hand column shows the corresponding specified settings.

Editing timer and parameter settings while distillation is in progress

There is the facility for changing the timer setting and other parameters while timer-controlled distillation is in progress.

Precondition:

- Timer-controlled distillation process has been started.



Fig. 37: Editing parameters while distillation is in progress

- ▶ Enter the new setting for the timer.
While the parameters are being edited, the distillation process continues running in the background (identifiable by the  symbol on the status bar).



Fig. 38: Saving edited parameter settings

After the parameters have been altered, the timer jumps to the new setting and starts counting down the time from the beginning. The progress bar in the status bar jumps back to the beginning.

- ▶ Edit other parameters as necessary.

Stopping timer-controlled distillation

The timer-controlled distillation process stops automatically when the preset time has elapsed. After completion of timer-controlled distillation, an audible signal consisting of three beeps sounds at regular intervals if the corresponding option has been set on the Configuration menu.



NOTE

The audible signal is canceled as soon as the next user action is registered.

There is the facility for stopping distillation before the set time has elapsed.

- ▶ To stop the timer-controlled distillation process prematurely, press the function button STOP.
- On completion of timer-controlled distillation, the display shows the following information:

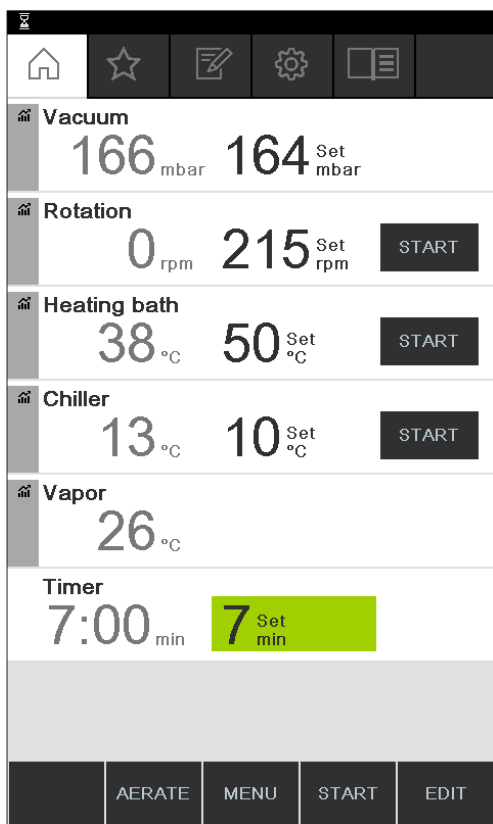

Fig. 39: "Timer" screen after completion of distillation

6.2.6 Drying the system after distillation ("Continuous pumping")

In "Continuous pumping" mode, the system continues running in "idling" mode to dry out the vessels and tubing after a distillation process has finished.



NOTE

In "Continuous pumping" mode, the settings for manual or timer-controlled distillation are ignored. The heating bath does not automatically switch on and the lift does not automatically lower, etc.

Navigation path

→ Operating modes → Continuous pumping

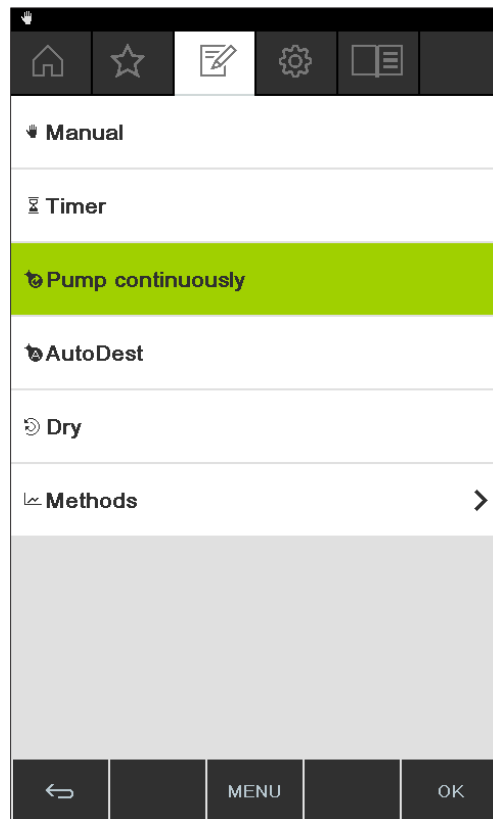

Fig. 40: Selecting "Continuous pumping" on the "Operating modes" screen

- ▶ Navigate to the "Operating modes" screen and select the menu item "Continuous pumping", see Navigating the menu.
The display shows the home screen with the symbol for continuous pumping in the status bar.

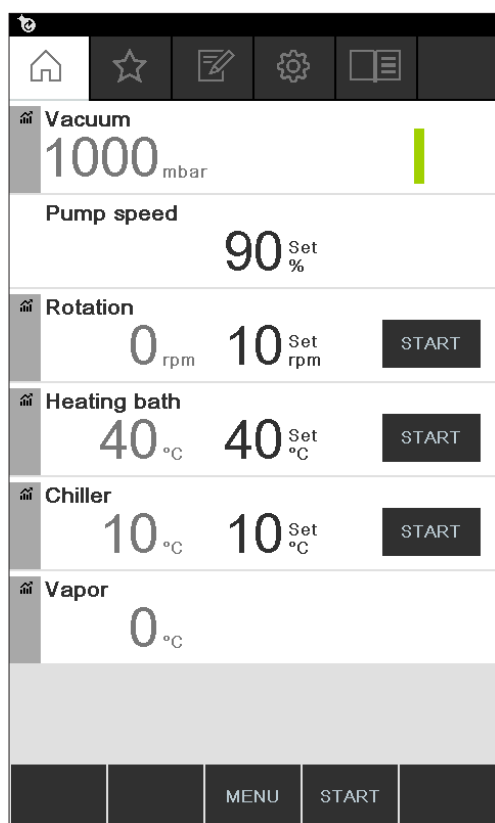

Fig. 41: "Continuous pumping" screen

**NOTE**

In "Continuous pumping" mode, only the following parameters can be edited: Rotation (rotation speed of the evaporating flask), Heating bath (temperature) and Recirculating chiller (temperature). Those processes cannot be started via the interface unit and instead have to be started manually on the equipment concerned.

- ▶ Select and edit the settings for individual process parameters as necessary.
- ▶ Press the function button START to start the drying process ("Continuous pumping").
The drying process continues running until it is stopped manually.



Fig. 42: Continuous pumping for drying the system started

- ▶ To edit individual process parameters (e.g. rotation) while drying is in progress, select and edit the parameter concerned in each case.
- ▶ To stop the drying process, press the function button STOP.

In this operating mode, the following parameters and readings are available:

Parameters and readings	Equipment possibly required
<ul style="list-style-type: none"> • Actual reading for current pressure in distillation system 	VacuBox (e.g. with Vacuum Pump V-300/V-600)
<ul style="list-style-type: none"> • Specified setting for maximum pump speed 	VacuBox (e.g. with Vacuum Pump V-300/V-600)
<ul style="list-style-type: none"> • Actual reading and specified setting for rotation speed (evaporating flask) 	Rotavapor R-300
<ul style="list-style-type: none"> • Actual reading and specified setting for heating bath temperature 	Heating Bath B-301/B-305
<ul style="list-style-type: none"> • Actual reading and specified setting for cooling temperature 	Recirculating Chiller F-3xx
<ul style="list-style-type: none"> • Actual reading for vapor temperature 	AutoDest sensor or vapor temperature sensor
<ul style="list-style-type: none"> • Actual reading for lift 	



NOTE

The pressure (vacuum) cannot be altered. The vacuum pump runs at the maximum speed setting.

6.2.7 Performing automatic distillation

Automatic distillation requires the use of an AutoDest sensor. The AutoDest sensor is connected to the VacuBox (see Chapter 5.3 "Connecting AutoDest sensor to vapor temperature sensor (optional accessory)", page 42) and measures the inlet and outlet temperature of the coolant and the vapor temperature at the cooling condenser. From those three readings, the system calculates the parameter settings required for optimum distillation. During automatic distillation, the temperatures of the heating bath, coolant and vapor are constantly measured and the specified setting for the pressure adjusted accordingly.



CAUTION

Risk of personal injury and property damage from unexpected equipment behavior

- ▶ Always carefully check the pre-programmed settings before every distillation process, see the section headed "Distillation". In particular, check the setting for immersion of the evaporating flask at the start of the distillation process.

Navigation

→ Operating modes → AutoDest

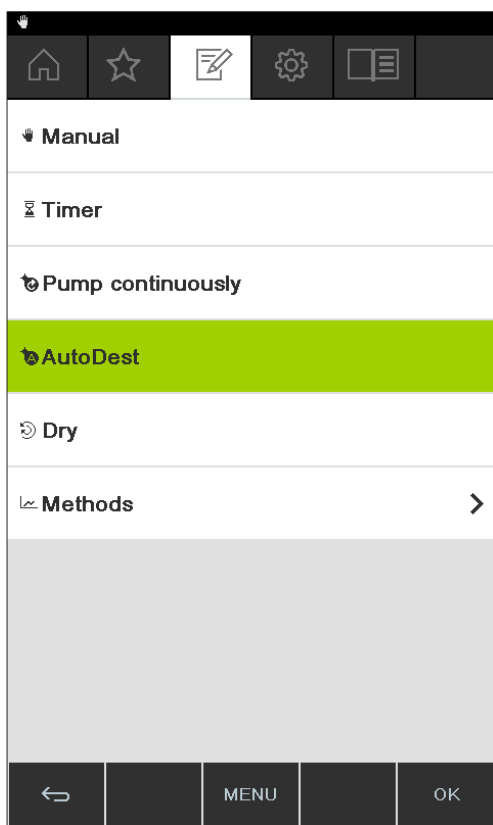

Fig. 43: Selecting "AutoDest" on the submenu "Operating modes"

Precondition:

- An AutoDest sensor has been installed and calibrated, see Chapter 8.5 "Calibrating AutoDest sensor", page 115.

- Navigate to the "Operating modes" screen and select the menu item "AutoDest", see Navigating the menu.
The display shows the home screen with the symbol for automatic distillation in the status bar.

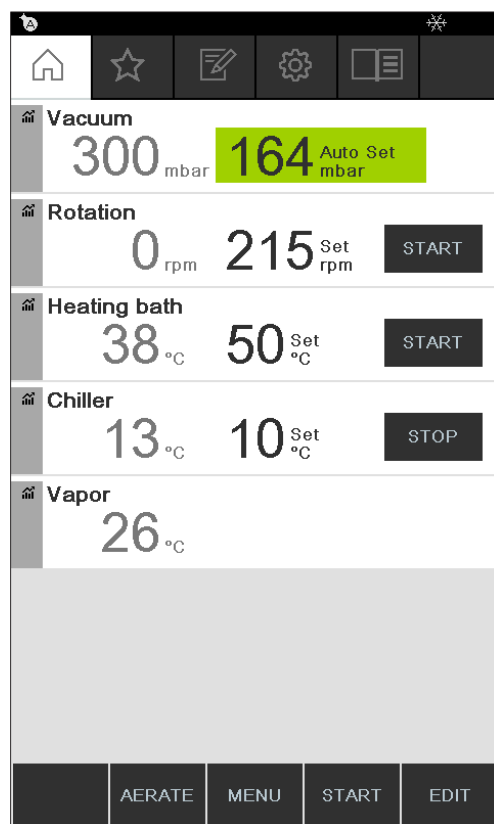

Fig. 44: Home screen showing "AutoDest" symbol

- Select and edit the required settings for individual process parameters as necessary. When doing so, make sure that the temperatures for heating bath and coolant are set so as to be 40 °C apart.

In this operating mode, the following parameters and readings are available:

Parameters and readings	Equipment possibly required
<ul style="list-style-type: none"> Specified setting for vacuum Actual reading for current pressure in distillation system 	VacuBox (e.g. with Vacuum Pump V-300/V-600)
<ul style="list-style-type: none"> Actual reading and specified setting for rotation speed (evaporating flask) 	Rotavapor R-300
<ul style="list-style-type: none"> Actual reading and specified setting for heating bath temperature 	Heating Bath B-301/B-305
<ul style="list-style-type: none"> Actual reading and specified setting for cooling temperature 	Recirculating Chiller F-3xx
<ul style="list-style-type: none"> Actual reading for vapor temperature 	AutoDest sensor or vapor temperature sensor
<ul style="list-style-type: none"> Actual reading for lift 	

Starting automatic distillation

Precondition:

Process parameters have been set.

► Press the function button START.



Fig. 45: Information displayed during automatic distillation

- The display shows the home screen in inverse type.
- The status bar shows the symbol  for distillation in progress.

Editing parameters during automatic distillation

There is the facility for altering the process parameters while automatic distillation is in progress, see Chapter "Editing parameters during manual distillation", page 62.



NOTE

If the specified setting for the pressure is altered manually, the level set automatically is lost and the operating mode switches to manual distillation.



NOTE

The specified settings for the individual parameters may only be altered gradually, otherwise distillation may be aborted.

Stopping automatic distillation



NOTE

The automatic distillation process stops automatically as soon as the solvent in the evaporating flask has evaporated.

After completion of automatic distillation, an audible signal consisting of three beeps sounds at regular intervals if the corresponding option has been set on the Configuration menu.

There is the facility for stopping distillation prematurely.

- ▶ To stop the automatic distillation process prematurely, press the function button STOP.
- The display shows the home screen with the current readings and specified settings. The status bar shows the cooling symbol, if applicable, together with a timer that is counting down.

6.2.8 Drying the product

In "Drying" mode, the remaining product in the evaporating flask is gently dried after completion of a distillation process. For this purpose, the evaporating flask on the Rotavapor R-300 rotates in alternating directions at defined intervals (e.g. 5 seconds).



NOTE

Drying not available with R-220 Pro:

The operating mode "Drying" is not available if the Interface I-300 Pro is operated with the Rotavapor R-220 Pro.

Navigation path

→ Operating modes → Drying

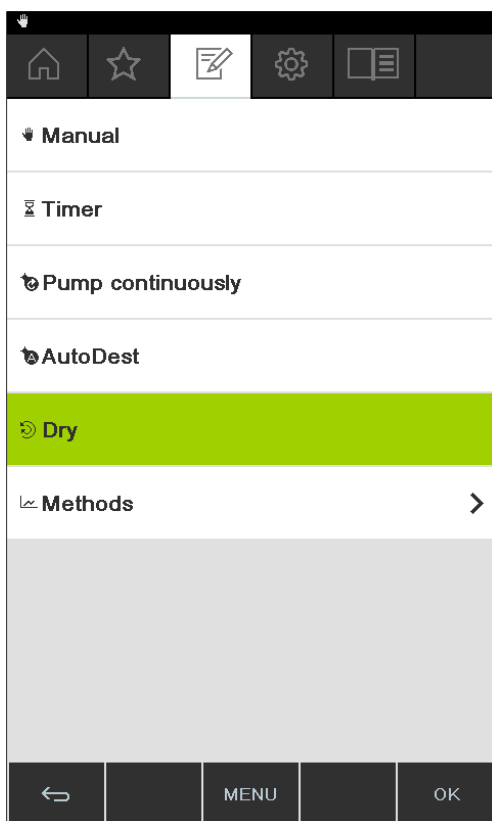

Fig. 46: Selecting "Drying" on the "Operating modes" screen

- ▶ Navigate to the "Operating modes" screen and select the menu item "Drying", see Navigating the menu.

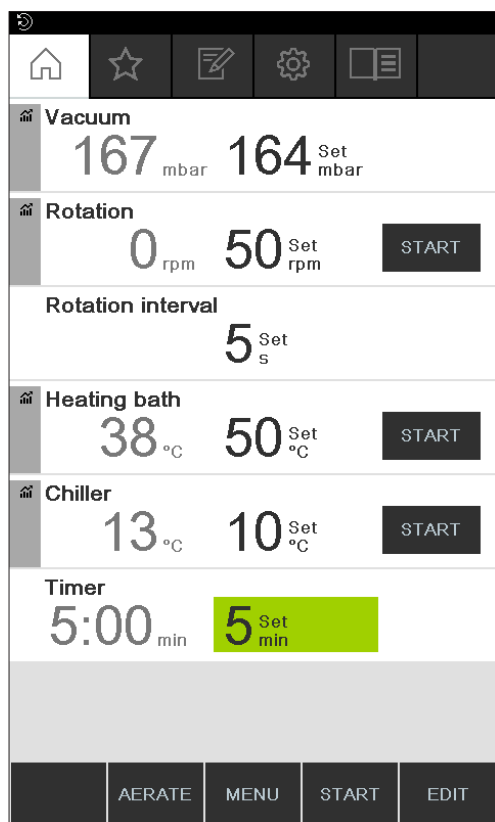

Fig. 47: Home screen showing "Drying" symbol

- The display shows the home screen with the symbol for automatic drying in the status bar.



NOTE

Timer and rotation interval: the timer sets the duration of the complete drying process. The rotation interval specifies the period of time that the evaporating flask rotates in each direction.

In this operating mode, the rotation speed is limited to 150 rpm.

- ▶ Set the desired rotation interval for the evaporating flask by means of the process parameter "Rotation interval".
- ▶ Set the desired length of the drying process by means of the process parameter "Timer".
- ▶ To start the process for drying the product, press the function button START.
- The process stops automatically when the preset time has elapsed.

In this operating mode, the following parameters and readings are available:

Parameters and readings	Equipment possibly required
<ul style="list-style-type: none"> • Specified setting for vacuum • Actual reading for current pressure in distillation system 	VacuBox (e.g. with Vacuum Pump V-300/V-600)
<ul style="list-style-type: none"> • Actual reading and specified setting for rotation speed (evaporating flask) • Specified setting for rotation interval 	Rotavapor R-300

Parameters and readings	Equipment possibly required
<ul style="list-style-type: none">• Actual reading and specified setting for heating bath temperature	Heating Bath B-301/B-305
<ul style="list-style-type: none">• Actual reading and specified setting for cooling temperature	Recirculating Chiller F-3xx
<ul style="list-style-type: none">• Actual reading for vapor temperature	AutoDest sensor or vapor temperature sensor
<ul style="list-style-type: none">• Actual reading and specified setting for duration of drying process (timer)	Rotavapor R-300 "Drying" mode is not available with R-220 Pro.
<ul style="list-style-type: none">• Actual reading for lift	Rotavapor R-300 Display of lift position is not available for Rotavapor R-220 Pro.

6.2.9 Methods

The Interface I-300 Pro provides the facility for programming a sequence of up to 12 steps with defined times and parameters. Up to 30 methods can be created. In Methods operating mode, automatic distillation is not possible.

The following steps can be programmed:

Step	Possible settings
Gradient	<p>In this mode, the following process parameters can be defined:</p> <ul style="list-style-type: none"> • Initial vacuum • Terminal vacuum • Timer • Rotation • Heating bath • Recirculating chiller <p>The initial and terminal vacuum settings can be identical, e.g. to prevent foam formation with natural products. Alternatively, the foam sensor can be used.</p>
Pause	<p>A message can be selected that is to be displayed when the previous step is stopped:</p> <ul style="list-style-type: none"> • Removing the receiving flask • Removing the evaporating flask • Clean condenser • Fit bath cover • Clean system • Fit receiving flask • Fit dry receiving flask • Replenish solvent • Transfer contents to drying flask • Fit dry evaporating flask <p>The messages may also be displayed on the BUCHI Connect Solution, see Chapter 7 "Mobile connection", page 97.</p> <p>The subsequent step has to be started manually.</p>
Drying (only with Rotavapor R-300)	<ul style="list-style-type: none"> • Vacuum • Rotation • Heating bath • Recirculating chiller • Timer • Rotation interval

Example

- Step 1: **Gradient**. 300 mbar.
- Step 2: **Pause**. Message "Fit dry receiving flask".
- Step 3: **Drying**. 150 rpm, 5 minutes.

Creating a method

Navigation path

→ Operating modes → Methods

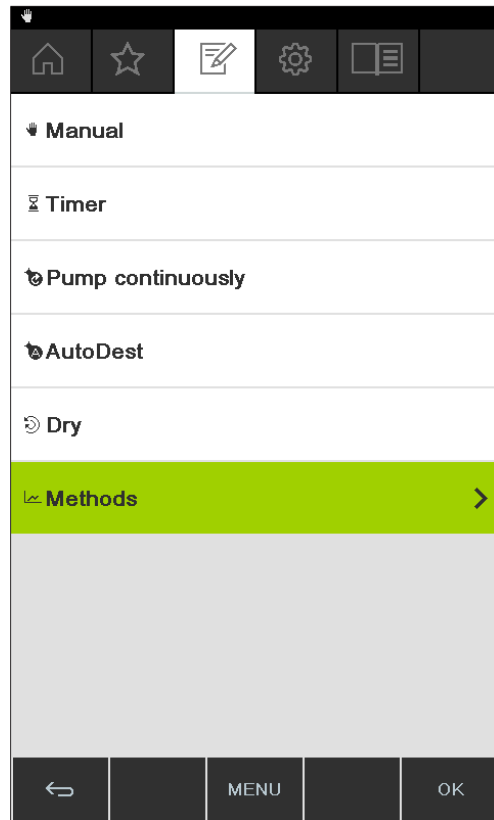

Fig. 48: Menu item "Methods" on "Operating modes" menu

- ▶ Navigate to the "Operating modes" screen and select the menu item "Methods", see Chapter 6.1 "Navigating the menu", page 47.

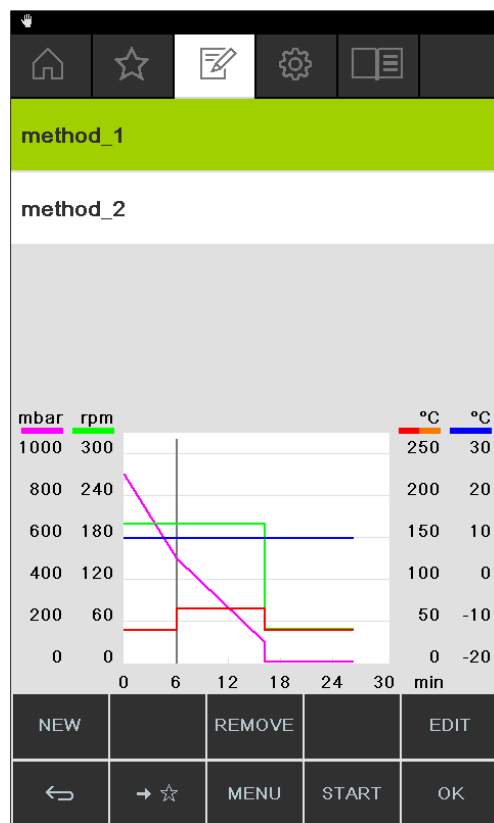

Fig. 49: Creating a new method

- ▶ To create a new method, press NEW.

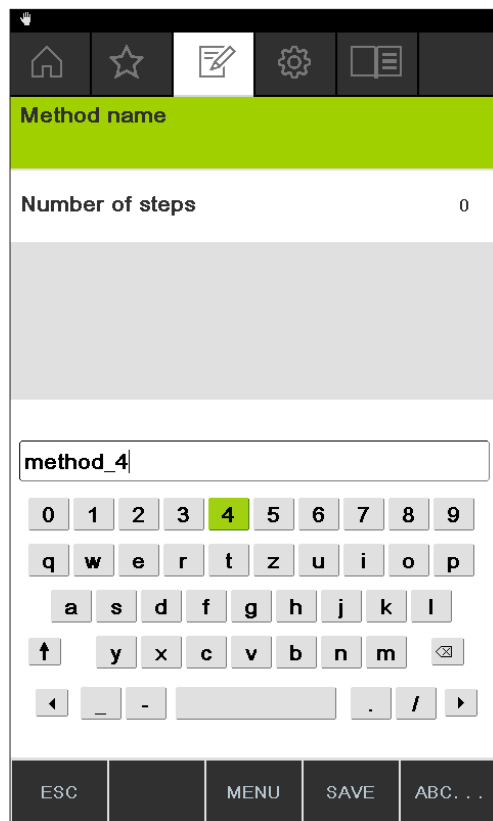

Fig. 50: Entering a method name

- ▶ To give the method a name, select the menu item "Method name".
- ▶ Use the keyboard to enter a name for the method and press SAVE to save it.

Defining the method

- ▶ Select the menu item "Number of steps" and specify the desired number of steps. The screen shows the individual steps.

Method name	Step
method_4	1 / 3
Function	Gradient
Vacuum start	900 mbar
Vacuum end	100 mbar
Timer	10 min
Rotation	200 rpm
Heating bath	40 °C
Chiller	10 °C

Fig. 51: Assigning a function and entering settings

- ▶ Select Step 1 to assign a function to it.
- ▶ Select the menu item "Function" and press EDIT to assign a function.
- ▶ Save the assigned function by pressing SAVE.
The possible settings for the function concerned appear.
- ▶ Enter the desired settings.
- ▶ Press SAVE STEP to save the edited step.
- ▶ Define all the other steps as described above and then save the method by choosing SAVE METHOD.



NOTE

Any of the settings for a method can be edited at any time, e.g. number of steps, assigned functions, etc.



NOTE

Drying not available with R-220 Pro:

The option "Drying" is not available if the Interface I-300 Pro is operated with the Rotavapor R-220 Pro.

Starting a method

Navigation path

→ Operating modes → Methods

Precondition:

A method has been created.

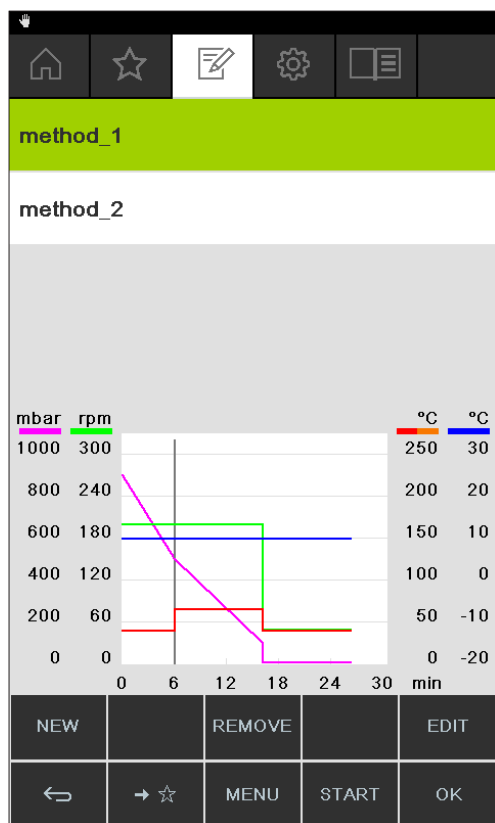

Fig. 52: Selecting a method



NOTE

Graph display of specified settings:

When the method is created and selected, the graph progression shows all specified settings of the programmed parameters. The specified settings are displayed across all programmed steps.

► Select a method and press START to start the distillation process immediately.

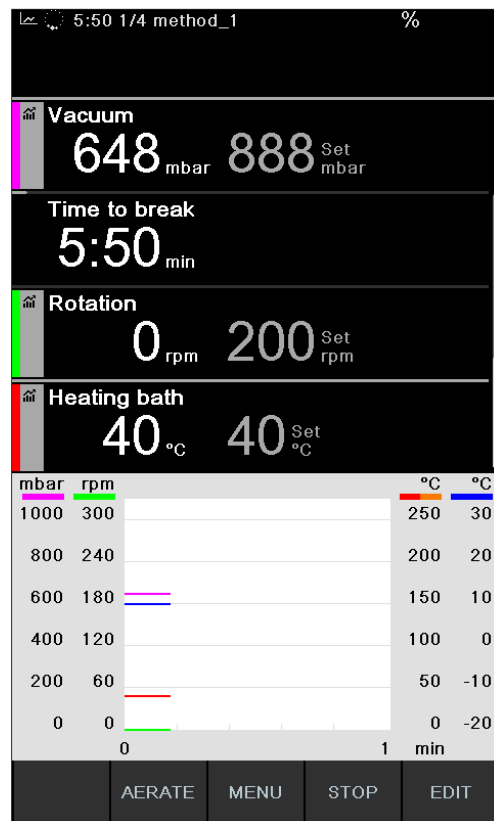



Fig. 53: Display while method is running

- The display shows the home screen in inverse type.
- The status bar shows the symbol  for distillation in progress and the symbol for "Methods".



NOTE

The status bar also indicates which step of the distillation process is currently in progress.



NOTE

Display of remaining time:
while a method is in progress, the display shows the remaining time until the next user intervention.

6.3 Displaying reading graphs

The Interface I-300 Pro offers the facility for displaying graphs of process data readings while distillation is in progress. You can individually select which process parameters are to be shown as graphs.

The following readings can be shown as graphs:

- Actual vacuum
- Actual rotation speed
- Actual heating bath temperature
- Actual recirculating chiller temperature
- Actual vapor temperature

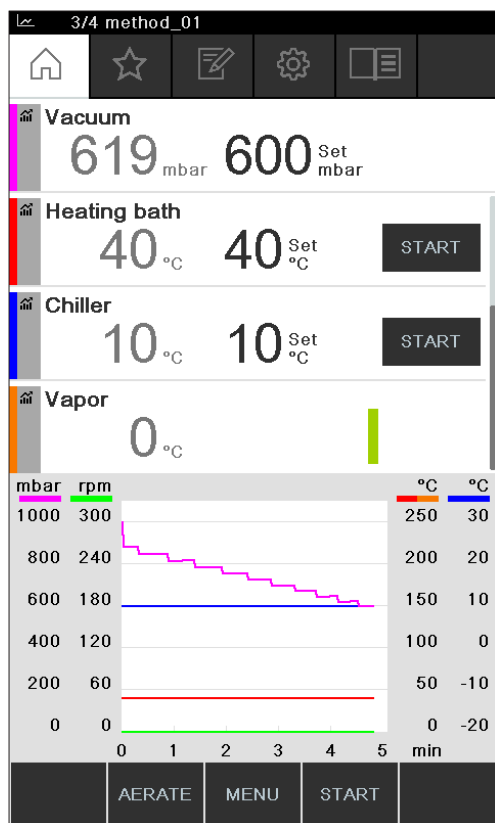

Fig. 54: Activating a graph

Precondition:

- The home screen is displayed.
- To display the reading graph for a process parameter, tap the gray icon on the left next to the parameter concerned (in this example, vacuum).
The icon changes color and the graph display appears.
- While distillation is in progress, the graph of each selected parameter is shown in the color matching the parameter concerned.

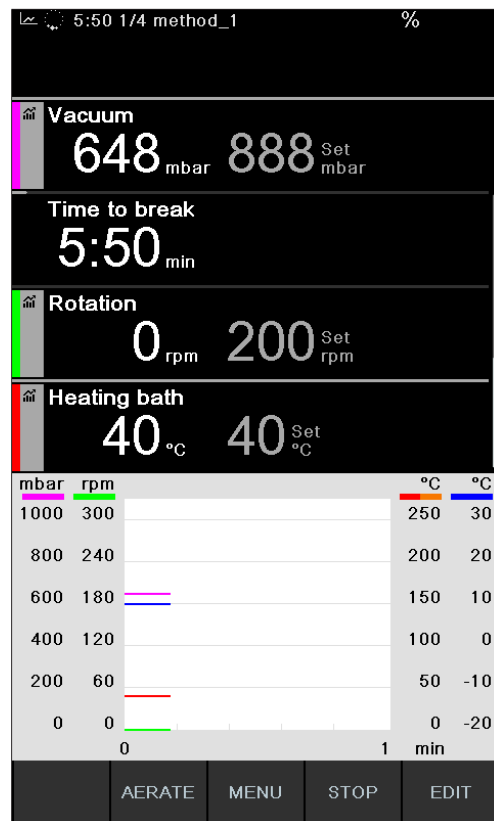

Fig. 55: Parameter reading graph during distillation



NOTE

The graphs can also be displayed during and after a distillation process. As soon as a new distillation process is started, the data from the previous process is lost.

6.4 Recording process data

The Interface I-300 Pro offers the facility for saving process data from a distillation process to an SD card.

The following process data is recorded:

- Actual and specified pressure
- Actual and specified rotation speed
- Actual and specified heating bath temperature
- Actual and specified recirculating chiller temperature
- Actual vapor temperature
- Events such as defoaming and AERATE
- Difference between inlet and outlet temperature at AutoDest sensor

The data is saved as a TXT file in CSV format. Recording starts every time a distillation process is started if the option has been set accordingly in the settings. The data records are identified by date and time (see Chapter 3.5.3 "Configuration", page 23). Management and deletion of the recorded data is the responsibility of the user.

```

Time s,Pressure actual mbar,Pressure set mbar,Bath actual °C,Bath set °C,
Chiller actual °C,Chiller set °C,Rotation rpm,Vapor °C,Hold,AutoDest delta °C,
Foam present,Foam control
1, 960.4, 100.0,*,*, 15.9, 10.0,00, 0.0,0,0,0,0
2, 960.4, 100.0,*,*, 15.9, 10.0,17, 0.0,0,0,0,0
3, 960.4, 100.0,*,*, 15.9, 10.0,22, 0.0,0,0,0,0
4, 953.8, 100.0,*,*, 15.9, 10.0,23, 0.0,0,0,0,0
5, 920.5, 100.0,*,*, 15.9, 10.0,24, 0.0,0,0,0,0
6, 861.5, 100.0,*,*, 15.9, 10.0,24, 0.0,0,0,0,0
7, 789.7, 100.0,*,*, 15.9, 10.0,24, 0.0,0,0,0,0
8, 711.2, 100.0,*,*, 15.9, 10.0,23, 0.0,0,0,0,0
9, 635.9, 100.0,*,*, 15.9, 10.0,19, 0.0,0,0,0,0

```

Fig. 56: Example of a TXT file

**NOTE**

The process data may only be recorded on the genuine BUCHI SD card.



6.4.1 Inserting an SD card

Fig. 57: Inserting SD card

1 Slot

2 BUCHI SD card

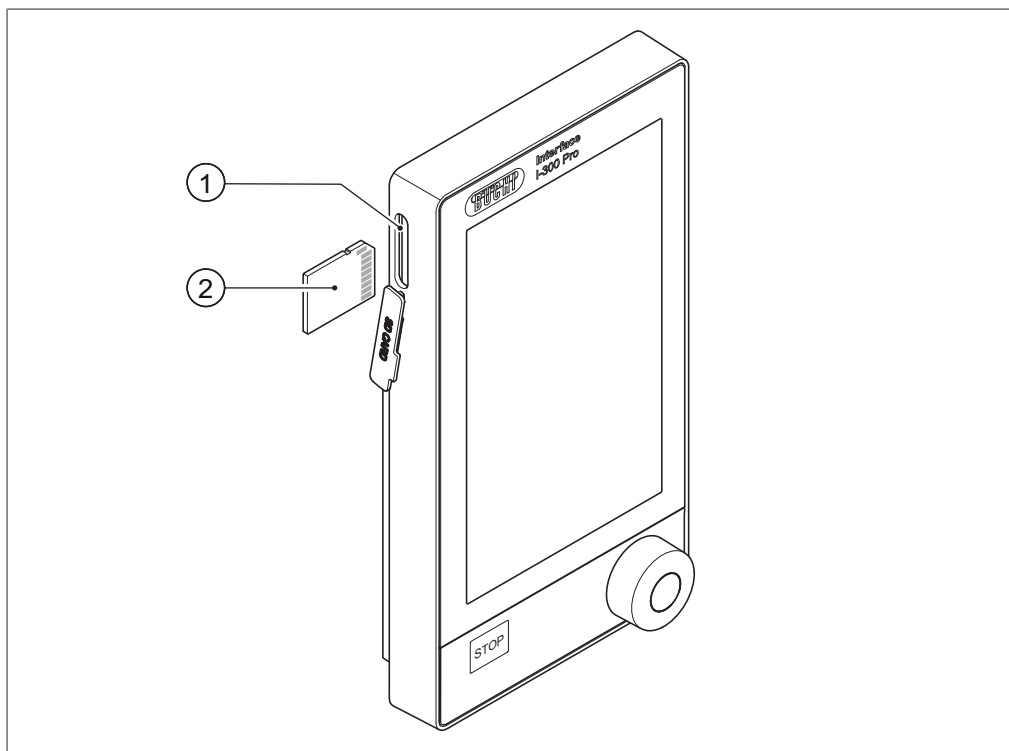

- ▶ The BUCHI SD card is inserted in the slot in the interface unit as shown. When doing so, make sure that the bevelled corner of the SD card is at the top right.
- The display shows the symbol  for SD card inserted on the status bar.

6.4.2 Activating recording

Navigation path

→ Configuration → Settings → Record data

Precondition:

- An SD card has been inserted and the status bar on the display shows the symbol  for SD card inserted.
- ▶ Navigate to the "Settings" screen and select the menu item "Record data", see Chapter 6.1 "Navigating the menu", page 47.
- ▶ Select the option "On".
- When a distillation process is started, the SD card inserted symbol changes to the symbol  for recording process data.

6.5 Solvent library

The Interface I-300 Pro has an internal solvent library. Stored in that library are the most common solvents together with an algorithm in each case. Based on the chemical properties of the solvent, the algorithm calculates and dynamically sets the ideal vacuum according to the current readings for heating bath and coolant temperature. That means that the distillation process can be started immediately even if the ideal heating bath and coolant temperatures have not yet been reached.

6.5.1 Using the solvent library

A distillation process can be started directly from the solvent library. Alternatively, the process parameters can be copied from a specific solvent and manually edited before starting the distillation process.

Navigation path

→ Tools → Solvent library

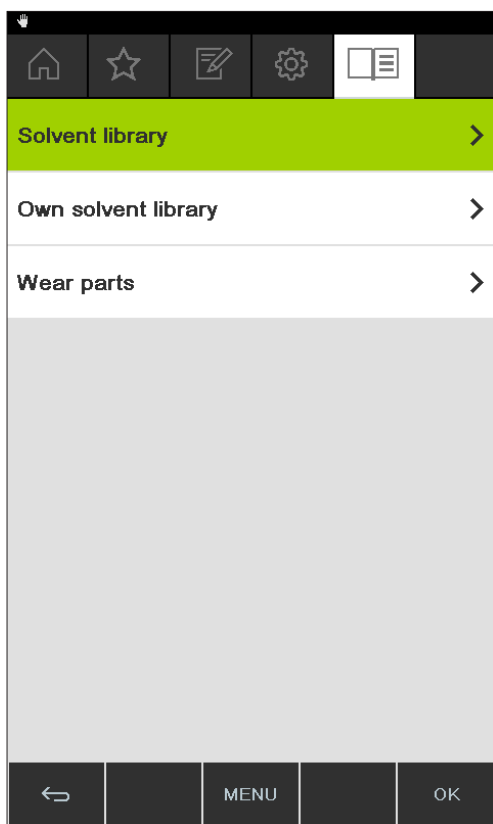

Fig. 58: Selecting "Solvent library" on the "Operating modes" screen

- ▶ Navigate to the "Tools" screen and select the menu item "Solvents", see Navigating the menu.
The display shows the Solvent library submenu.



Fig. 59: Selecting "Acetone" from the Solvent library submenu

- ▶ Select the desired solvent (e.g. acetone).



NOTE

When the heating bath and the recirculating chiller are connected, the actual figures are automatically applied. If equipment of a different make is connected, the set temperatures on the devices concerned have to be entered as specified settings on the interface.



NOTE

Display of calculated values for solvent:

The calculated values for a solvent are based on the chemical properties of the chosen solvent and the settings entered or readings communicated from the heating bath and recirculating chiller.

- ▶ Enter the specified settings for heating bath and coolant temperature if necessary.



Fig. 60: Selecting "Set" temperature for heating bath when using equipment of a different make

- ▶ To start a distillation process directly from the solvent library, press the function button **START**.
The distillation process is started directly.
- ▶ To apply the settings for the selected solvent and return to the interface unit home screen, press **OK**. On the home screen, the settings for the individual process parameters can be edited.

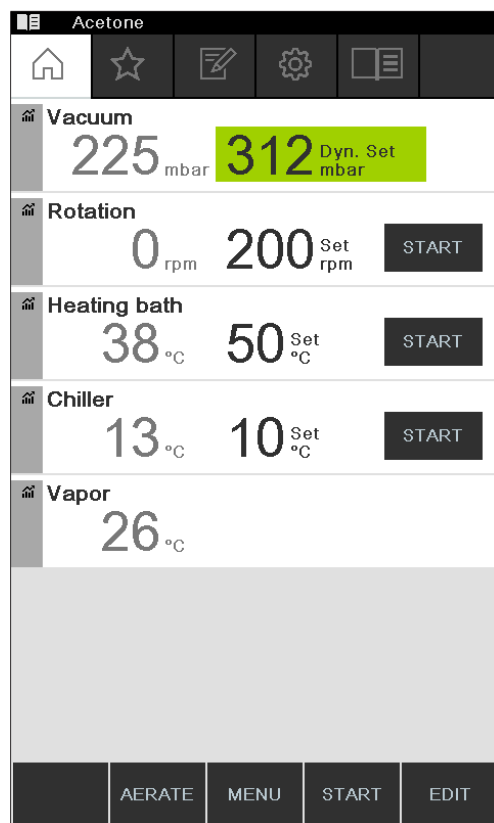

Fig. 61: Editing the specified settings for the selected solvent on the home screen



NOTE

The temperatures for heating bath and coolant should be set so as to be 40 °C apart.

6.5.2 Creating your own solvent library

You can also create your own solvent library in which you can enter details of up to 60 of your own solvents.

Navigation

→ Tools → Own solvent library

- ▶ Navigate to the "Tools" screen and select the menu item "Own solvent library", see Chapter 6.1 "Navigating the menu", page 47.
- ▶ Press NEW to create a new solvent.
The following settings appear:

Solvent	
Boiling point	80 °C
B constant	0.200

Fig. 62: Creating a new solvent

- ▶ Select the menu item "Solvent".
 - ▶ Use the keyboard to enter a name for the solvent and press SAVE to save it.
 - ▶ Enter the boiling point and beta constant of the solvent.
 - ▶ To return to the solvent library, press the function button .
- The newly created solvent now appears in the solvent library.



NOTE

The solvents created can be edited at any time by choosing EDIT or deleted by choosing REMOVE. In addition, the solvents can also be added to your favorites, see Chapter 6.8 "Creating favorites", page 95.

6.6 Activating eco mode

The Interface I-300 Pro offers an "eco mode" option for saving energy if the distillation system remains inactive for a predefined period of time. In eco mode, the distillation system shuts down the activity of the heating bath and recirculating chiller after a defined delay period so that:

- The heating bath does not reheat until the heating bath temperature has dropped to a defined minimum temperature.
- The recirculating chiller does not re-chill until the coolant temperature has risen to a defined maximum temperature.

Navigation path

→ Configuration → Settings → eco mode

- ▶ Navigate to the "Settings" screen and select the menu item "eco mode", see Navigating the menu.
- ▶ On the menu item "eco mode", select the option "On".
- ▶ On the menu item "Activate after", enter the figure for the delay period.
- ▶ On the menu item "Heating bath temperature drop", enter the difference between the current temperature setting and the desired minimum temperature.
- ▶ On the menu item "Coolant temperature rise", enter the difference between the current temperature setting and the desired maximum temperature.

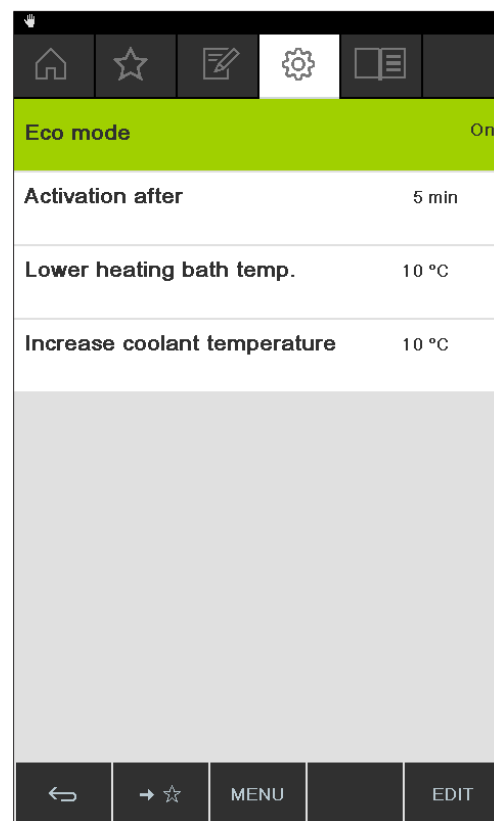

Fig. 63: Selecting "eco mode"

6.7 Setting hysteresis

The hysteresis setting is only relevant if the distillation system is not being operated with a BUCHI Vacuum Pump V-300 but with a different make of pump or with a laboratory vacuum supply, and is controlled by means of a valve.

The hysteresis setting ensures precise pressure regulation by the valve or the valve unit. The hysteresis is the maximum allowed deviation of the vacuum from the specified setting before the system corrects the pressure. The pump is switched off/valve is closed when the vacuum has reached the lowest possible pressure. If the pressure rises and the set hysteresis is exceeded, the pump is switched on again/the valve opened again.

Navigation path

→ Configuration → Settings → Pressure hysteresis

- ▶ Navigate to the "Settings" screen and select the menu item "Pressure hysteresis", see Chapter 6.1 "Navigating the menu", page 47.

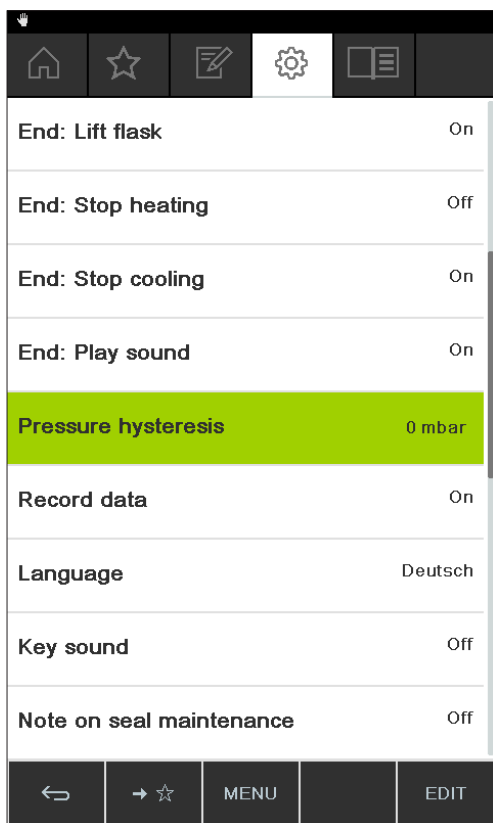

Fig. 64: Setting pressure hysteresis

- ▶ Enter the desired figure for the maximum vacuum deviation from the specified setting.

6.8 Creating favorites

The Interface I-300 Pro offers the facility for saving individual functions and settings as favorites (bookmarks).

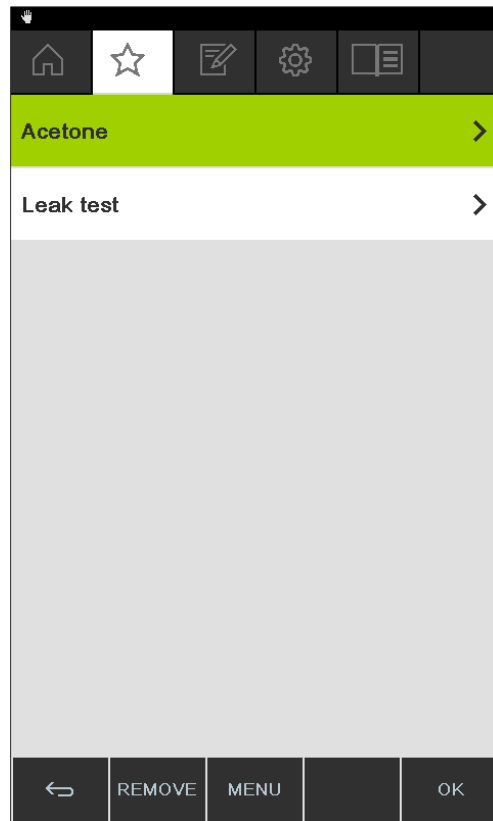

Fig. 65: Submenu "Favorites"

Clicking on any of the saved favorites takes you directly to the screen concerned.

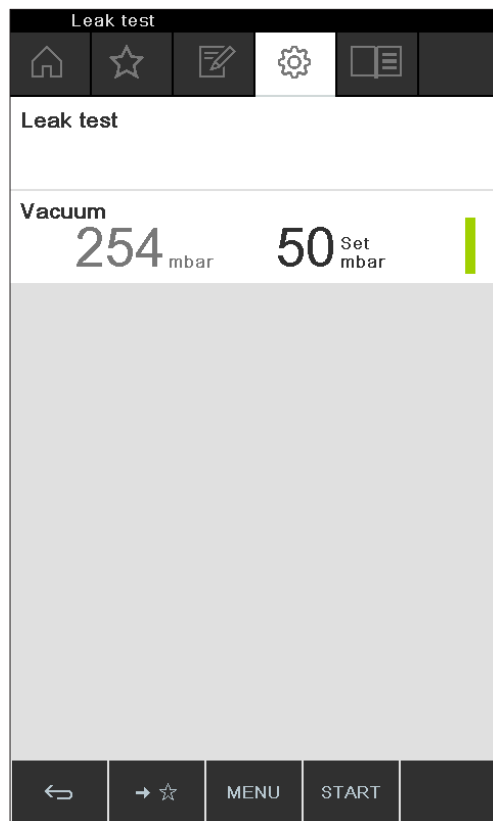



Fig. 66: Example of frequently used screen showing function button "Add to favorites" in bottom menu bar

- ▶ Navigate to a frequently used screen on the interface unit.
 - ▶ To add that screen to your favorites, press the function button below the symbol .
- The screen will then be listed on the submenu "Favorites" the next time it is opened.

7 Mobile connection

7.1 Setting up BUCHI Connect Solution

The BUCHI Connect Solution is an IT solution for mobile monitoring of distillation processes.

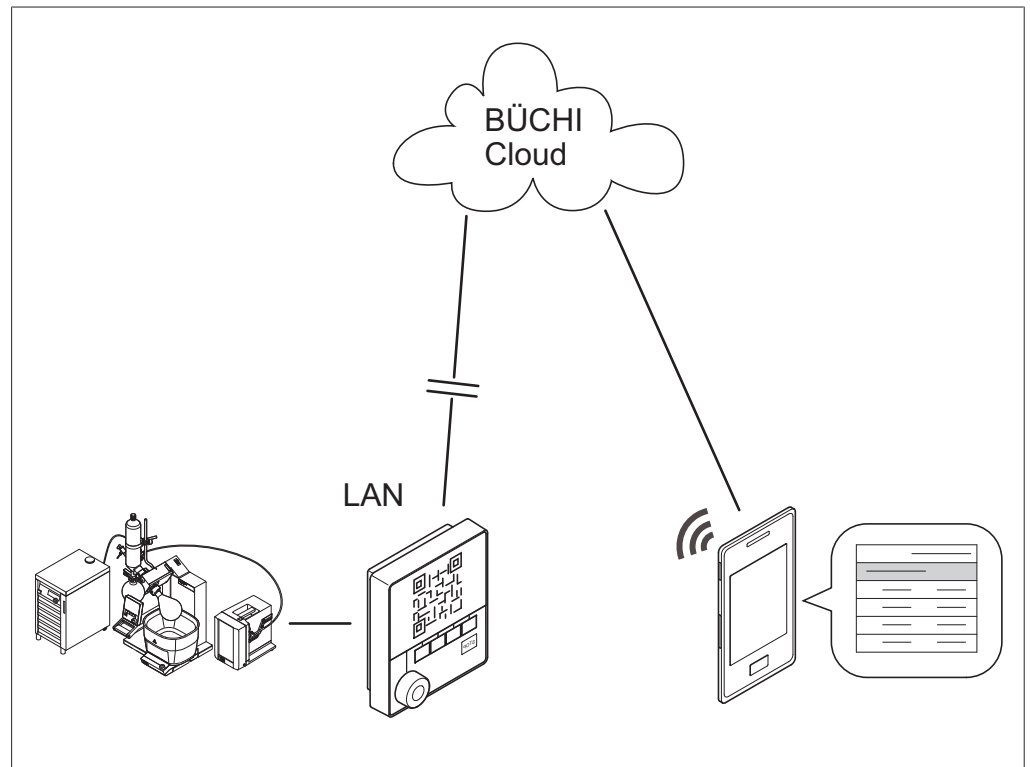

Fig. 67: BUCHI Connect scenario using distillation system, smartphone, cloud and server

The BUCHI Connect Solution allows distillation processes to be tracked and analyzed from a smartphone or tablet while in progress. Push notifications provide information on the status of the apparatus. In that way, the data can be viewed remotely.

The BUCHI Rotavapor mobile app shows the current specified settings and actual readings – as they would be displayed on the interface unit. Depending on which interface unit (I-300 or I-300 Pro) is connected to the company network (LAN), the BUCHI Rotavapor app shows either the alphanumeric data only (I-300) or the data and progression graph (I-300 Pro) for a distillation process.

Setting up the BUCHI Connect Solution requires the following steps:

- ▶ **Connecting up BUCHI laboratory equipment into a complete distillation system.**
See also Chapter 5.2.2 "Overview: setting up communication connections", page 39.
- ▶ **Connecting interface unit with local area network (LAN).**
See Chapter 7.4 "Connecting interface unit to the LAN", page 99.
- ▶ **Assigning dynamic IP addresses (DHCP).**
See Chapter 7.7 "Assigning IP addresses", page 102.
- ▶ **Enabling access to the BUCHI Cloud.**
See Chapter 7.6 "Enabling interface unit for access to BUCHI Cloud", page 101.
- ▶ **Enabling ports on the internet gateway.**
See Chapter 7.3 "Requirements for local network settings", page 98.

- ▶ **Installing the BUCHI Rotavapor app.**
See Chapter 7.8 "Downloading and installing the BUCHI Rotavapor app", page 103.
 - ▶ **Viewing the QR code.**
See Chapter 7.9 "Viewing the QR code", page 104.
 - ▶ **Starting the BUCHI Rotavapor app and adding a new system.**
See Chapter 7.11 "Connecting to the distillation system with the BUCHI Rotavapor app", page 106.
 - ▶ **Scanning the QR code with your smartphone.**
See Chapter 7.12 "Scanning the QR code with your smartphone", page 107.
 - ▶ **Activating push notifications.**
See Chapter 7.13 "Activating push notifications", page 108.
 - ▶ **Testing the BUCHI Connect Solution.**
Starting the distillation process, starting the Rotavapor app and selecting the Rotavapor system.
See Chapter 7.14 "Remotely retrieving process data", page 109.
- The smartphone or tablet screen shows a mobile version of the interface unit home screen.

7.2 Components of the BUCHI Connect Solution

The BUCHI Connect Solution is made up of the following components:

Category	Components	Actions
BUCHI distillation system	Rotavapor R-300 and heating bath	Setting up communication and tubing connections
	Vacuum Pump V-300	
	Recirculating Chiller F-3xx	
	Interface I-300	
	VacuBox	
Network	Public BUCHI Cloud	Enabling access
	Private Cloud Solution server (optional)	Installing software (optional)
	Internal WiFi	Setting up and enabling as necessary
	Mobile network	Ensuring access
Mobile devices	Smartphone	Install the BUCHI Rotavapor app. Registering systems. Subscribing to push notifications.
	Tablet	
Software	BUCHI Rotavapor app	Installing on mobile device
	Server software (optional)	Installing private cloud on local server if required

7.3 Requirements for local network settings

- ▶ The following port has to be enabled in the firewall on the internet gateway:
 - Port 443 (HTTPS) open for TCP

- ▶ In order to use the BUCHI Cloud a DNS server must be configured on the interface unit.

**NOTE**

If there is no DNS server available, the BUCHI Cloud connection must be configured by entering the IP address.

**NOTE**

If there is no DHCP server available, the IP address, gateway subnet mask and DNS server can be configured manually on the interface unit.

7.4 Connecting interface unit to the LAN

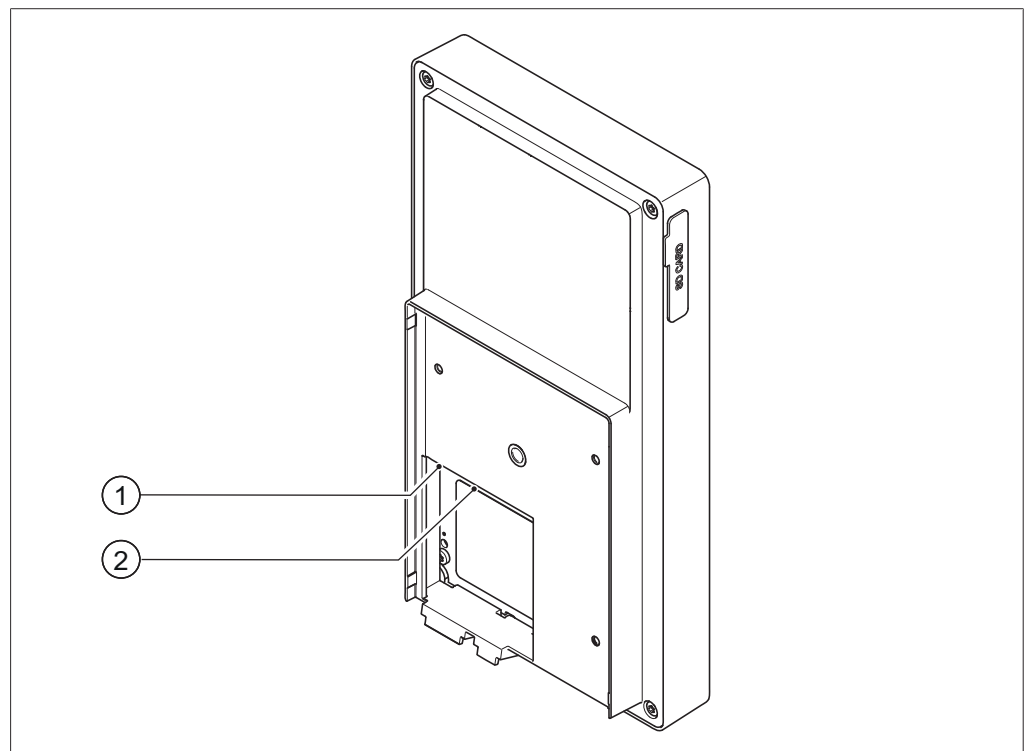

Fig. 68: Rear view of interface unit showing connections

1 LAN port

2 Standard BUCHI communication port (COM)

- ▶ Plug the network cable into the LAN port (1) on the rear of the Interface I-300.

**NOTE**

The LAN cable must not be unplugged while the device is connected to the BUCHI Connect Solution.

7.5 Handling data

The following communication details relate to Version 1.0 of the interface. Information is subject to amendment in respect of extent and content.

**NOTE**

External control of the equipment via the BUCHI Cloud is not implemented.

Data transmission via the LAN interface to the server

Category	Frequency
System data: <ul style="list-style-type: none"> • Serial number of interface unit • System name of interface unit • Interface unit model (I-300 or I-300 Pro) • Firmware version of interface unit • MAC address of interface unit 	Every time connection is established
Status data: <ul style="list-style-type: none"> • Process status (e.g. "Ready", "Running") 	Whenever process changes
Event data: (Messages that appear as pop-ups on the display, e.g. "Distillation successfully completed") <ul style="list-style-type: none"> • Event message ID • Event message level (information, warning or error) 	On occurrence Event messages are managed by the server and distributed to the clients from there for push notifications.
Process data: <ul style="list-style-type: none"> • Actual reading and specified setting for pressure • Actual reading and specified setting for heating bath temperature • Actual reading and specified setting for recirculating chiller temperature • Actual reading and specified setting for rotation speed • Actual reading and specified setting for timer • Actual vapor temperature • Results (stop status, foam detection, receiving flask full) • Timestamp 	Regular data transmission When process is running: once per second at most On standby: at least every 60 seconds

All of the above data (except MAC address) is broadcast to the connected clients (e.g. mobile phone) and processed there.

Data transmission from clients to the server

Category	Frequency
Client data: <ul style="list-style-type: none"> • App language selected • Type of operating system • Operating system version • Platform for push notifications • Push tone setting (not used) • Desired push notification type for each configured device (system data, process data, method data) • Client ID (automatically generated) • Model designation of mobile phone 	When connection is established or changed

Data storage period

Category	Storage period
• System data (inc. date and time of last connection)	Permanent
• Client data (inc. date and time of last connection)	At most 1 year after last use
• Status data	At least 24 hrs, max. 48 hrs
• Event data	Data that is older than 24 hrs is deleted after 24 hrs.
• Process data	

Data configuration settings

Destination host	connect.buchi.com
Destination port	443
Protocol	HTTPS (TLS 1.2)
Certificates	RSA 2048 bit, SHA-256
Server location	Ireland (operator: Amazon Web Services)

7.6 Enabling interface unit for access to BUCHI Cloud

Navigation path

→ Configuration → Settings → Network → BUCHI Cloud

- ▶ Navigate to the "Network" screen and select the menu item "BUCHI Cloud", see Chapter 6.1 "Navigating the menu", page 47.
- ▶ Select the option "Yes".

System name	Rotavapor 01
DHCP	Yes
System IP address	0 . 0 . 0 . 0
Subnet mask	0 . 0 . 0 . 0
Gateway	0 . 0 . 0 . 0
DNS Server	255 . 255 . 255 . 255
BUCHI cloud	<input checked="" type="radio"/> Yes
Server IP address	0 . 0 . 0 . 0

Fig. 69: Enabling interface unit for access to BUCHI Cloud

7.7 Assigning IP addresses

Navigation path

→ Configuration → Settings → Network → DHCP

- ▶ Navigate to the "Network" screen and select the menu item "DHCP", see Chapter 6.1 "Navigating the menu", page 47.
- ▶ Select the option "Yes".
- The IP address will now be dynamically assigned.

System name		Rotavapor 01
DHCP		No Yes Service
System IP address		0 . 0 . 0 . 0
Subnet mask		0 . 0 . 0 . 0
Gateway		0 . 0 . 0 . 0
DNS Server		0 . 0 . 0 . 0
BUCHI cloud		Yes
Server IP address		0 . 0 . 0 . 0

ESC MENU SAVE

Fig. 70: Dynamic IP address assignment option (DHCP) on the "Network" screen

7.8 Downloading and installing the BUCHI Rotavapor app

- ▶ Switch on your smartphone or tablet.
- ▶ Install the BUCHI Rotavapor app.
- ▶ Start the BUCHI Rotavapor app.
- ▶ Set up a new Rotavapor system and scan the QR code on the interface unit display. See Chapter 7.9 "Viewing the QR code", page 104.

7.9 Viewing the QR code

The Interface I-300 Pro can generate a QR code for the distillation system concerned. That QR code can be used to identify the system.

Navigation path

→ Configuration → Settings → Mobile connection QR code

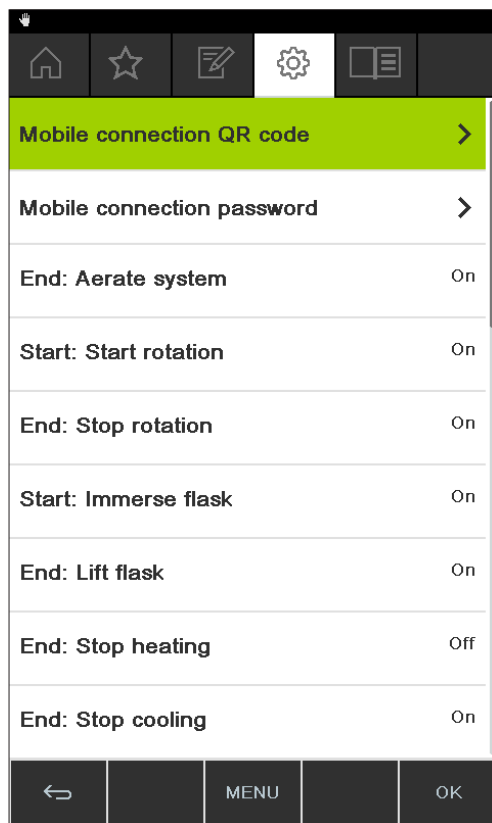

Fig. 71: Selecting "Connection QR code" from the submenu "Settings"

- ▶ Navigate to the "Settings" screen and select the menu item "Connection QR code", see Chapter 6.1 "Navigating the menu", page 47.
- The display shows a QR code. Scanning the QR code using the Rotavapor app allows the mobile device to connect to the distillation system.



- ▶ Scan the QR code with your smartphone, see Chapter 7.12 "Scanning the QR code with your smartphone", page 107.
- ▶ Press OK to return to the menu.

7.10 Generating a password

As an alternative to a QR code, a password can be generated for the distillation system concerned. That password can be used to identify the system.

Navigation path

→ Configuration → Settings → Mobile connection password → Password

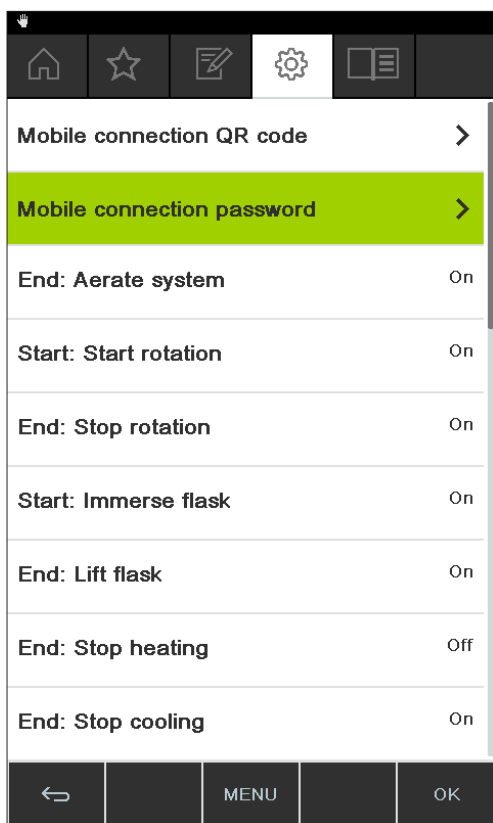

Fig. 72: Selecting item on the "Settings" screen

- ▶ Navigate to the "Connection password" screen and select the menu item "Password", see Chapter 6.1 "Navigating the menu", page 47.
- The display shows the password for connecting to the current distillation system.

7.11 Connecting to the distillation system with the BUCHI Rotavapor app

- ▶ Start the BUCHI Rotavapor app. The app automatically connects to the BUCHI Cloud.
- ▶ Generate and view the QR code on the interface unit of the distillation system concerned. See Chapter 7.9 "Viewing the QR code", page 104.
- ▶ Set up a new Rotavapor system and scan the QR code on the interface unit display with your smartphone.



NOTE

Alternatively, the distillation system can be identified by means of a password. See Chapter 7.10 "Generating a password", page 105.

7.12 Scanning the QR code with your smartphone

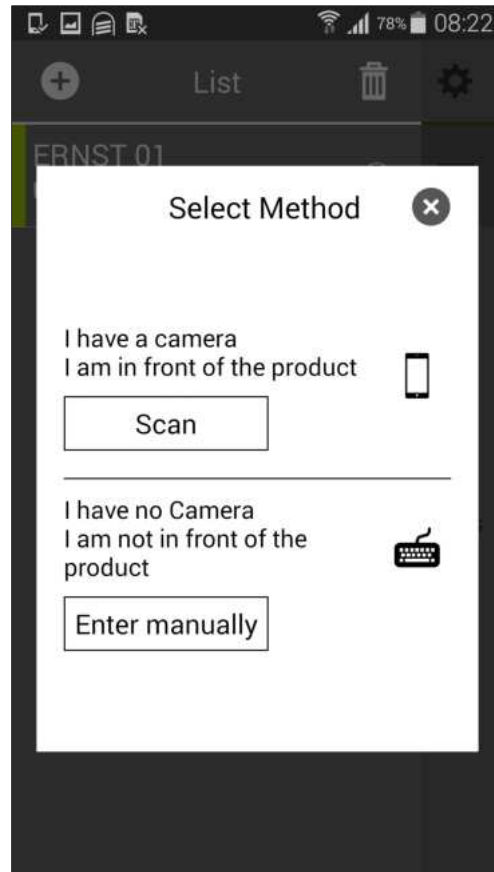

Fig. 73: List of distillation systems in BUCHI Rotavapor app

Precondition:

- ☑ The interface unit shows the QR code for the distillation system concerned.
- ▶ Start the BUCHI Rotavapor app on your smartphone or tablet.
- ▶ Swipe the screen to scroll to the "List" page.
- ▶ Tap the (+) sign in the top left corner.
- ▶ Tap the option "Acquire new system".
- ▶ Select the option "QR code". If you have chosen to identify the system by means of a password, select the option "Password".
- ▶ Using the smartphone's/tablet's inbuilt camera, scan the QR code on the interface unit display. Alternatively enter the password shown.



NOTE

The name of the distillation system as displayed is acquired from the interface unit.

7.13 Activating push notifications

The BUCHI Rotavapor app offers a series of optional push notifications that are automatically sent to the smartphone or tablet while a distillation process is running in order to keep the user up to date with the current status of distillation.

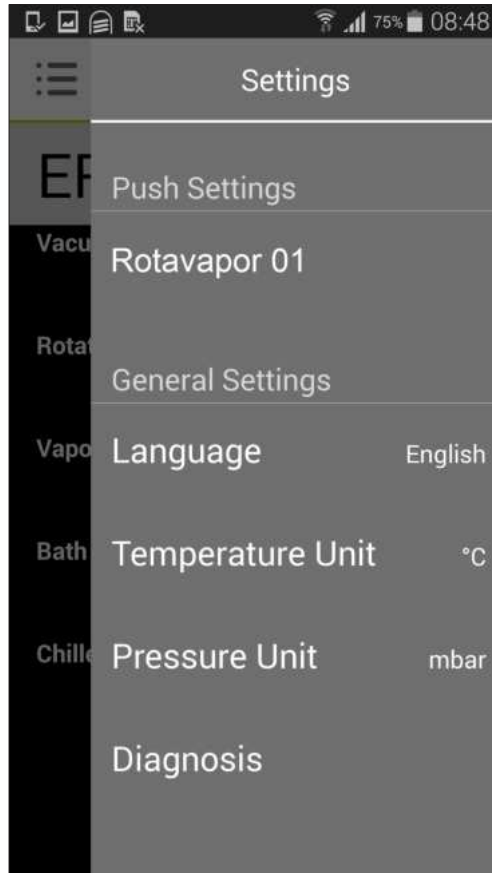

Fig. 74: Setting options in BUCHI Rotavapor app

- ▶ Start the BUCHI Rotavapor app.
- ▶ Swipe the screen to scroll to the "Settings" page.
- ▶ Tap the "Settings" symbol at the top left of the screen.
A new page appears offering a choice of the available push notifications.
- ▶ Tap the desired push notifications to activate them.
- ▶ Save the settings.
- The screen shows the "Settings" page again.

7.14 Remotely retrieving process data

In the BUCHI Rotavapor app you can retrieve the general data for the distillation process currently running.

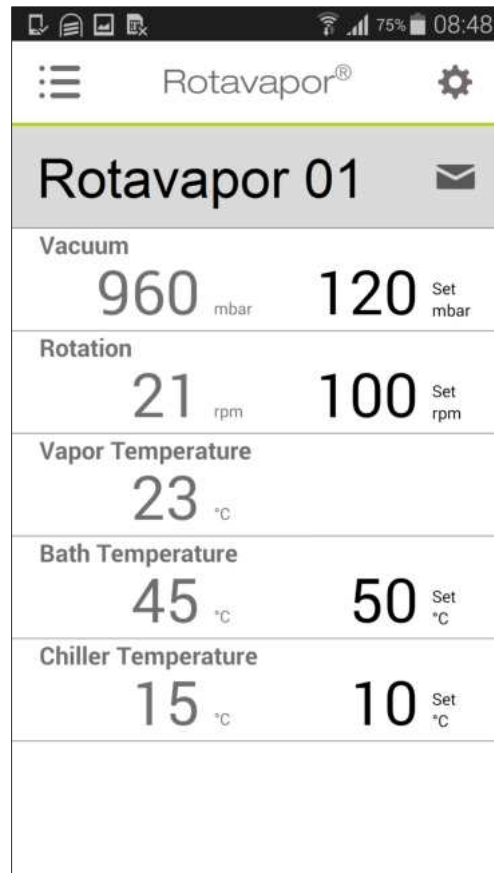

Fig. 75: Start screen of BUCHI Rotavapor app

Precondition:

- BUCHI Rotavapor app is connected to the distillation system.
- ▶ Start the BUCHI Rotavapor app and select the required distillation system. The BUCHI Rotavapor app home screen is displayed showing a summary of the available process parameters.
- ▶ Start the distillation process.
- The screen shows the current specified settings and actual readings for the current process in inverse type.

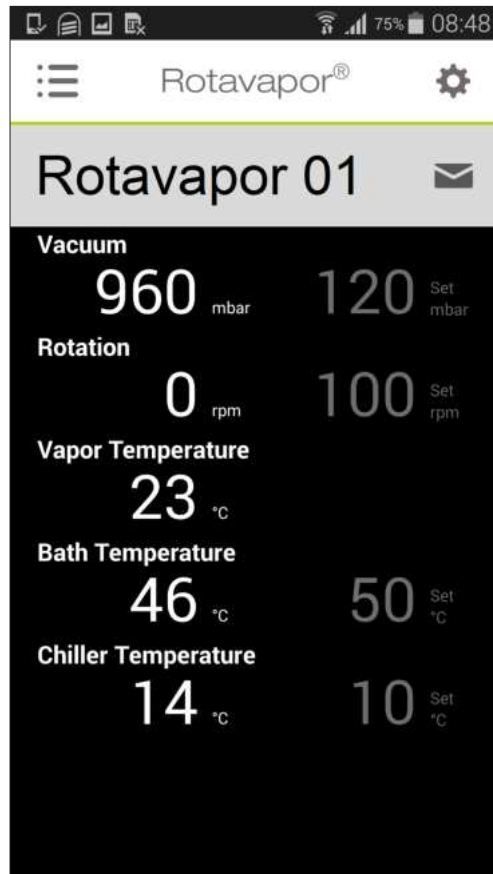

Fig. 76: BUCHI Rotavapor app display while a process is running



NOTE

If the distillation system is equipped with an Interface I-300 Pro then, in addition to the parameter data, a progression graph can be displayed for the following parameters:

- Actual pressure
- Actual bath temperature
- Actual coolant temperature
- Actual rotation speed
- Actual vapor temperature

7.15 Optional function: setting up a local server

As an alternative to the public BUCHI cloud, there is also the possibility of installing the server software within the local network. In that case, the local network operator must define the server IP address. Those details are entered on the interface unit for establishing the connection.

Navigation path

→ Configuration → Settings → Network → Server IP address

Precondition:

The public BUCHI Cloud is not used.

- ▶ Navigate to the "Network" screen and select the menu item "Server IP address".
- ▶ Enter the IP address.

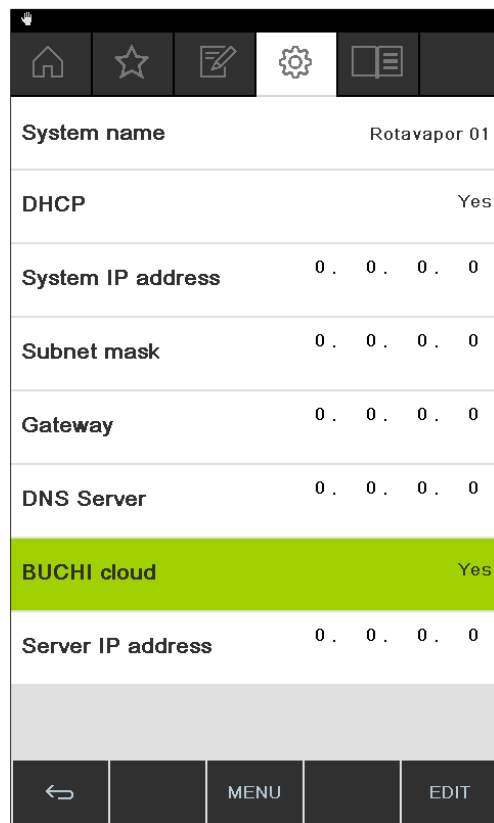

Fig. 77: Selecting item on the "Network" screen



NOTE

For further details, please contact BUCHI Customer Service.

8 Cleaning and servicing



NOTE

Users may only carry out the servicing and cleaning operations described in this section.

Any servicing and repair work which involves opening up the casing may only be carried out by BUCHI service technicians.

- ▶ Use only genuine BUCHI consumables and spare parts in order to ensure correct operation of the device and preserve the warranty.

8.1 Cleaning the casing/display

- ▶ Use a damp cloth to clean the device.
- ▶ To clean the casing, only use ethanol or soapy water.

8.2 Performing a leak test

Navigation path

→ Configuration → Servicing → Leak test

The leak test provides the facility for checking the system for possible leaks.

Precondition:

- All openings in the vacuum system are sealed.
- ▶ Navigate to the "Servicing" screen and select the menu item "Leak test", see Navigating the menu.

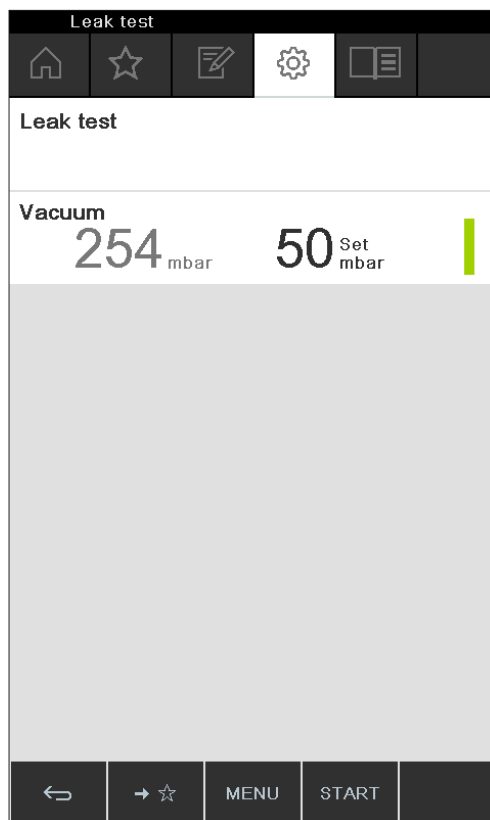

Fig. 78: Leak test screen

- ▶ Press the function button START to start the leak test.
The system is evacuated to 50 mbar within 2 minutes.
- After a stabilization period of 30 seconds, the leakage rate is shown.

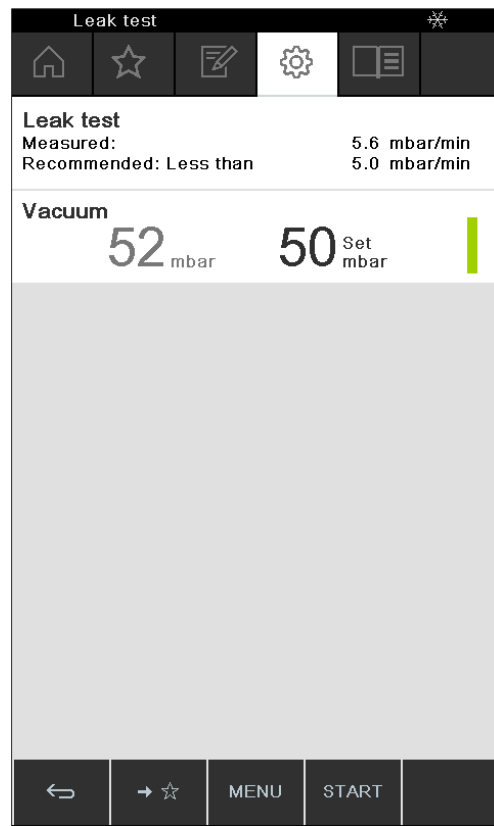

Fig. 79: Display of leakage rate



NOTE

Typically, an airtight system should have a leakage rate of less than 5 mbar/min.

8.3 Fitting GL14 cap nut with tube seal

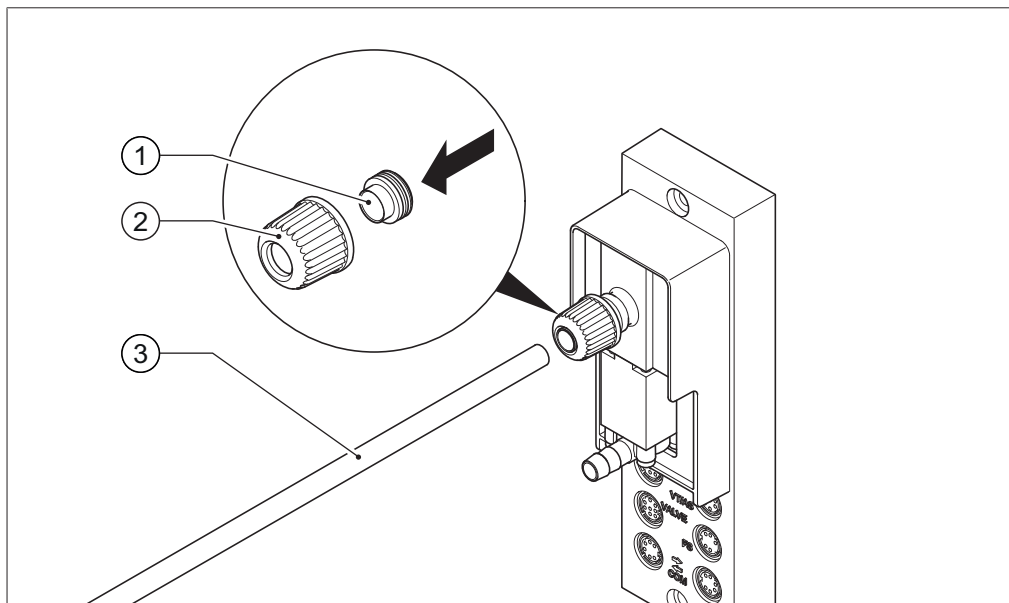

Fig. 80: Fitting GL14 cap nut with tube seal (example shows VacuBox)

1 Tube seal

3 Tubing

2 GL14 cap nut

- ▶ Insert the tube seal (1) in the GL14 cap nut (2) ensuring it is straight.
NOTICE! Risk of damaging tube seal. Make sure that the tube seal does not twist or jam in the GL14 cap nut.
- ▶ Loosely screw the GL14 cap nut together with tube seal onto the device concerned (example shows VacuBox) or the Woulff bottle.
- ▶ Carefully insert the end of the tube (3) into the GL14 cap nut and tube seal.
- ▶ Tighten the GL14 cap nut and tube seal.

8.4 Checking seals

Seals are wearing parts. They have to be regularly inspected, cleaned and, if necessary, replaced. The life of a seal depends on how much it is used and how well it is looked after.

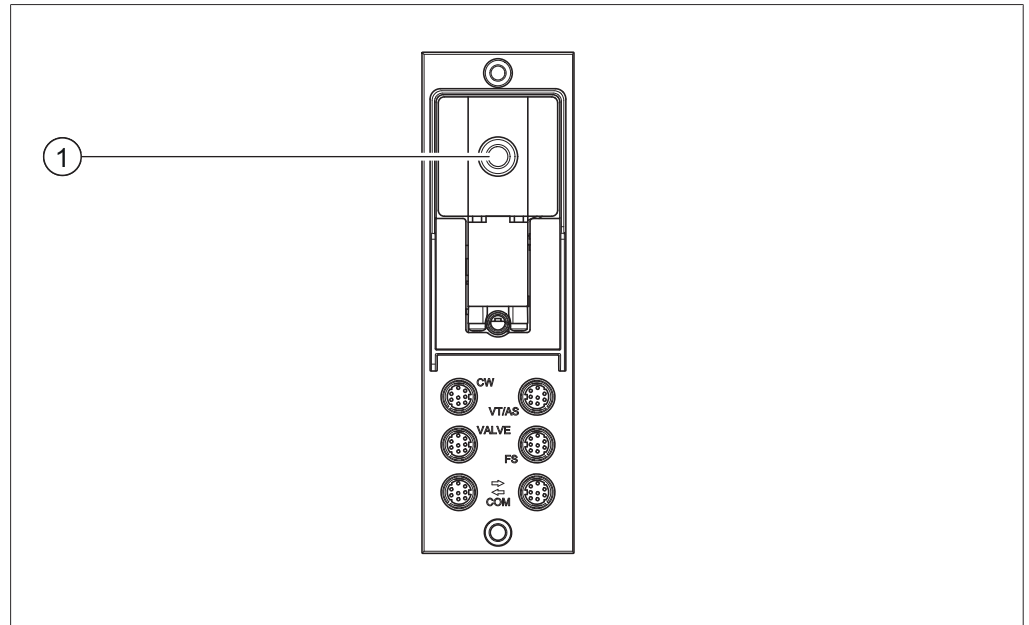

- ▶ Unscrew the GL14 cap nut from the vacuum connection (1) and remove the tube seal.
- ▶ Check the tube seal for signs of damage and cracks.
- ▶ Rinse intact tube seals in water or ethanol and dry with a soft cloth.
- ▶ Replace damaged tube seals.

8.5 Calibrating AutoDest sensor

The AutoDest sensor measures the temperature of the coolant at the inlet and outlet of the cooling condenser. So that relatively small differences in those temperatures can be detected, the difference between the sensors must not be more than 0.3 °C.

Navigation path

→ Configuration → Servicing → Calibrate AutoDest sensor

- ▶ Place the AutoDest sensor in a homogeneous water bath.
- ▶ Navigate to the "Service" screen and select the menu item "Calibrate AutoDest sensor", see Navigating the menu.

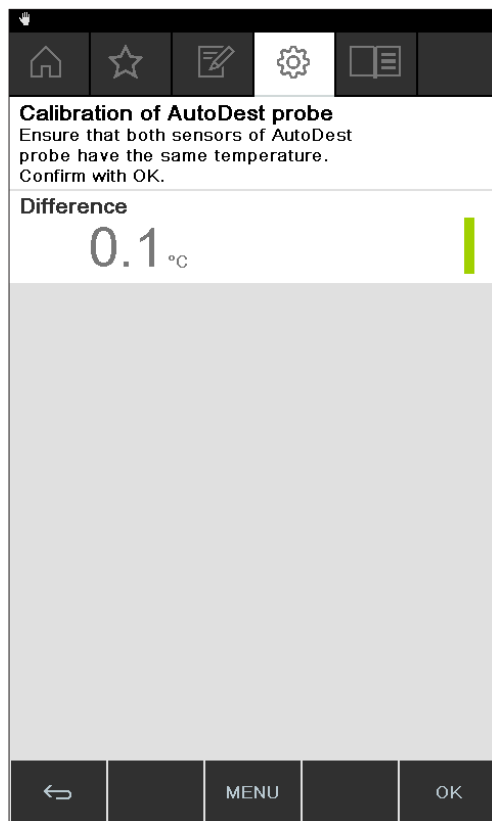

Fig. 81: Menu item "Calibrate AutoDest sensor"

- ▶ Wait until the difference indicated has stabilized.
The two condenser sensors are now at the same temperature.
- ▶ Press the navigation control to choose OK and confirm the calibration offset.

8.6 Calibrating the pressure sensor

The pressure sensor is calibrated at the factory by BUCHI prior to delivery. However, it can be recalibrated with the aid of an external reference pressure gauge at any time.

Navigation path

→ Configuration → Servicing

- ▶ Navigate to the "Configuration" screen and select the menu item "Servicing", see Chapter 6.1 "Navigating the menu", page 47.

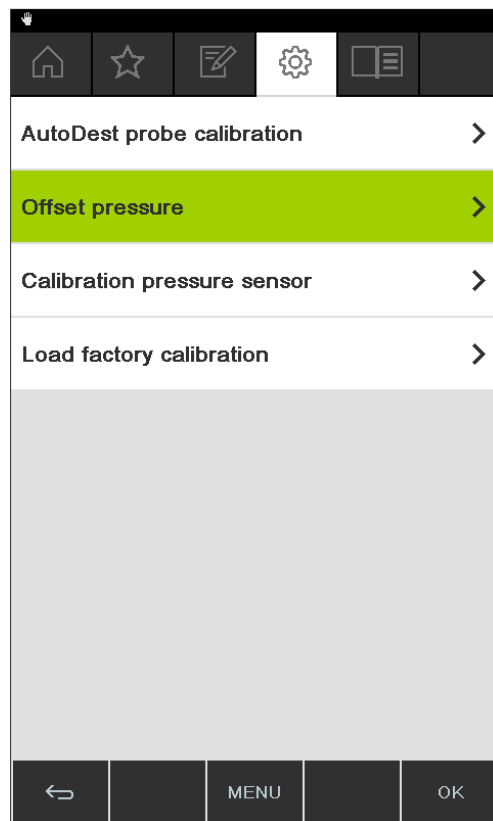

Fig. 82: Selecting item on the "Service" screen

8.6.1 Offset calibration

An offset has to be specified if the pressure indicated on the interface unit differs from the pressure indicated by an external reference pressure gauge. The difference between the two figures is referred to as the offset. The offset applies to the entire pressure range.

Navigation path

→ Configuration → Servicing → Pressure offset

- ▶ Connect the reference pressure gauge to the same vacuum system that the pump and interface unit are connected to.
- ▶ Navigate to the "Service" screen and select the menu item "Pressure offset", see Chapter 6.1 "Navigating the menu", page 47.

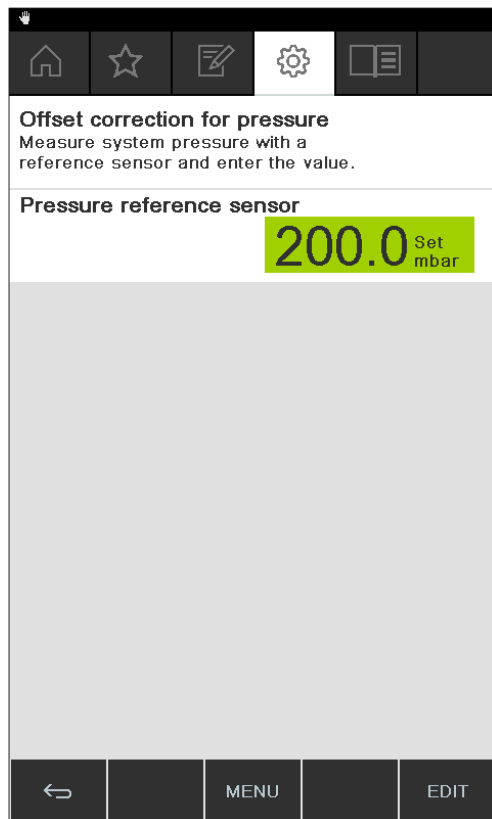

Fig. 83: Menu item "Pressure offset"

- ▶ Enter the pressure measured by the reference sensor.
- The measured readings will then automatically be adjusted by the specified offset.

8.6.2 Simple calibration

This calibration method is used to adjust the linearity of the pressure sensor at specific predefined pressure levels. During the calibration sequence the pressure sensor is calibrated at room temperature in six stages at normal atmospheric pressure and at 800, 600, 400, 200 and 10 mbar.

During the calibration sequence, the system carries out a plausibility check on the measured readings and indicates a fault if the confirmed readings are implausible.

Navigation path

→ Configuration → Servicing → Pressure calibration

- ▶ Connect the reference pressure gauge to the same vacuum system that the pump and interface unit are connected to.
- ▶ Navigate to the "Service" screen and select the menu item "Pressure calibration", see Chapter 6.1 "Navigating the menu", page 47.

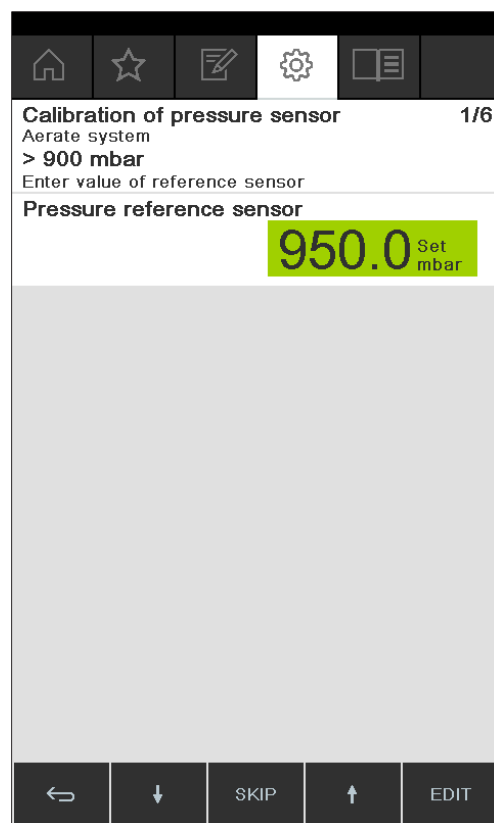



Fig. 84: Menu item "Pressure calibration"

- ▶ In the first stage, enter the pressure indicated by the reference pressure gauge.
- ▶ In the second stage, use the function buttons  and  to increase/decrease the vacuum in the system until the pressure shown on the reference gauge is within ± 10 mbar of the specified setting.
- ▶ Enter the pressure indicated by the reference pressure gauge.
- ▶ Repeat the process for all subsequent stages.
- ▶ To skip a stage, press the function button SKIP.
- ▶ After the last stage, the calibration settings are saved.
- ▶ To return to the menu, press the function button ESC or OK.

8.6.3 Loading factory calibration

This function enables you to reset the calibration to the factory settings as supplied. Any previously saved calibration settings will be deleted.

Navigation path

→ Configuration → Servicing → Back to factory calibration

- ▶ Navigate to the "Service" screen and select the menu item "Back to factory calibration", see Chapter 6.1 "Navigating the menu", page 47.
The device asks you to confirm that the factory calibration should be reloaded.

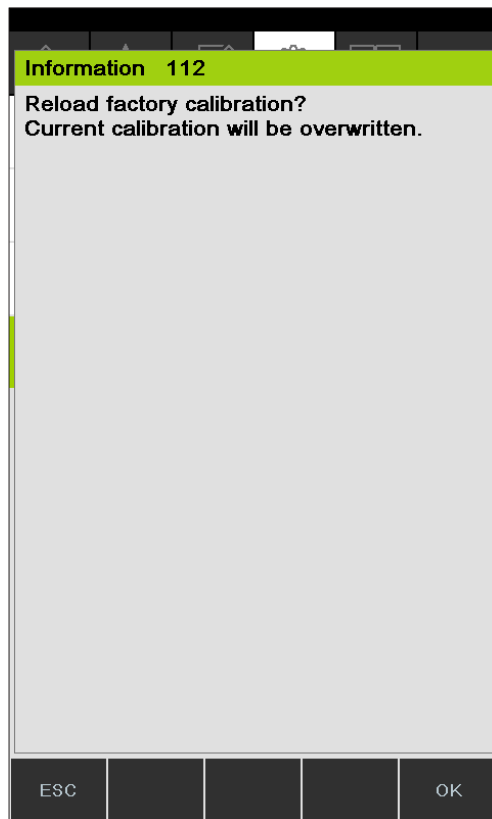

Fig. 85: Menu item "Back to factory calibration"

- ▶ Press the function button OK to confirm or the function button ESC to retain the existing calibration settings.

9 Help with faults

9.1 Faults, possible causes and remedies

Fault	Possible cause	Remedy
Device does not work	Device is not connected to power supply.	▶ Check power supply (see Connections).
Valve or pump frequently switches over	System is leaking.	▶ Check system for leaks (see Rotavapor operating instructions). ▶ If necessary, replace tubing and/or seals.
	Hysteresis setting is too small.	▶ Select a larger hysteresis (for terminal vacuums greater than 700 mbar, set to automatic hysteresis; see Manual mode).
Valve does not switch over	Valve coil is dirty.	▶ Contact BUCHI Customer Service.
	Valve lead not plugged in.	▶ Plug in valve lead.
	Valve is not adjusted.	▶ Contact BUCHI Customer Service.
Vacuum is not achieved	Back-evaporation from the receiving flask.	▶ Empty receiving flask (see Rotavapor operating instructions).
	System is leaking.	▶ Check system for leaks (see Rotavapor operating instructions). ▶ If necessary, replace tubing and/or seals.
	Water pressure of glass filter pump is too low.	▶ Increase water flow (see pump operating instructions).
	Vacuum pump is too weak.	▶ Use suitably dimensioned vacuum pump.

9.2 Error messages



NOTE

The system indicates faults by showing error messages and suggests remedial measures.

9.3 Customer service

Repairs to the device may only be carried out by authorized service technicians. The service technicians have been comprehensively technically trained and are aware of the potential hazards that can arise from the device.

The addresses of the official BUCHI Customer Service offices can be found on the BUCHI website at: www.buchi.com. If you have any questions regarding technical issues or faults, please contact those offices.

Customer Services can offer you:

- supply of spare parts
- repairs
- technical advice

10 Taking out of service and disposal

10.1 Taking out of service

- ▶ Switch off the Interface I-300 Pro and disconnect it from the mains power supply.
- ▶ Remove all tubing and communication cables from the device.

10.2 Disposal

The operator is responsible for proper disposal of the Interface.

- ▶ When disposing of equipment observe the local regulations and statutory requirements regarding waste disposal.

11 Appendix

11.1 Solvent table

Solvent	Formula	Molar mass in g/mol	Evaporation energy in J/g	Boiling point in °C at 1013 mbar	Density in g/cm ³	Vacuum in mbar for 40 °C boiling point
Acetone	CH ₃ H ₆ O	58.1	553	56	0.790	556
<i>n</i> -pentanol	C ₅ H ₁₂ O	88.1	595	37	0.814	11
Benzene	C ₆ H ₆	78.1	548	80	0.877	236
<i>n</i> -butanol	C ₄ H ₁₀ O	74.1	620	118	0.810	25
<i>tert</i> -butanol	C ₄ H ₁₀ O	74.1	590	82	0.789	130
Chlorobenzene	C ₆ H ₅ Cl	112.6	377	132	1.106	36
Chloroform	CHCl ₃	119.4	264	62	1.483	474
Cyclohexane	C ₆ H ₁₂	84.0	389	81	0.779	235
Diethyl ether	C ₄ H ₁₀ O	74.0	389	35	0.714	850
1,2-dichloroethane	C ₂ H ₄ Cl ₂	99.0	335	84	1.235	210
<i>cis</i> -1,2-dichloroethene	C ₂ H ₂ Cl ₂	97.0	322	60	1.284	479
<i>trans</i> -1,2-dichloroethene	C ₂ H ₂ Cl ₂	97.0	314	48	1.257	751
Di-isopropyl ether	C ₆ H ₁₄ O	102.0	318	68	0.724	375
Dioxane	C ₄ H ₈ O ₂	88.1	406	101	1.034	107
DMF (dimethylformamide)	C ₃ H ₇ NO	73.1	–	153	0.949	11
Acetic acid	C ₂ H ₄ O ₂	60.0	695	118	1.049	44
Ethanol	C ₂ H ₆ O	46.0	879	79	0.789	175
Ethylacetate	C ₄ H ₈ O ₂	88.1	394	77	0.900	240
Heptane	C ₇ H ₁₆	100.2	373	98	0.684	120
Hexane	C ₆ H ₁₄	86.2	368	69	0.660	360
Isopropanol	C ₃ H ₈ O	60.1	699	82	0.786	137
Isopentanol	C ₅ H ₁₂ O	88.1	595	129	0.809	14
Methylethylketone	C ₄ H ₈ O	72.1	473	80	0.805	243
Methanol	CH ₄ O	32.0	1227	65	0.791	337
Dichlormethane	CH ₂ Cl ₂	84.9	373	40	1.327	850
Pentane	C ₅ H ₁₂	72.1	381	36	0.626	850
<i>n</i> -propanol	C ₃ H ₈ O	60.1	787	97	0.804	67
Pentachloroethane	C ₂ HCl ₅	202.3	201	162	1.680	13
1,1,2,2-tetrachloroethane	C ₂ H ₂ Cl ₄	167.9	247	146	1.595	20
Tetrachloromethane	CCl ₄	153.8	226	77	1.594	271
1,1,1-trichloroethane	C ₂ H ₃ Cl ₃	133.4	251	74	1.339	300

Solvent	Formula	Molar mass in g/mol	Evaporation energy in J/g	Boiling point in °C at 1013 mbar	Density in g/cm³	Vacuum in mbar for 40 °C boiling point
Tetrachloroethene	C ₂ Cl ₄	165.8	234	121	1.623	53
THF (tetrahydrofuran)	C ₄ H ₈ O	72.1	–	67	0.889	374
Toluene	C ₇ H ₈	92.2	427	111	0.867	77
Trichloroethene	C ₂ HCl ₃	131.3	264	87	1.464	183
Water	H ₂ O	18.0	2261	100	1.000	72
Xylene (mixture)	C ₈ H ₁₀	106.2	389	–	–	25
<i>o</i> -xylene	C ₈ H ₁₀	106.2	–	144	0.880	–
<i>m</i> -xylene	C ₈ H ₁₀	106.2	–	139	0.864	–
<i>p</i> -xylene	C ₈ H ₁₀	106.2	–	138	0.861	–

11.2 Spare parts and accessories

- Use only genuine BUCHI consumables and spare parts in order to ensure correct, safe and reliable operation of the system.



NOTE

Any modifications of spare parts or assemblies are only allowed with the prior written permission of BUCHI.



NOTE

The accessories, wearing parts and spare parts for the Rotavapor R-220 Pro can be found in the operating instructions for the R-220 Pro.

11.2.1 Accessories

Communication cables

Mini-DIN, 0.3 m Connection between Rotavapor R-300 and VacuBox or Vacuum Pump V-300 and VacuBox.	11058705
Mini-DIN, 1.8 m Connection between Rotavapor R-300/VacuBox and Vacuum Pump V-300 or Rotavapor R-300/VacuBox and Recirculating Chiller F-305/ F-308.	11058707
Mini-DIN, 5.0 m Connection between Rotavapor R-300/VacuBox and Vacuum Pump V-300 or Rotavapor R-300/VacuBox and Recirculating Chiller F-305/ F-308.	11058708
Mini-DIN, 15 m Connection between Rotavapor R-220 Pro and separate Interface I-300 Pro.	11064090

Tubing

Natural rubber, dia. 6/16mm, red, per m Use: Vacuum.	017622
Nyflex, PVC-P, dia. 8/14mm, transparent, per m Use: Vacuum, cooling media, feeding (industrial Rotavapor).	004113
Synthetic rubber, dia. 6/13mm, black, per m Use: Vacuum.	11063244

Further accessories

AutoDest sensor. Inc. cap nut, seal GL14 For automatic distillation. Measures temperature of cooling media. Vacuum is adjusted according to cooling capacity of condenser. Meant to be used with the Interface I-300/I-300 Pro and glass assembly V or S.	11059225
Cooling water valve. 24VAC Valve opens coolant feed during distillation. Can be used in combination with a vacuum controller/control unit.	031356
Foam sensor. Inc. holder Prevents sample from foaming into the condenser by aeration of system temporarily. Meant to be used with the Interface I-300/I-300 Pro.	11061167

Holder. For rod, inc. support, fixing clamp To fasten interface on lab-stand.	11059021
Holder. Wall mount, inc. support set To fasten Interface on wall.	11059132
Level sensor. Inc. O-ring, cable, rubber band Prevents an overflow in the receiving flask of condenser/secondary condenser. Placed on receiving flask. Meant to be used with the Interface I-300/I-300 Pro.	11060954
Power adapter. 30V, 30W, frequency 50/60Hz To power vacuum controller/interface.	11060669
SD-card. For Interface I-300 Pro, 1GB For recording of all process parameters. Data can be exported for further analysis.	11061548
Vacuum valve. Magnetic valve, 24V/4W, Mini-DIN, 1.5m Flow valve without flask, meant to be used with a centralized vacuum source or an unregulated vacuum pump. Meant to be used with the Interface I-300/I-300 Pro.	11060706
Vapor temperature sensor. Inc. cap nut, seal GL14 Measures the vapor temperature inside the system. Meant to be used with the Interface I-300/I-300 Pro.	11060707
Valve unit. Inc. Woulff bottle, 125mL, P+G, holder Magnetic valve. Meant to be used with the Interface I-300/I-300 Pro. For operation with non-BUCHI vacuum pumps or house vacuum.	11061887
Water jet pump, B-764. Magnetic valve, FFKM, 24V Used when tap water is used to generate vacuum. Not inclusive: Cooling water valve. Meant to be used with a vacuum Controller V-850/V-855 or interface I-300/I-300 Pro.	031358
Water jet pump, B-767. Magnetic valve (2 off), FFKM, 24V Meant to be used when tap water is used to generate vacuum. Inclusive: Cooling water valve. Meant to be used with a vacuum Controller/interface.	031357
Woulff bottle. 125mL, P+G, inc. holder For trapping particles and droplets and for pressure equalization.	11059905

11.2.2 Wear parts

Hose barbs

Bent, GL14, inc. silicone seal	018916
Set. 2pcs, bent (1), straight (1), GL14, silicone seal Content: Hose barbs, cap nuts, seals.	041939
Set. 4pcs, bent GL14, silicone seal Content: Hose barbs, cap nuts, seals.	037287
Set. 4pcs, straight, GL14, silicone seal Content: Hose barbs, seals.	037642

Further wear parts

Cap nuts, set. 10pcs, screw cap with hole GL14, seal EPDM Content: Hose barbs, cap nuts, seals.	041999
Seal. For cap nut GL14 to FEP, EPDM	038225

Set screwings. Hose barbs and seals GL14, set	11061921
Content: Hose barbs bent 4pcs, hose barbs straight 1pc, cap nuts 4pcs, screw caps 2pcs, seals EPDM 3pcs.	
Tubing. FEP, dia. 6/8mm, transparent	11059909
Connection tubing Woulff bottle.	

11.2.3 Spare parts

Seals

Set. For Woulff bottle/valve unit	045544
Content: O-ring (048406, 5pcs), O-ring (047169, 5pcs).	
Set. For Woulff bottle/valve unit	045545
Content: O-ring (048406, 5pcs), O-ring (047169, 5pcs), spare parts for valve unit (047258), seal (047165).	

Further spare parts

Covering SD-card. For SD-card	11060814
Holder. For valve unit/Woulff bottle	11059908
To fasten valve unit or Woulff bottle.	
Holder. Inc. support, mounting set	11059029
To fasten interface onto Rotavapor.	
Navigation knob. Ø30mm, green/grey, inc. knob case, cover	11059157
For Rotavapor R-300, Heating Bath B-300 Base, Interface I-300/I-300 Pro and Recirculating Chiller F-305/F-308/F-314.	
VacuBox. Inc. support set	11060914
Communication interface between Rotavapor R-300 and Interface I-300/I-300 Pro or Vacuum Pump V-300 and Interface I-300/I-300 Pro.	

11.3 Health and safety approval

To guarantee the health and safety of our staff and to comply with the law and the regulations for handling hazardous materials, for the purposes of health and safety at work and safe disposal of waste, no products may be sent back to BÜCHI Labortechnik AG or repaired unless we have received the declaration below, completed and signed.

Products sent to us will not be accepted for repair until we have received this declaration.

- ▶ Copy the form overleaf and complete it.
- ▶ Make sure that you know the full details of the substances with which the device has been in contact and that all questions have been answered fully and correctly.
- ▶ Send the completed form to us in advance by post or fax. The declaration must reach us before the device.
- ▶ Enclose a copy of the declaration with the device.
- ▶ If the product is contaminated, inform the carrier (in accordance with GGVE/GGVS/RID/ADR).

If the declaration is missing or the procedure described is not followed, the repairs will be delayed. We ask for your understanding and cooperation with regard to these measures.

11.4 Health and safety

Declaration regarding the safety, hazards and safe disposal of waste

To guarantee the health and safety of our staff and to comply with the law and the regulations for handling hazardous materials, regarding health and safety at work, and to comply with safety regulations, health and safety requirements and requirements for safe disposal of waste such as chemical waste, chemical residues or solvents, the form below must be fully completed and signed whenever devices or faulty components are to be sent back to our factory.

Products or components will not be accepted if this declaration has not been provided.

Device	Model:	Part/Device no.:
---------------	--------	------------------

Declaration for non-hazardous materials

We hereby assure that the products returned

- have not been used in the laboratory and are new.
- have not been in contact with toxic, corrosive, biologically active, explosive, radioactive or other hazardous materials.
- are not contaminated. The solvents or residues of the substances pumped have been removed.

Declaration for hazardous materials

In respect of the products returned, we hereby assure that

- all substances (toxic, corrosive, biologically active, explosive, radioactive or otherwise hazardous) that have been pumped by the products or have otherwise been in contact with the products are listed below.
- the products have been cleaned, decontaminated, sterilised inside and outside and all inlets and outlets are sealed.

List of hazardous materials that have been in contact with the products:

Chemical, material	Hazard category

Final declaration

We hereby declare that

- we are fully conversant with the substances that have been in contact with the products and have answered all questions correctly.
- we have taken all measures necessary to prevent potential hazards in respect of the products returned.

Company name or stamp:

Place, date:

Name (block letters), position (block letters):

Signature:

