



# ***LAB Online Exhibition***





## FRUIT TEST™ FT FRUIT RIPENESS TESTER

- FRUITS & VEGETABLES
- HAND-HELD OR TEST STAND
- FOUR MODELS AVAILABLE
- DUAL GRADUATIONS - LB & KG
- ACCURACY VERIFICATION

Accurate Fruit Testing Requires:

- Controlling tip penetration.
- Providing a means to verify gage accuracy.
- Controlling the speed of tip penetration.

### FIRMNESS

The Wagner FT Fruit Ripeness Tester is a compact penetrometer for fruit firmness testing, the universally accepted measure of ripeness. The FT is the growers' indispensable tool for knowing when to pick and ship.

The FT Fruit Tester measures the force required to push a plunger tip of specified size into the fruit pulp. The force reading assists in determining the appropriate picking time or to monitor fruit softening during storage.

Because of the number of fruit and vegetable varieties, geographical locations and other variations, the appropriate firmness for harvesting will vary. Therefore FT users must combine experience and expertise to establish the firmness value that applies to their specific variety and locale.



### IMPROVED DESIGN

The Wagner FT offers improved accuracy by:

- **Controlling Penetration Depth** The new FT 516 and FT 716 penetrometer tips feature a sharp change in diameter making it easier to sight the correct stopping point.
- **Providing Accuracy Verification** The FT Fruit Tester includes an accuracy verification hook for applying test weights to ensure accuracy. One weight equal to the expected force in the fruit test is applied to the FT prior to the daily fruit testing.
- **Improving Repair and Calibration** With the inclusion of the Wagner FDK Series Force Gage, the FT capacities and graduations remain virtually unchanged. More importantly, the FDK Force Gage repair and calibration service is available for the FT Fruit Testers.

When repair or calibration adjustment is required, the FT is returned to Wagner. If rebuildable, the FT is replaced with a rebuilt gage for rapid return at a reasonable cost.

### PROCEDURES

#### Larger Fruits - FT10, FT30 and FT40

1. Select an appropriate plunger tip for the commodity to be tested. See "Applications / Use".
2. Select a random sample of 15 to 25 fruits of uniform size and the same temperature or 3% of the lot to be sampled. For best results, one person should test the lot.
3. Remove a disc of skin on opposite cheeks of the fruit midway between the stem and bottom on sun and shade sides. Then proceed with puncture test.
4. Hold the fruit against a hard surface and force the tip vertically into the pulp at a uniform speed (take 3 seconds). Use the Wagner FTK Test Stand for more controlled fruit testing.
5. The tip should consistently penetrate to the break in tip diameter or to the scribed line on some tips.
7. Record reading to the nearest graduation.

#### Smaller Fruits - FT 02

#### Similar to large fruit testing except:

1. Make a puncture test on only one cheek midway between the stem and the bottom.
2. Removal of the skin is unnecessary.
3. Penetration should be sufficient to obtain peak reading. Repetitive testing will perfect small fruit testing technique.

## ACCURACY VERIFICATION

- Prior to use, the FT accuracy should be verified by testing with weights.
- The FT is supplied with a 2" hook to be used for testing the accuracy of the gage. The hook passes through the hole in the gage housing opposite the plunger and is screwed into a threaded hole located internally. Test weights then may be suspended on the hook.
- Periodical testing of the FT accuracy should be performed with a test weight suspended on the hook. One weight equal to the expected nominal force of the fruit test is applied to the FT prior to daily testing.
- Do not attempt to adjust the FT if found to be inaccurate. The FT is sealed and any attempt to adjust it may damage the gage. Contact Wagner Instruments for instructions.
- The FT is calibrated with the peak hold active, i.e. peak hold button NOT pressed. When verifying calibration with test weights, do NOT hold the button down.

## SPECIFICATIONS

MODEL*	GAGE	CAPACITY	ACCURACY	TIPS
FT 02 (FT 02)	FDK 32	2 lbf x 1/4 ozf 1 kgf x 10 gf	± 2 Grad	FT 18
FT 10 (FT 011)	FDK 160	10 lbf x 2 ozf 5 kgf x 50 gf	± 1 Grad	FT 516
FT 30 (FT 327)	FDK 30	30 lbf x .25 lbf 14 kgf x 100 gf	± 1 Grad	FT 516 / FT 716
FT 40 (FT 444)	FDK 40	40 lbf x .5 lbf 20 kgf x 200 gf	± 1 Grad	FT 14

\* Indicates current and (previous) model.

- The FT is calibrated in the vertical position with only the verification hook attached.
- The FT has no zero and therefore no provision for adjusting the dial to a zero position.

## APPLICATIONS / USE

The various capacities of FT Fruit Testers are used with specific size penetrometer tips for testing ripeness of specific fruit.

MODEL	TIP	APPLICATIONS
FT 02 FT 18	(3mm)	Berries & Small Fruits
FT 10 FT 516	(8mm)	Peaches & Soft Fruits
FT 30 FT 516	(8mm)	Pears & Firm Fruits
FT 30 FT 716	(11mm)	Apples
FT 40 FT 14	(6mm)	Avocados & Hard Fruits

Small Fruits: Cherry, Grape & Berries  
 Soft Fruits: Peach, Apricot, Plum, Melon, Citrus, Persimmon  
 Firm Fruits: Pear, Nectarine, Kiwi  
 Hard Fruits: Avocado

The FT Fruit Tester may be used hand-held or mounted on the compact Wagner FTK 100 test stand for greater accuracy through positive test control.

## MAINTENANCE

- Before daily use, exercise the plunger in and out for 10 seconds to ensure the mechanism functions freely.
- After daily use, clean the penetrometer tips, splash plate and the exposed gage load shaft by thoroughly flushing with water. Carefully hold the gage with the load shaft pointing down under a slowly flowing water faucet for 10 - 15 seconds, dry with a towel and allow to dry further by standing it with shaft pointing down.
- The FT should never be lubricated with oil since this will accumulate dust causing increased friction and decreased accuracy.
- Should the FT mechanism become inoperable even with a thorough cleaning, return the FT to Wagner for evaluation and possible replacement with a rebuilt gage.



Wagner Fruit Test™ Model FT



FT shown mounted on FTK Test Stand

### FT DIMENSIONS

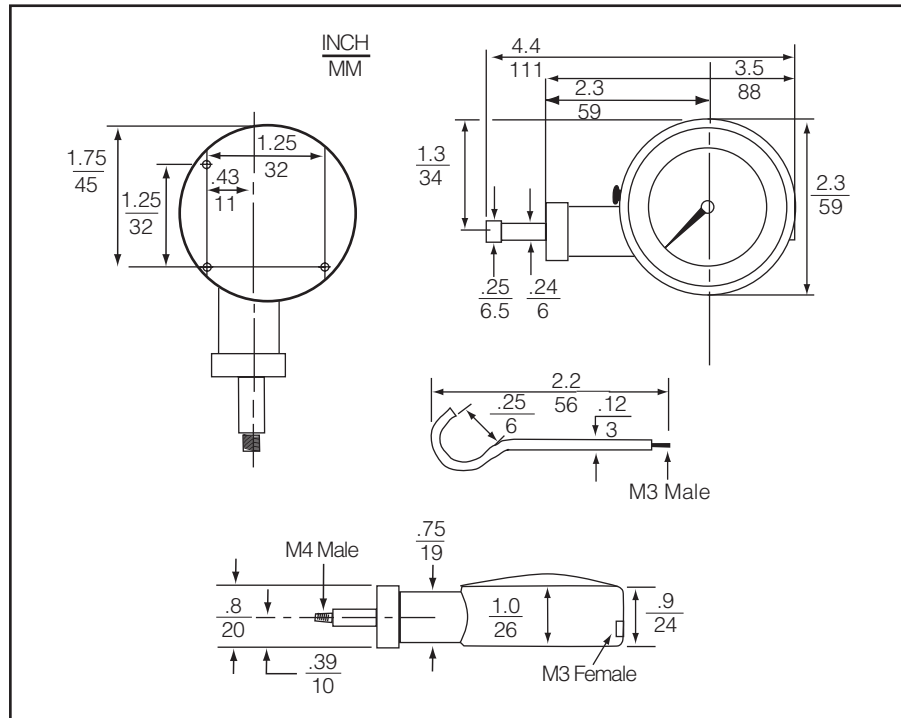

**WAGNER INSTRUMENTS**  
 P.O.B. 1217 GREENWICH CT 06836-1217  
 TEL: (800) 345-4188 or (203) 698-9681  
 FAX: (800) 443-4149 or (203) 698-9696  
 www.wagnerinstruments.com  
 e-mail: sales@wagnerinstruments.com



Wagner Model FT Accessories

#### Warranty and Limitation of Liability

Wagner Instruments expressly warrants to its buyer for one year from the date of purchase that the goods sold shall be free from defects in workmanship and materials under normal conditions. Wagner Instruments will, at its option, replace, repair, or refund in full, the purchase price of the instrument or any part thereof which in our opinion is defective, provided the instrument has not been subjected to tampering, abuse or exposed to highly corrosive conditions. An instrument that has been improperly used cannot be considered under this warranty. We make no warranties, expressed or implied, including, without limitation, any warranties of fitness or merchantability, except as expressly set forth above. We shall not be liable for any anticipated or lost profits, incidental damages, consequential damages, costs, time charges, or other losses in connection with the instrument or replacement parts thereof. If a manufacturing defect is found, we will replace or repair the instrument or any defective part thereof without charge; however, our obligation hereunder does not include the cost of transportation which must be borne by the customer. We assume no responsibility for damage in transit, and any claims for such damage should be presented to the carrier by the purchaser. In addition, we may, at our option, take back the defective instrument and refund, in full settlement, the purchase price thereof.

### WAGNER FT FRUIT TESTER - SPECIFICATIONS

MODEL*	GAGE	CAPACITY	ACCURACY	TIPS
FT 02 (FT 02)	FDK 32	32 ozf x 1/4 ozf	± 2 Grad	FT 18
FT 10 (FT 011)	FDK 160	10 lbf x 2 ozf	± 1 Grad	FT 516
FT 30 (FT 327)	FDK 30	30 lbf x .25 lbf	± 1 Grad	FT 516 / FT 716
FT 40 (FT 444)	FDK 40	40 lbf x .5 lbf	± 1 Grad	FT 14

\* Indicates current and (previous) model.

- The FT is calibrated in the vertical position with only the verification hook attached.
- The FT has no zero and therefore no provision for adjusting the dial to a zero position.



### FRUIT TEST™ FT SERIES FRUIT TESTER

**OPERATION MANUAL  
IMPORTANT INSTRUCTIONS  
READ BEFORE USING GAGE**



**WAGNER INSTRUMENTS**  
P.O.B. 1217 GREENWICH CT 06836-1217  
TEL: (800) 345-4188 or (203) 698-9681  
FAX: (800) 443-4149 or (203) 698-9696  
[www.wagnerinstruments.com](http://www.wagnerinstruments.com)