

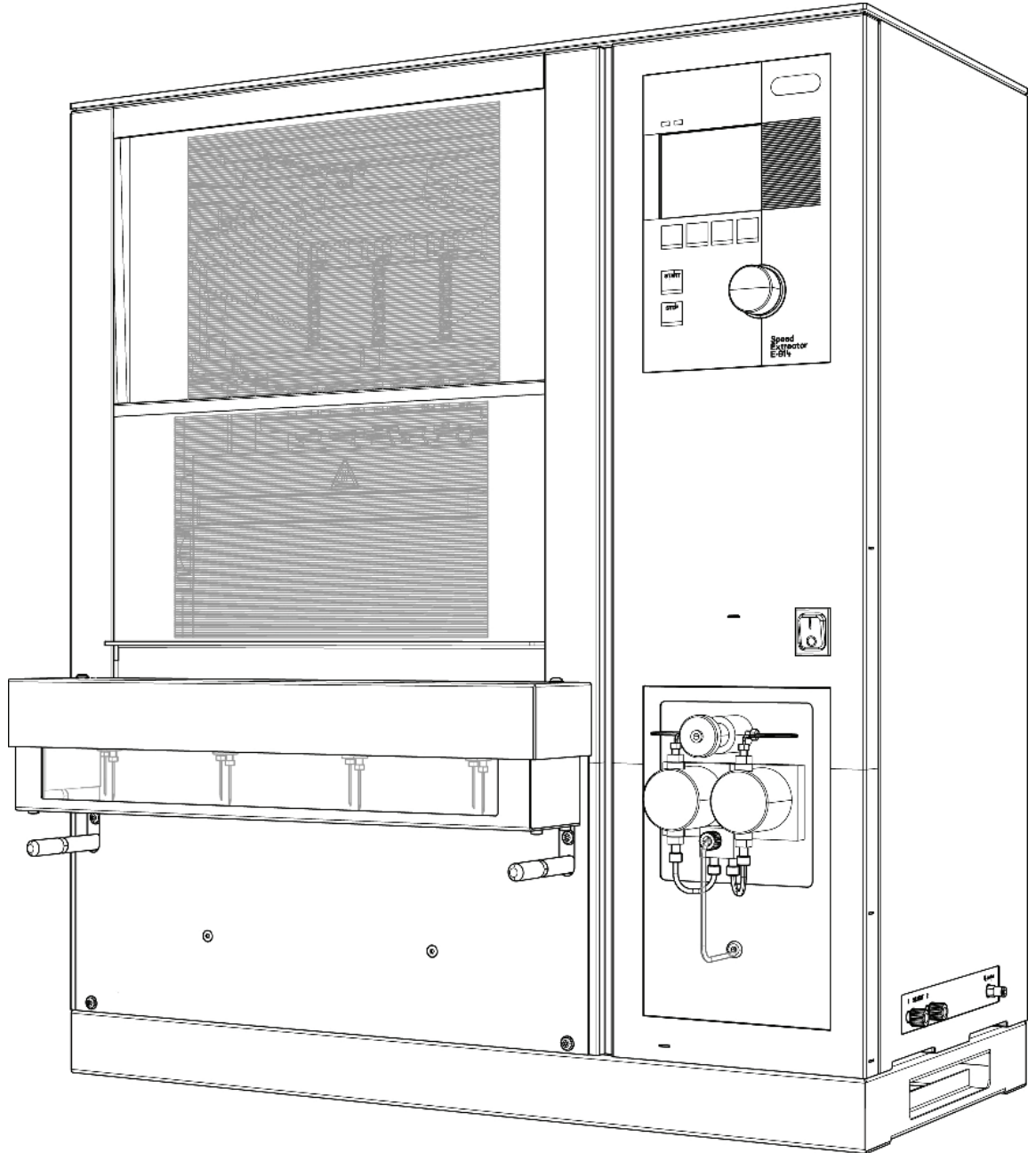

SpeedExtractor E-916 / E-916XL / E-914

Operation Manual



093218G en

Imprint

Product Identification:
Operation Manual (Original), SpeedExtractor E-916 / E-916XL / E-914

093218G en

Publication date: 07.2019

BÜCHI Labortechnik AG
Meierseggestrasse 40
Postfach
CH-9230 Flawil 1

E-Mail: quality@buchi.com

BUCHI reserves the right to make changes to the manual as deemed necessary in the light of experience; especially in respect to structure, illustrations and technical detail.

This manual is copyright. Information from it may not be reproduced, distributed, or used for competitive purposes, nor made available to third parties. The manufacture of any component with the aid of this manual without prior written agreement is also prohibited.



LAB Online Exhibition



Table of contents

1	About this manual.....	5
1.1	Reference documents	5
1.2	Trademarks.....	5
1.3	Abbreviations	6
2	Safety	7
2.1	User qualification	7
2.2	Proper use.....	7
2.3	Improper use	7
2.4	Safety warnings and safety signs used in this manual	8
2.5	Product safety	10
2.5.1	General hazards	10
2.5.2	Warning labels on housing and assemblies	11
2.5.3	Personal protective equipment	11
2.5.4	Built-in safety elements and measures	12
2.6	General safety rules.....	13
3	Technical data	15
3.1	Scope of delivery.....	15
3.2	Instrument configurations.....	15
3.3	Materials used	18
3.4	Technical data overview	18
4	Description of function	21
4.1	Functional principle	21
4.2	Overview of the instrument.....	21
4.3	Overview of the extraction process	23
4.4	Schematic representation of the process	24
4.5	Controls and connections.....	25
4.5.1	Instrument controls.....	25
4.5.2	Main displays of the instrument	26
4.5.3	General information on buttons.....	29
4.5.4	Rear connections.....	30
4.5.5	Side connections	30
5	Putting into operation	31
5.1	Installation site.....	31
5.2	Electrical connections	32
5.3	Gas and solvent connections.....	33
5.4	Dehydration	34
5.5	Functional test	34

6	Operation	35
6.1	Method development.....	35
6.2	Preparing the instrument	36
6.2.1	Solvent reservoir.....	36
6.2.2	Modifying the SOLVENT LIST	37
6.2.3	Preheating the instrument	38
6.2.4	Activating/deactivating positions.....	39
6.2.5	Leak test.....	40
6.2.6	Flushing the instrument	43
6.2.7	Activating the EcoMode	44
6.3	Preparing the sample	45
6.3.1	Sample preparation.....	45
6.3.2	Extraction cell selection.....	46
6.3.3	Packing of the cells	46
6.4	Extraction process	49
6.4.1	Placing the cells and bottles/vials into the instrument.....	49
6.4.2	Stages of an extraction cycle	50
6.4.3	Creating new methods.....	51
6.4.4	Summary of operating parameters	54
6.4.5	Example of an extraction method	56
6.4.6	Open an existing method	56
6.4.7	Optimize a process	57
6.4.8	Start, pause, stop and abort extraction.....	58
6.4.9	Post-extraction procedures	58
6.5	Creating a report (optional)	59
7	Maintenance.....	61
7.1	Daily maintenance.....	61
7.2	Periodic maintenance	62
7.2.1	Sealing system.....	62
7.2.2	Replacing the cup seals	62
7.2.3	Tube connections and needles	63
7.2.4	Septum.....	65
7.3	Pump maintenance.....	66
7.3.1	Connections	66
7.3.2	Back washing	67
8	Troubleshooting.....	69
8.1	Malfunctions and their remedy	69
8.1.1	Action in case of a fire.....	69
8.1.2	General malfunctions and their remedy.....	69
8.1.3	Handling and resolving blockages	74
8.1.4	The pump is not aspirating properly	79
8.1.5	Replacement of check valves.....	80
8.1.6	Precipitation in the outlet lines.....	81
8.1.7	Malfunctions of the rotating valves.....	82
8.1.8	Upgrading a 2-port mixer to a 4-port mixer	82

8.2	Description of the service menu	83
8.2.1	Checking the valves	84
8.2.2	Checking the sensors.....	85
8.2.3	Running the pump	85
8.2.4	Inspecting the lines (flow test)	86
8.2.5	Moving the cell and vial lift	88
8.2.6	Changing the fan performance.....	88
8.2.7	Displaying the operating hours	88
8.2.8	Unit information	88
8.3	Customer service.....	89
9	Shutdown, storage, transport and disposal.....	91
9.1	Storage and transport.....	91
9.2	Disposal.....	92
9.3	Health and safety clearance.....	93
10	Spare parts	95
11	Declarations and requirements.....	105
11.1	FCC requirements (for USA and Canada)	105

Read this manual carefully before installing and running your system and note the safety precautions in chapter 2 in particular. Store the manual in the immediate vicinity of the instrument, so that it can be consulted at any time. No technical modifications may be made to the instrument without the prior written agreement of BUCHI. Unauthorized modifications may affect the system safety or result in accidents.

This manual is copyright. Information from it may not be reproduced, distributed, or used for competitive purposes, nor made available to third parties. The manufacture of any component with the aid of this manual without prior written agreement is also prohibited.

The English manual is the original language version and serves as basis for all translations into other languages. If you need another language version of this manual, you can download available versions at www.buchi.com.

1 About this manual

This manual describes the SpeedExtractor E-916 / E-914 and provides all information required for its safe operation and to maintain it in good working order. It is addressed in particular to laboratory personnel and operators.

NOTE

The symbols pertaining to safety are explained in chapter 2.

1.1 Reference documents

For information on complementary BUCHI devices, please refer to the corresponding manuals:

Complementary devices

MultivaporP-6/P-12, Operation Manual

Vacuum Controller, Operation Manual

Vacuum Pump, Operation Manual

Syncore Platform, Operation Manual

Syncore Accessories, Operation Manual

NOTE

- All manuals are available via www.buchi.com
- For download a free online registration is required

1.2 Trademarks

The following product names and any registered and unregistered trademarks mentioned in this manual are used for identification purposes only and remain the exclusive property of their respective owners:

- SpeedExtractor is a registered trademark of BÜCHI Labortechnik AG
- ASE is a registered trademark of Dionex Corporation

1.3 Abbreviations

Process-related

ASE	Accelerated Solvent Extraction
PSE	Pressurized Solvent Extraction

Materials and chemicals

FEP	Combination of tetrafluoroethylene and hexafluoropropylene
FFPM	Perfluoro caoutchouc
PTFE	Polytetrafluoroethylene
POM	Polyoxymethylene (commercialized as Delrin® by DuPont)
PEEK	Polyether ether ketone
THF	Tetrahydrofurane

Miscellaneous

FW	firm ware
qty	quantity
ΔT	Temperature difference
Δp	Pressure difference

2 Safety

This chapter highlights the safety concept of the SpeedExtractor and contains general rules of behavior and warnings about hazards concerning the use of the product.

The safety of users and personnel can only be ensured if these safety instructions and the safety related warnings in the individual chapters are strictly observed and followed, therefore, the manual must always be available to all persons performing the tasks described herein.

2.1 User qualification

The instrument may be used only by laboratory personnel or other persons who on account of instruction or professional experience have an overview of the dangers that can develop when operating the instrument.

Personnel without such instruction or persons who are currently being trained require careful supervision. The present Operation Manual serves as a basis for instruction.

2.2 Proper use

The instrument has been designed and built for laboratory use only. It serves for activities associated with the parallel extraction of multiple samples by means of heating under pressure. The pressure is typically applied by the HPLC pump.

2.3 Improper use

Applications beyond those described above are improper. Furthermore, applications that do not comply with the technical data are also considered improper. The operator bears the sole risk for any damage caused by such improper use.



The following applications are expressly forbidden:

- Use of solvents with a self ignition point between 40 to 220 °C.
- Use of the instrument in rooms that require ex-protected instruments.
- Use as a calibrating instrument for other instruments.
- Preparation of samples that can explode or inflame due to shock, friction, heat, or spark formation.
- Use in high pressure situations, i.e. > 200 bar.
- Use in conjunction with solvents that have a low self ignition point or contain peroxides, such as diethyl ether or THF.
- Use of cells, seals, hoses, and tubes other than the originals from BUCHI.

2.4 Safety warnings and safety signs used in this manual

DANGER, WARNING, CAUTION and NOTICE are standardized signal words for identifying levels of hazard seriousness of risks related to personal injury and property damage. All signal words, which are related to personal injury are accompanied by the general safety sign.

For your safety it is important to read and fully understand the table below with the different signal words and their definitions!

Sign	Signal word	Definition	Risk level
	DANGER	Indicates a hazardous situation which, if not avoided, will result in death or serious injury.	★★★★★
	WARNING	Indicates a hazardous situation which, if not avoided, could result in death or serious injury.	★★★★☆
	CAUTION	Indicates a hazardous situation which, if not avoided, may result in minor or moderate injury.	★★★☆☆
no	NOTICE	Indicates possible property damage, but no practices related to personal injury.	★☆☆☆☆ (property damage only)

Supplementary safety information symbols may be placed in a rectangular panel on the left to the signal word and the supplementary text (see below example).













Space for supplementary safety information symbols.	 SIGNAL WORD
	Supplementary text, describing the kind and level of hazard/risk seriousness. <ul style="list-style-type: none"> List of measures to avoid the herein described, hazard or hazardous situation.

Table of supplementary safety information symbols

The reference list below incorporates all safety information symbols used in this manual and their meaning.

Symbol	Meaning
	General warning
	Electrical hazard
	Harmful to life-forms

Symbol	Meaning
	Fire hazard
	Hot item, hot surface
	Device damage
	Inhalation of substances
	Chemical burns by corrosives
	Wear laboratory coat
	Wear protective goggles
	Wear protective gloves
	Heavy weight, lifting requires more than one person

Additional user information

Paragraphs starting with Note transport helpful information for working with the device/software or its supplementary. Notes are not related to any kind of hazard or damage.

NOTE

Useful tips for the easy operation of the instrument/software.





2.5 Product safety



The SpeedExtractor has been designed and built in accordance with current state-of-the-art technology. Safety warnings in this manual (as described in section 2.4) serve to make the user alert to and avoid hazardous situations emanating from residual dangers by giving appropriate counter measures. However, risks to users, property and the environment can arise when the instrument is damaged, used carelessly or improperly.

2.5.1 General hazards

The following safety messages show hazards of general kind which may occur when handling the instrument. The user shall observe all listed counter measures in order to achieve and maintain the lowest possible level of hazard.

Additional warning messages can be found whenever actions and situations described in this manual are related to situational hazards.

	<p>! WARNING</p> <p>Death or serious injuries by formation of explosive atmospheres inside the instrument.</p> <ul style="list-style-type: none"> • Before operation, check all gas connections for correct installation • Regularly discharge the waste bottle to avoid overflow • Check for proper system tightness
	<p>! DANGER</p> <p>Death or serious injuries by use in explosive environments.</p> <ul style="list-style-type: none"> • Do not store or operate the instrument in explosive environments • Provide sufficient ventilation and make sure to directly withdraw fumes
	<p>! WARNING</p> <p>Death or serious burns by flammable vapors.</p> <ul style="list-style-type: none"> • Remove all sources of flammable vapors • Do not store flammable chemicals in the vicinity of the device
	<p>! CAUTION</p> <p>Risk of burns by hot heating block and extraction cells.</p> <ul style="list-style-type: none"> • Do not touch hot parts or surfaces • Let the system and inserted extraction cells cool down safely • Do not move the instrument or parts of it when hot

	NOTICE
	<p>Risk of instrument damage by liquids or mechanical shocks.</p> <ul style="list-style-type: none"> • Do not spill liquids over the instrument or its components • Do not move the instrument when it is loaded with sample liquid • Do not drop the instrument or its components • Keep external vibrations away from the instrument • Safely attach the instrument to the bench in earthquake prone regions • Do not operate the instrument without the safety shield installed
 	NOTICE
	<p>Risk of instrument damage by wrong mains supply.</p> <ul style="list-style-type: none"> • External mains supply must meet the voltage given on the type plate • Check for sufficient grounding



2.5.2 Warning labels on housing and assemblies

The following warning sticker(s) can be found on the housing or assemblies of the SpeedExtractor:

Symbol	Meaning	Location
	Hot item, hot surface	Sticker/label, located at the heating block

2.5.3 Personal protective equipment

Always wear personal protective equipment such as protective eye goggles, protective clothing and gloves. The personal protective equipment must meet all requirements of the supplementary data sheets for the chemicals used.

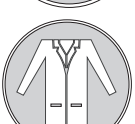
   	WARNING
	<p>Serious chemical burns by corrosives.</p> <ul style="list-style-type: none"> • Observe supplementary data sheets of all used chemicals. • Handle corrosives in well ventilated environments only. • Always wear protective goggles. • Always wear protective gloves. • Always wear protective clothes. • Do not use damaged glassware.

2.5.4 Built-in safety elements and measures

- The heating element is equipped with overtemperature protection which is activated at $260\text{ °C} \pm 10\text{ °C}$.
- The pressure parts are protected by a mechanical pressure control valve which is activated at $200\text{ bar} \pm 20\text{ bar}$.
- To start a program at least one extraction position must be activated.
- Safety shield sensor: To start an extraction the protection shield must be closed.
- Vial rack sensor: To start an extraction the vial rack must be installed.
- The presence of extraction cells in the heating block is checked in the tightness test at the beginning of each extraction process.

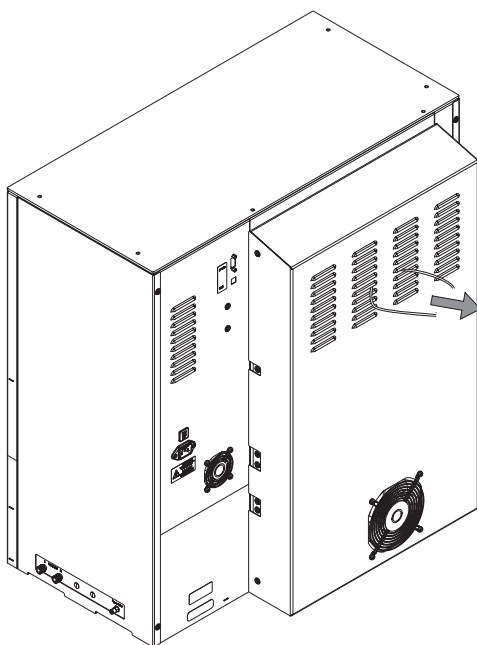

Seismic tie-down

In earthquake-susceptible regions the instrument should be tied down by the ventilation slot on the rear of the instrument.

2.6 General safety rules

Responsibility of the operator

The head of the laboratory is responsible for training his/her personnel.

The operator shall inform the manufacturer without delay of any safety-related incidents which might occur during operation of the instrument or its accessories. Legal regulations, such as local, state and federal laws applying to the instrument or its accessories must be strictly followed.

Duty of maintenance and care

The operator is responsible for the proper condition of instrument. This includes maintenance, service and repair jobs that are performed on schedule by authorized personnel only.

Spare parts to be used

Use only genuine consumables and spare parts for maintenance to assure good system performance, reliability and safety. Any modifications of spare parts or assemblies are only allowed with the prior written permission of the manufacturer.

Modifications

Modifications to the instrument are only permitted after prior consultation and with the written approval of the manufacturer. Modifications and upgrades shall only be carried out by an authorized BUCHI technical engineer. The manufacturer will decline any claim resulting from unauthorized modifications.

3 Technical data

This chapter introduces the reader to the SpeedExtractor and its main components. It contains technical data, requirements and performance data.

3.1 Scope of delivery

Check the scope of delivery according to the order number and your shipping note.

NOTE

For detailed information on the listed products, see www.buchi.com or contact your local dealer.

3.2 Instrument configurations

The SpeedExtractor is available in 21 different configurations differing in the number of positions (E-916: 6 positions, E-916XL: 6 position, E-914: 4 positions), the type of solvent mixer (2 ports or 4 ports), and the size of the extraction cells (E-916: 10–40 mL, E-916XL: 60 mL, E-914: 10–120 mL). The SpeedExtractor E-914 is available with and without pedestal (the pedestal allows to accommodate large volume collection recipients).

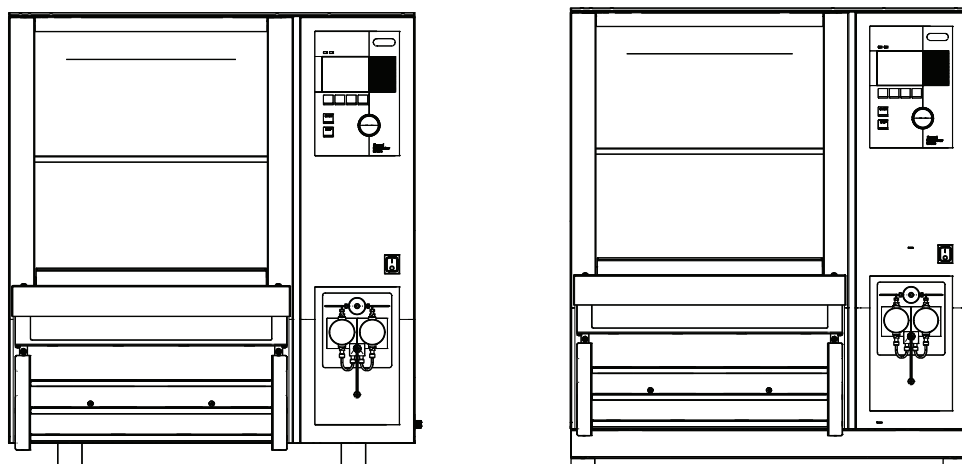

E-914 without and with pedestal

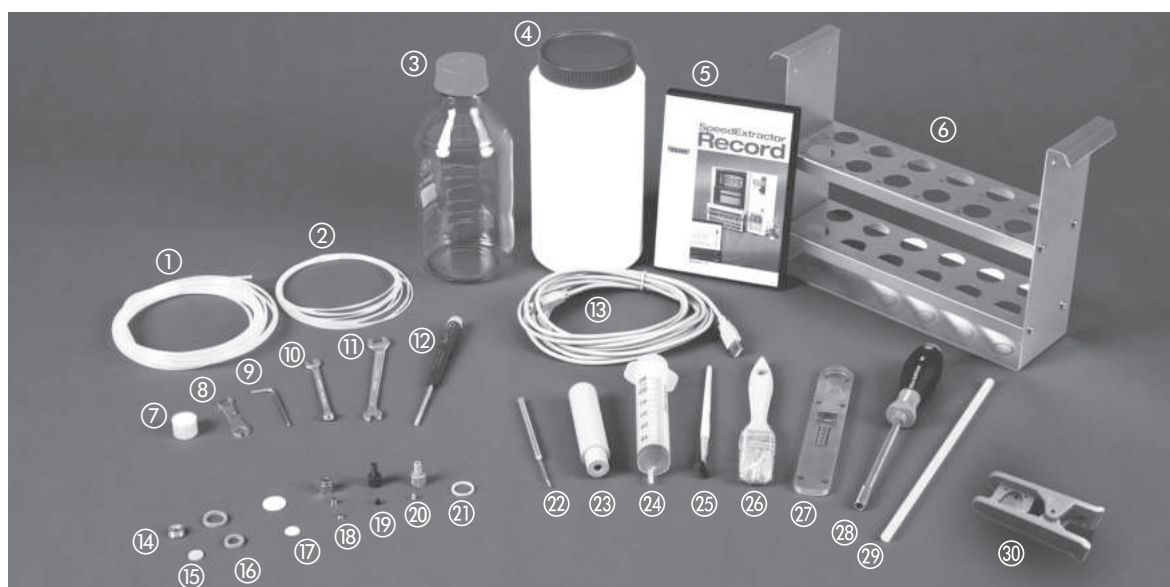
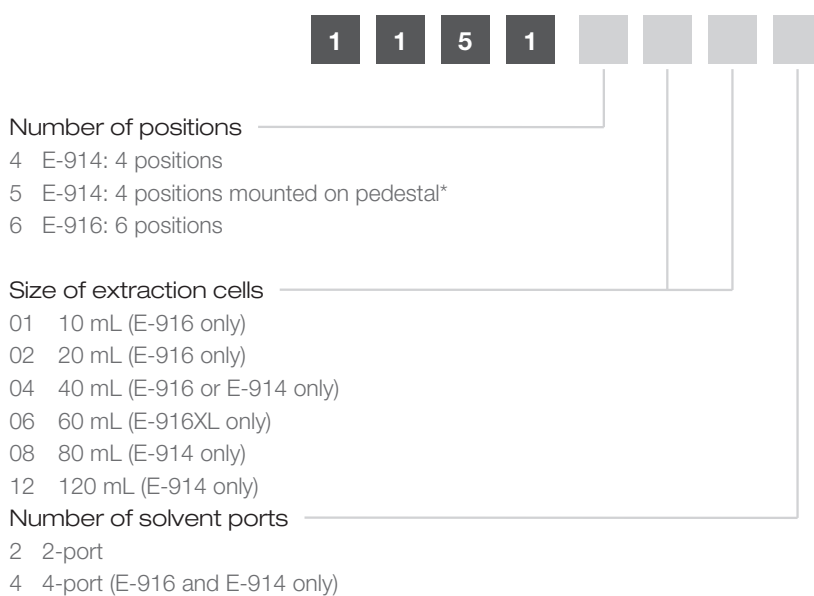

List of loose parts

Position	Item	PU	Universal	Order no. E-914	Order no. E-916	Order no. E-916XL
①	FEP tube D3.2/1.6, 5 m	2	11055604			
②	FEP waste tube 1/16", 0.5 m	4/6	053303			
③	Solvent bottle 1 L	1	053203			
④	Quartz sand 0.3–0.9 mm, 2.5 kg	1	037689			
⑤	Extraction Record demo license	1	053074			
⑥	Extraction cell carrier	1		053691	053690	11069547
⑦	Solvent filter	4	044340			
⑧	Turix wrench	1	044349			



List of loose parts

Position	Item	PU	Universal	Order no. E-914	Order no. E-916	Order no. E-916XL
⑨	Allen wrench 3 mm	1	000610			
⑩	Spanner wrench 1/4"	1	053204			
⑪	Spanner wrench 8/10 mm	1	053608			
⑫	Torx screwdriver TX20	1	053668			
⑬	USB cable 2.0 A-B, 4.5 m	1	049226			
⑭	Plug screws	2	053209			
⑮	Metal frit	25	049568			
⑯	Cup seals, top	12		053671	053669	11069763
⑯	Cup seals, bottom	12	053670			
⑰	Cellulose filter, top	100		051249	049572	11069533
⑰	Glass fiber filter, bottom	100	11055932			
⑱	Swagelok nut and ferrules 1/8"	1	11055342			
⑲	UNF-28 Fitting 1/8", green	10	053663			
⑲	UNF-28 Ferrule 1/8", green	10	053664			
⑳	UNF-28 Fitting 1/16", gray	25	044816			
⑳	UNF-28 Ferrule 1/16", gray	25	044269			
㉑	Supporting ring PEEK	2		053667	053666	11069769
㉒	Filter hook	1	053316			
㉓	Plunger	1		053038	053037	11069530
㉔	Syringe 60 mL	1	034882			
㉕	Brush small	1	053256			
㉖	Brush large	1	053257			
㉗	Gripper extraction cell	1		053026	053030	11069534
㉘	Bit wrench	1	052783			
㉙	Extruder rod	1	11055284			



List of loose parts

Position	Item	PU	Universal	Order no. E-914	Order no. E-916	Order no. E-916XL
③⑩	Tube cutter	1	019830			

3.3 Materials used

Component	Material designation
Housing SpeedExtractor	Stainless steel
Lines to pump	FEP
Solvent valve	PEEK, FFPM
Mixer	PEEK, FFPM
Media valve	PEEK, PTFE
Lines to and from heating block	Stainless steel
Pressure gauges	Stainless steel
Position valves	Stainless steel, PTFE
Outlet valves	PEEK, PTFE
Heating block	Aluminum
Heating block cover	PTFE
Cup seals	PTFE
Extraction cells	Stainless steel
Lines to waste	FEP
Needles	Stainless steel
Collection vials	Glass
Septa for vials	Silicon, PTFE
Collection unit	Stainless steel, POM
Pump	PTFE, ceramic, stainless steel
Protective shield	Glass, POM

3.4 Technical data overview

Technical data of the SpeedExtractor	
Description	Technical data
Dimensions (W×H×D)	670×725×500 mm
Weight	90 kg
Connection voltage	100 – 240 VAC ±10 %
Max. power consumption	max. 1750 W
Mains connection	3-pole (P, N, E) via power cord
Frequency	50/60 Hz
Fuse	14 A/240 V
Interface	USB 2.0
Installation category	II
Degree of protection	IP21
Pollution degree	2
Temperature control range	30 – 200 °C
Temperature accuracy	±3 °C
Pressure range	50 – 150 bar
Pressure accuracy	±5 bar
Primary pressure nitrogen connection	6 – 10 bar
Flow rate pump	1 – 50 mL/min
Precision flow rate	±2 %
Precision mixer	±2 % (±5 % for isopropanol)
Extraction cell size	E-916: 10, 20, 40 mL E-916XL: 60 mL E-914: 10*, 20*, 40, 80, 120 mL
Environmental conditions	For indoor use only
Temperature	5 – 40 °C
Altitude	up to 2000 m
Humidity	maximum relative humidity 80 % for temperatures up to 31 °C, and then linearly decreasing to 50 % at 40 °C
Noise level	<70 dB

*Accessories

4 Description of function

This chapter explains the basic principle of the SpeedExtractor E-916 / E-914 and provides a functional description of the assemblies.

4.1 Functional principle

The SpeedExtractor E-916 / E-914 is an automated instrument for parallel extraction of primarily organic compounds from a variety of solid or semi-solid samples. Conventional methodologies are accelerated by using a solvent at elevated temperatures. In order to maintain the solvent in a liquid state during the extraction process, the solvent inside the extraction cell is put under pressure. Generally, to achieve high recoveries multiple extraction cycles are applied. Once the extraction step is finished, the extracts are cooled down in a cooling unit and flushed into collection vials which then can easily be evaporated in parallel using the Multivapor™ P-6 or Syncore Analyst R-12. Hence the whole process workflow can be performed in parallel with up to 6 samples.

The SpeedExtractor E-916 can be used for 6 samples with a maximum volume of 40 mL. The SpeedExtractor E-916XL can be used for 6 samples with a volume of 60 mL. The SpeedExtractor E-914 can be used for up to 4 samples with a limited maximum volume of 120 mL. The total volume of the collection recipients are from 60 mL vials to 240 mL bottles. Using a specially designed rack, it is also possible to use large volume round bottom flasks to collect the extracts.

Typical applications are carried out in environmental substances (environmental pollutants such as those listed in EPA Method 3545A for instance), food (recovery of fat from meat, oil seeds, feeds, dairy products, snack foods, etc.), pharmaceuticals (extracting analytes from natural products, drugs from drug formulations, pharmaceutical additives from feeds) and polymers (monomeric compounds, oligomers or additives).

4.2 Overview of the instrument

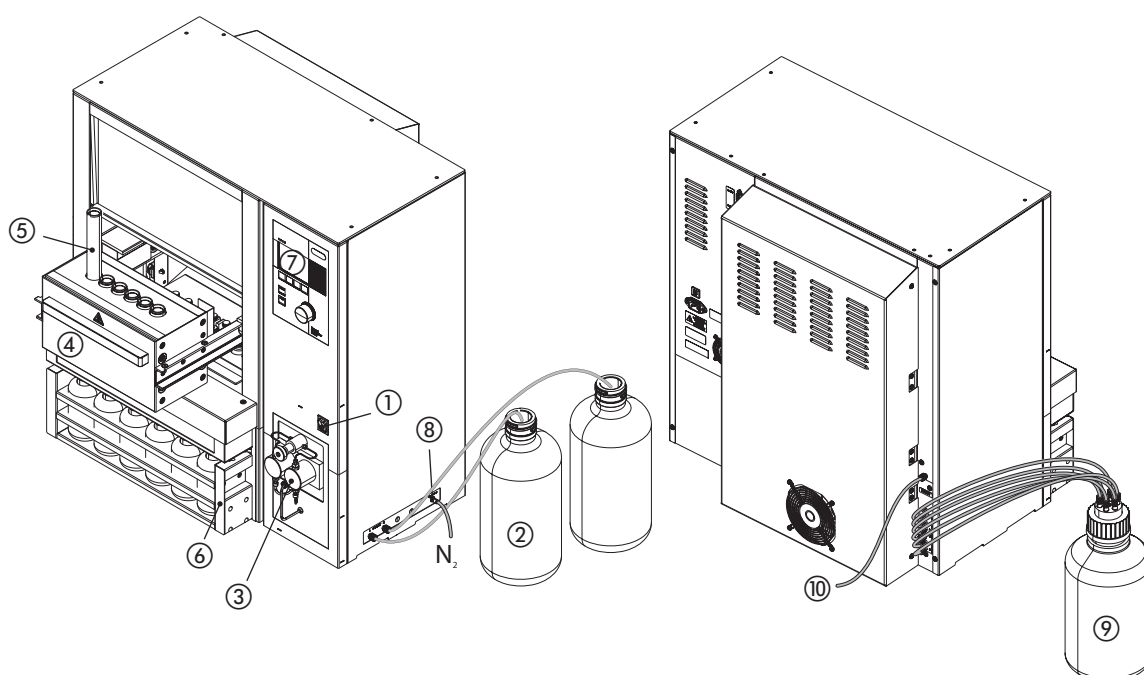

① Main power switch

The instrument is protected by a 14 A (240 V) circuit breaker. The main fuse button at the rear of the instrument must be pushed in.

② Solvent reservoir

The maximum possible number of solvent bottles depends on the type of mixer. With the 2-port mixer up to 2 different solvents, with the 4-port mixer up to 4 different solvents can be connected allowing any user-defined solvent ratios.

③ Solvent pump and solvent mixer

A self-priming HPLC pump transfers the extraction solvent from different solvent reservoirs to the mixer and from there into the extraction cell. With the control panel arbitrary solvent ratios can be chosen.

④ Heating block

The heating block accommodates 6 or 4 extraction cells and guarantees an accurate and uniform heat distribution across all extraction positions independent of the placement. The whole block is easily pulled out horizontally facilitating the accommodation of the extraction cells. Magnetic connections on the heating block and on guide rail make sure that the heating block is correctly placed in a defined middle position, ready for operation. The protection shield protects the operator from hot surfaces and movable parts during operation.

⑤ Extraction cells

The extraction cells are tailored to the dimensions of the holes in the heating block guaranteeing an efficient and accurate heat transfer into the sample. The sample volume of the cells differs from 10 – 40 mL for the E-916, 60 mL for the E-916XL and from 10 – 120 mL for the E-914.

⑥ Collection rack

Up to 6 collection vials are loaded into the collection unit. After extraction, the extracts containing the analytes are collected in these bottles. Different collection units and adapters are available to accommodate small vials up to large volume round bottom flasks. See chapter 10.

⑦ Control panel

The control panel containing a liquid crystal display (LCD) and membrane keypads allows to program the full extraction process. Detailed schematic representations inform the operator about the current stage of the process as well as possible errors.

⑧ Nitrogen inlet

The nitrogen gas inlet connection is located on the right hand side next to the solvent connections. It is used to get rid of residual solvent by flushing the lines and cells thoroughly with nitrogen and/or to inerting the system. Inerting the receiving vials is for the stability of some analytes beneficial. Nitrogen pressure of 6 – 10 bar is required for proper operation. To avoid any contamination by flushing with nitrogen 5.0 quality (i.e. vol.-% > 99.999) is recommended for trace analysis and 4.5 (i.e. vol.-% > 99.995) for other applications.

⑨ Waste outlets

An 18-port valve located between the heating block and the collection rack allows collecting the extract leaving the extraction cells either in the collection bottle or a waste bottle. The latter is in particular beneficial when the solvent is changed or the lines are flushed upon contamination. The number of waste outlets is determined by the instrument configuration! The E-916 features 6, the E-914 only 4 outlet ports.

⑩ Exhaust

The collection vials are sealed by septum. A stainless steel needle pierces this septum allowing the extract to flow from the extraction cell into the collection bottle. To compensate the pressure a second needle connects the collection bottle with an exhaust joint situated on the rear of the instrument.

4.3 Overview of the extraction process

A complete extraction process involves the following phases:

Phase 1: Preparation

- Creating an extraction method (see section 6.2.3).
- Preparing the instrument for operation. This involves filling the solvent reservoirs and preheating the instrument to the temperature of operation (equilibration), see section 6.2.3.
- Packing the extraction cell with the sample (see section 6.2.3).
- Placing the collection vials in the collection tray (see section 6.4.1).
- Placing the extraction cell into the preheated heating block (see section 6.4.1).

Phase 2: Extraction cycles

- Start extraction method (see section 6.4.8).

An extraction cycle involves three steps with a user-defined time period (except for HEAT UP):

In a first HEAT UP step the pressure and temperature inside the extraction cell is slowly increased to the set parameters of extraction program.

During HOLD step these parameters remain constant. This corresponds with the literal extraction step at constant temperatures and pressures. After this step the outlet valve opens and the liquid extract is DISCHARGED and collected in collection vials or a waste bottle by means of pressure compensation. All three steps are repeated several times according to the extraction program. A complete run may consist of 1 – 10 extraction cycles. The presence of extraction cells is checked in the TIGHTNESS TEST at the beginning of each extraction process.

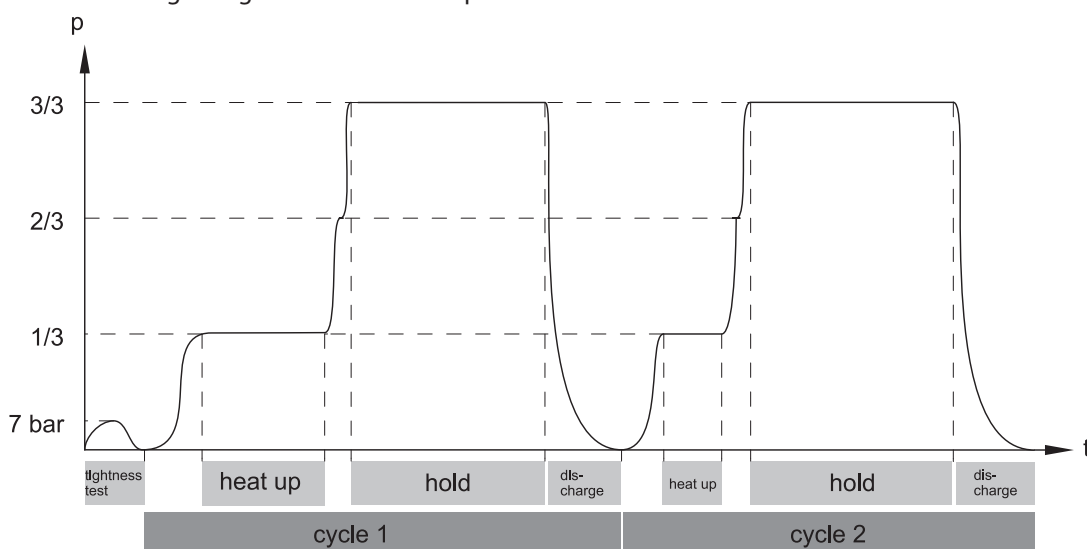

The HEAT UP step is not accessible by the user but is determined by the instrument software. The absolute time of this period depends on the temperature, pressure, size of the extraction cell and type of sample. Additional time is needed to fill the extraction cell. The HOLD and the DISCHARGE time can be defined by the user individually for each cycle.

The actual time used for a complete process is shown in the STATUS menu and/or recorded by SpeedExtractor Record software, where it can be exported to a report and printed out.

Phase 3: Flushing the lines and unloading the heating block

- Flushing the lines with fresh solvent and collecting the liquid in the collection vials (see section 6.4.2).
- Flushing with nitrogen to remove residual solvent (see section 6.4.2).
- Unloading the heating block (see section 6.4.9).

NOTE

Preheating the instrument to the temperature of operation prior to loading it with the extraction

cells is absolutely mandatory. Placing the cells in the cold instrument followed by heating up the closed system might damage the cup seals. It is therefore crucial to note that the temperature of the instrument must not be changed once the system is closed. The instrument is ready once the set temperature is reached (which is shown in the main display) and the extraction process is started by pressing START. In order to achieve reproducible results, it is recommended that the same procedure always be followed. As the time used to reach the set temperature is depending on the absolute set temperature, it is suggested that the extraction cells never be placed in the heating block until the instrument is ready and to start the extraction process right away. This procedure guarantees that the sample is not unnecessarily exposed to the hot environment and that this time period before the actual process starts does not significantly influence the recovery of the extraction process.

In addition, placing extraction cells in all positions is highly recommended even though not all positions are used. This improves the heat uniformity of the heating block. It is possible to deactivate the positions with the empty cells to avoid needless solvent consumption.

4.4 Schematic representation of the process

The following illustration provides a schematic representation of the pathways of the different media for the E-916. Up to four different solvents ① and nitrogen ② are connected to the E-916. A media valve ⑥ switches between solvent and nitrogen. The mixer ④ mixes the solvents that are selected with the help of the solvent valves ③.

The pump ⑤ transfers the solvent mixture to divider ⑦ where it is equally distributed to each of the activated positions. Once the system is sealed by closing the extraction cells ⑫ with the upper and lower tightening device that holds the cup seals ⑪ and ⑬, the outlet valve ⑮ is closed in order to increase the pressure inside the system. The pressure of each position is displayed by the pressure sensors ⑩. When the set pressure is reached (at the end of the heat-up step) the position valves ⑨ are permanently closed, and the sample is extracted (hold step). In the discharge step the outlet valve ⑮ opens, the hot mixture is cooled down by the cooling units ⑭ and finally transferred to the collection vials ⑯. Pressure compensation is achieved by the lines to the exhaust ⑰. In case of an overpressure, the outlet valve opens and releases solvent into the collection vials. Residual solvent is optionally flushed with fresh solvent. An additional thorough flushing step with nitrogen removes residual solvent in the lines. In addition, another optional flushing with solvent into waste instead of the collection vials is possible by setting the outlet valve to waste ⑱. This is usually done to prepare the system for another run with a different solvent. For a thorough description of each step please refer to section 6.4.

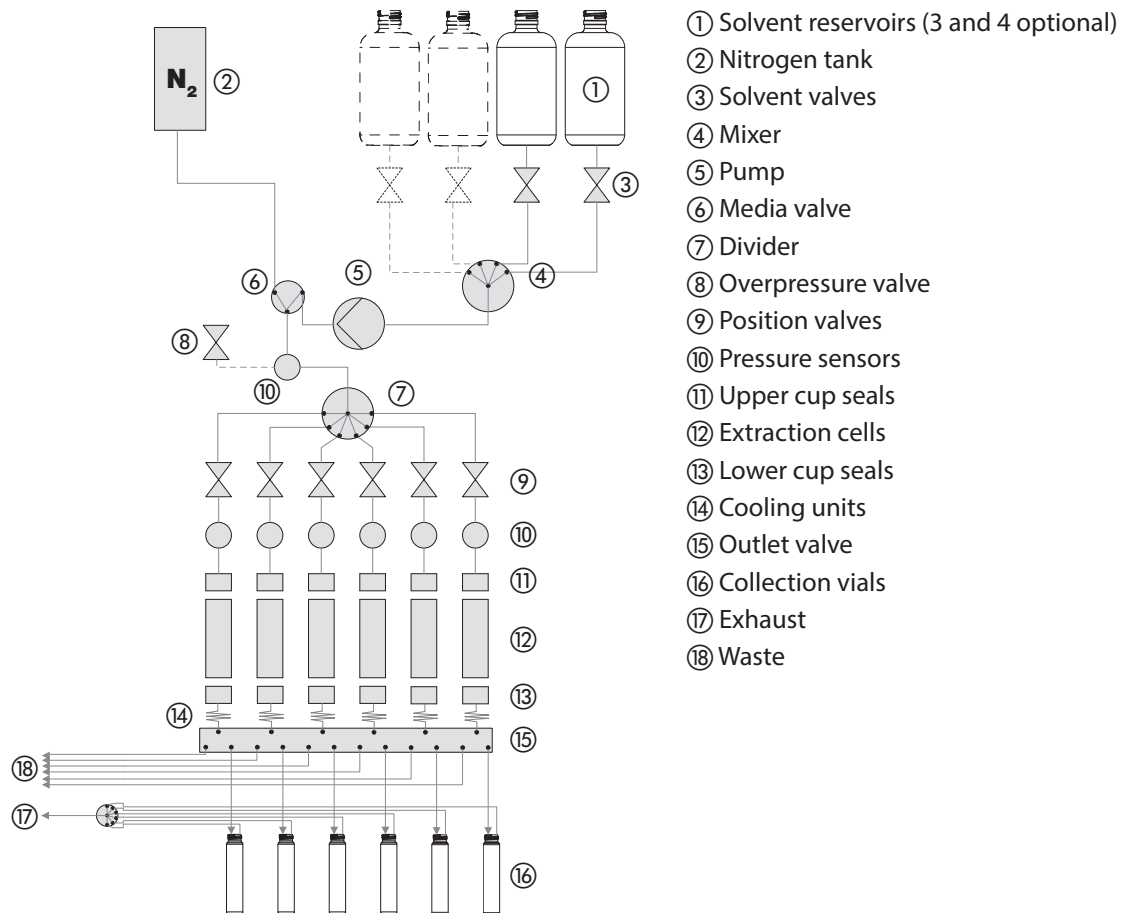

4.5 Controls and connections

4.5.1 Instrument controls

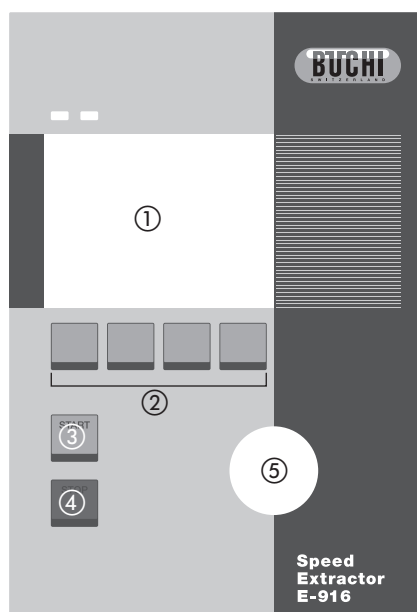

- ① Display to view the instrument software.
- ② Function buttons to operate the instrument software.
- ③ START button to start an extraction.
- ④ The STOP button comprises 3 functions:
 - press once: pause the process and continue by pressing START again
 - press twice: interrupts the process and continues with flushing using solvent and gas
 - press three times: stops the process immediately, i.e. the system remains at the very position of the process
- For more information see section 6.4.8.
- ⑤ Selection knob to define values within the instrument software.

NOTE

The START and STOP buttons are used only for the extraction method but have no effect on functions such as preheat, leak test, or flush. All functions apart from extractions are initiated by function buttons ②.

4.5.2 Main displays of the instrument

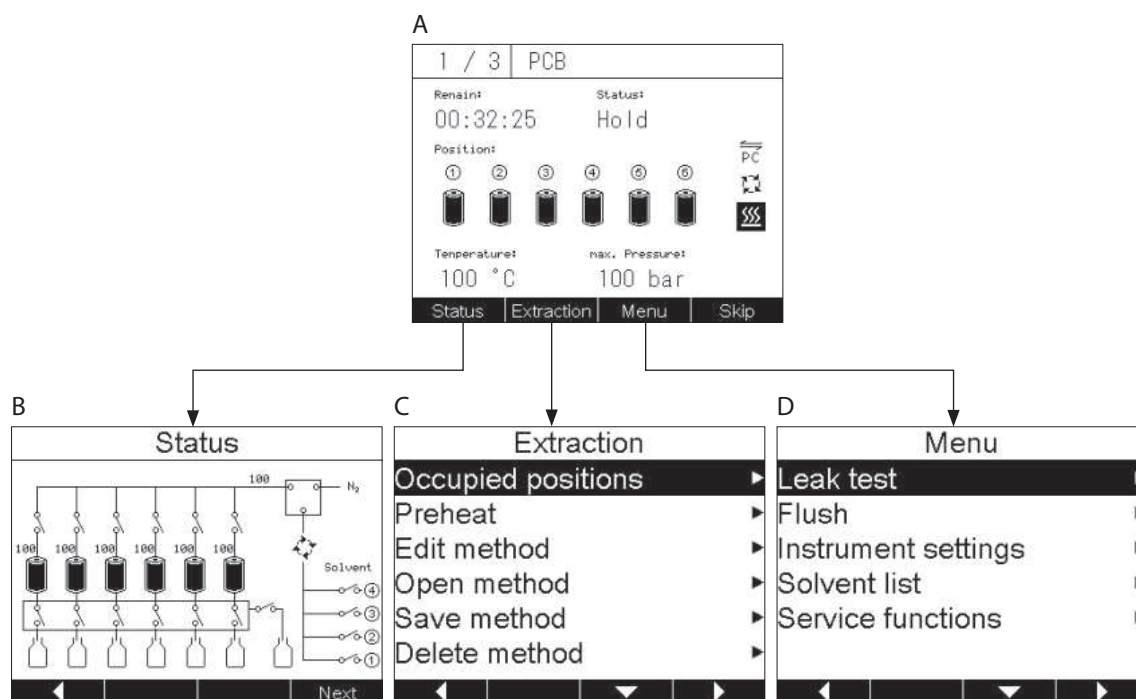

A The main display shows the most important parameters of the extraction process, such as the activated positions in the heating block, the maximum pressure at the position valves, the temperature of the heating block, the number of extraction cycles, as well as the current cycle and the time remaining to the end of the process. The status and total remaining time are also shown in the main display. With the function buttons the three main displays STATUS, EXTRACTION and MENU are accessible.

B STATUS shows a diagram of the lines, valves, solvent reservoirs, extraction cells, and collection vials of the instrument. The valves open and close according to the stage of the method and the number of activated positions. As the name already indicates, this menu is very beneficial to get a quick overview of the current status of operation.

C EXTRACTION is used to edit and save a new method or to open or delete an existing method. It also includes two functions that are required prior to operation: activation of the extraction positions (OCCUPIED POSITIONS) and preheating of the instrument to the operating temperature (PRE-HEAT).

D MENU involves all functions that are not directly involved in an extraction method but are typically used at start-up, during maintenance, and service, and for product information.

These four main displays contain the following elements:

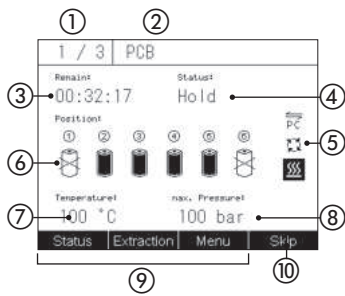

- ① Current extraction cycle/total extraction cycles
- ② Name of the current extraction method. When the name is crossed out (~~DEFAULT~~), the current method has been changed and not yet saved (see section 6.4.3).
- ③ Total remaining time of the extraction process.
- ④ Status: PREHEAT, READY, all methods steps, PAUSE, and ABORT.
- ⑤ System symbols like HEATING (🔥), PUMPING (🔄) or PC CONNECTION (PC) are reversed or in case of PUMPING rotating when being active.
- ⑥ Extraction positions. When the symbol is crossed out the corresponding position is deactivated (see section 6.4.2).
- ⑦ Temperature of the heating block.
- ⑧ Maximum pressure.
- ⑨ Function buttons for the STATUS, EXTRACTION and MENU submenus.
- ⑩ To skip extraction steps or to stop running leak test

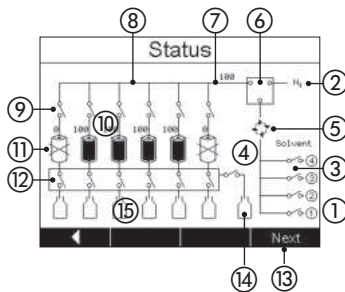

- ① Solvent reservoirs (2 or 4 ports depending on the mixer)
- ② Nitrogen tank
- ③ Solvent valves
- ④ Mixer
- ⑤ Pump
- ⑥ Media valve
- ⑦ Overall pressure sensor
- ⑧ Divider
- ⑨ Position valves
- ⑩ Pressure sensors for each extraction position
- ⑪ Extraction cells (E-916: 6 pos.; E-914: 4 pos.)
- ⑫ Outlet valve: Discharging into waste or collection vials
- ⑬ NEXT opens a submenu where the progress of extraction run is shown (see below).
- ⑭ Waste bottle
- ⑮ Collection vials

Progress	
① Time to Cycle end	00:03:11
② Time to Change vial	--:--:--
③ Time to End	00:19:41
Back	
End	

- ① Remaining time to finish the current extraction cycle.
- ② Remaining time for the next manual override, i.e. exchange of the collection vials. This only applies to methods where the function VIAL CHANGE is activated (see section 6.4.3).
- ③ Total remaining time to finish the extraction run.
- ④ BACK goes to the previous STATUS overview.
- ⑤ END goes back to the main display.

Extraction	
① Occupied positions	▶
② Preheat	▶
③ Edit method	▶
④ Open method	▶
⑤ Save method	▶
⑥ Delete method	▶

- ① Definition of the number of positions (see section 6.2.4).
- ② Heating up the instrument to operation temperature (see section 6.2.3).
- ③ Editing an existing (or default) extraction method (see section 6.4.3).
- ④ Open an existing extraction method (see section 6.4.6).
- ⑤ Save a previously edited extraction method (see section 6.4.3).
- ⑥ Delete an existing extraction method (see section 6.4.3).

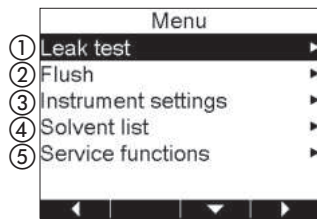

- ① Performing a LEAK TEST (see section 6.2.5).
- ② Flushing the lines with solvent in collection vials or a waste bottle. Parameters like time, flow rate and solvent mixtures are defined in submenus (see section 6.2.6).
- ③ Defining instrument settings like language, contrast of the display, acoustic signals, preheat demand when the instrument is turned on.
- ④ SOLVENT LIST shows the default solvent list which includes the 10 most frequently used solvents. This list can be edited and modified as needed (see section 6.2.2).
- ⑤ The SERVICE FUNCTIONS submenu provides access to main instrument components for first quick trouble shooting purposes. All valves can individually be opened or closed. All safety sensors which check the position of the heating block, safety shield or collection rack as well as all pressure sensors are listed. The pump can be directly operated with different flow rates. With the help of a flow test faulty lines can easily be located. The lift of the heating block and collection rack can be driven independently. The performance of the fan can be changed. Information about instrument and operating hours are shown. For further information see section 8.2.

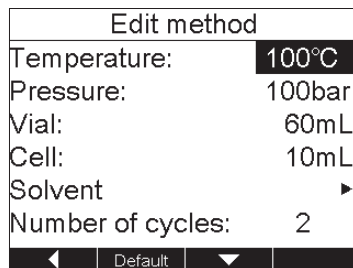

NOTE

Some submenus contain hidden lines as it is not possible to show all information on the display. In this case a scroll bar on the right hand side indicates the presence of hidden lines. Move down with down button to get access to this information.

4.5.3 General information on buttons

The following control buttons are available in the software for navigation and input configuration:

Extraction	Open the extraction menu
Menu	Open the menu functions like leak test, instrument settings etc.
Status	Open the status menu
Back	Get back to the previous screen
Next	Get on to the next screen or entries of a screen
End	Leave the current screen and get back to the main display
ESC	Get back to the start screen without saving possible settings
◀	Backward button to move backward within the submenu structure
▶	Forward button to move forward within the submenu structure
▲	Move up within the entries of a screen
▼	Move down within the entries of a screen
Yes	Affirm a screen message
No	Negate a screen message
On	Switch on the position or function
Off	Switch off the position of function
All on	Switch on all extraction positions
Copy	Copy the entry of currently active parameter of the extraction method to the LEAK TEST or copy the entries of an extraction cycles
Paste	Paste the entries of a copied extraction cycle to a new cycle
START	Start process except for the extraction process (leak test, flush etc.)
List	Open the solvent list to select a default solvent
Edit	Edit the name of a solvent in the solvent list or the entries of an extraction cycle
Delete	Delete all characters of an entry when naming a solvent/program
Select	Confirm the selection of a character when naming a solvent/program
Accept	Save a solvent/program under the entered name
Default	Load the predefined solvents by replacing the first 10 entries of the list
Up	Move lift (heating block or rack) up
Down	Move lift (heating block or rack) down
Stop	Stop moving the lift
Skip	Skip an extraction step or stop the running leak test

4.5.4 Rear connections

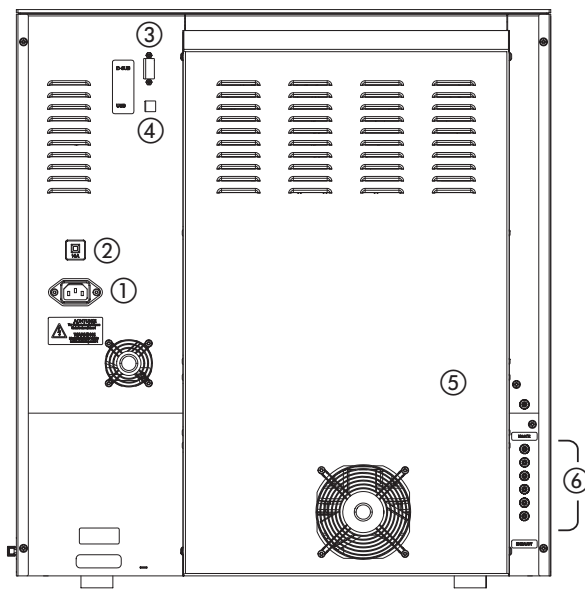

- ① Mains supply
- ② Main fuse
- ③ RS232 port
- ④ USB 2.0 port
- ⑤ Exhaust outlet for purging with nitrogen, discharge and tightness test
- ⑥ Waste outlet for flushing with solvent or collecting extracts

4.5.5 Side connections

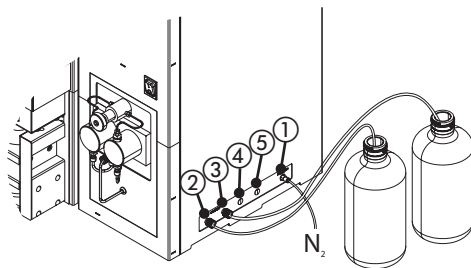

- ① Nitrogen inlet
- ② Solvent 1
- ③ Solvent 2
- ④ Optional (with 4-port mixer only): solvent 3
- ⑤ Optional (with 4-port mixer only): solvent 4

5 Putting into operation

This chapter describes the installation of the SpeedExtractor and gives instructions on initial start-up.

NOTE



Inspect the instrument for damages during unpacking. If necessary, prepare a status report immediately to inform the postal company, railway company or transport company. Keep the original packaging for future transport.

5.1 Installation site

Put the instrument on a stable, horizontal surface. Consider the maximum product dimensions and weight. Obtain the environmental conditions as described in section 3.4, technical data.

Installation prerequisites:

- Do not place any objects on top or below the instrument or parts of it.
- The instrument must be installed with 5 cm clearance to any other objects or walls to allow sufficient cooling.
- Do not store containers, chemicals or other items behind the instrument.

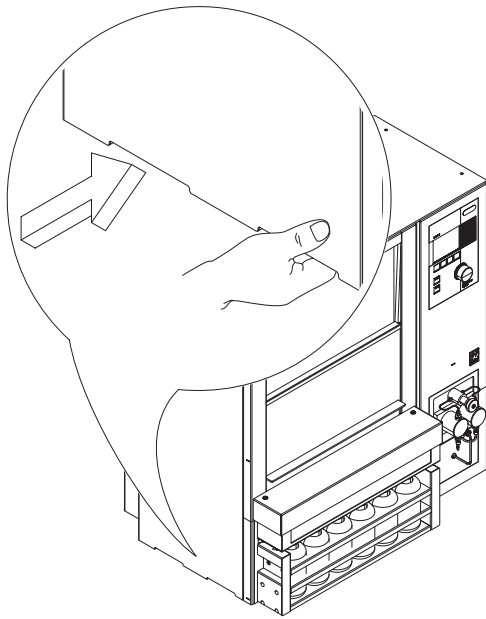

	<p>WARNING</p> <p>Death or serious injuries by use in explosive environments.</p> <ul style="list-style-type: none"> • Do not operate the instrument in explosive environments • Do not operate the instrument with explosive gas mixtures • Before operation, check all gas connections for correct installation • Directly withdraw released gases and gaseous substances by sufficient ventilation
	<p>CAUTION</p> <p>Risk of minor or moderate injury by heavy weight of the instrument.</p> <ul style="list-style-type: none"> • Consult three further persons to transport the instrument • Do not drop the instrument • Place the instrument on a stable, even and vibration-free surface • Keep limbs out of crushing zone
	<p>NOTICE</p> <p>Risk of instrument damage by liquids or mechanical shocks.</p> <ul style="list-style-type: none"> • Do not spill liquids over the instrument or its components • Do not move the instrument when it is loaded with sample liquid • Do not drop the instrument or its components • Keep external vibrations away from the instrument • Safely attach the instrument to the bench in earthquake prone regions • Do not operate the instrument without the protection cover installed at the front

**NOTE**

The instrument does not have to be operated under a fume hood but the exhaust must lead into some kind of ventilation device.

Never hold the instrument on the collection rack or pump heads to move the instrument. Always use the handles on the side.

5.2 Electrical connections

NOTICE	
 	<p>Risk of instrument damage by wrong mains supply.</p> <ul style="list-style-type: none"> • External mains supply must meet the voltage given on the type plate • Check for sufficient grounding

NOTE

- External connections and extension lines must be provided with a grounded conductor lead (3-pole couplings, cord or plug equipment). All used power cords must meet the input power requirements.

5.3 Gas and solvent connections

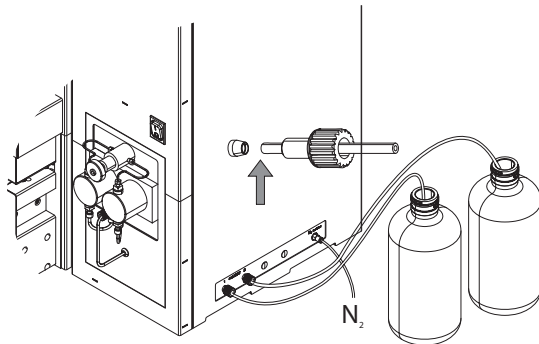



- Connect nitrogen gas by means of the provided hose. The corresponding joint contains a quick-lock mechanism. The nitrogen gas connection is located on the right hand side panel. The required pressure range is 6 – 10 bar. This pressure has to be set at the external pressure reduction valve.
- Connect the other end of the nitrogen line to a nitrogen tank by means of the provided 1/8" Swagelok brass nut and ferrule (P/N 11055342).
- Connect the solvent reservoirs on the right hand side panel. Make sure that the ferrule is pointed towards the fitting to avoid leaking, and flush with the end of the tubing.

NOTE

Close vacant ports with a blind fitting (P/N 035665) to avoid any unwanted contamination.

Never use technical grade solvent. It is strongly recommended to use p.a. quality or HPLC grade solvents. To avoid contamination by the nitrogen use 5.0 quality for trace analysis and 4.5 for other applications.

	NOTICE
	<p>Risk of instrument damage by excess pressure within the instrument.</p> <ul style="list-style-type: none"> • Make sure that the maximum pressure of the nitrogen does not exceed 10 bar

	NOTICE
	<p>Risk of instrument damage by dry running instrument parts, especially valves.</p> <ul style="list-style-type: none"> • Never run the instrument or parts of it without any solvent

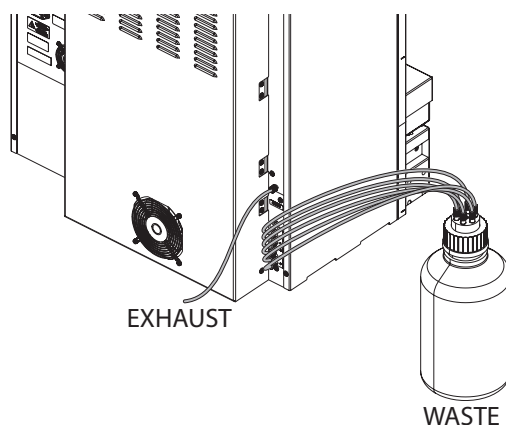

- Connect the EXHAUST and WASTE outlets on the back of the instrument accordingly.

5.4 Dehydration

NOTE

At initial start-up or after a long period of no use (>1 month), the instrument should be dehydrated for proper operation. To do so, heat up the instrument to 100°C for 1 hour (heater open, no cells). Proceed as described in section 6.3.2.

5.5 Functional test

To make sure that the installation procedure has been carried out properly and the system is tight, carry out a leak test (see section 6.2.5) before putting the instrument into operation for the first time.

6 Operation

This chapter explains the operating elements and possible operating modes. It gives instructions on how to operate the SpeedExtractor properly and safely.

The following table provides a quick overview of main step typically being involved in an extraction:

Overview of main step typically being involved		
Step	Action	Section
1	Create a new method with default operating parameters	6.4.3
2	Preheat the instrument	6.2.3
3	Activate the positions	6.2.4
4	Flush the system (optional)	6.2.6
5	Activating the EcoMode (optional)	6.2.7
6	Prepare the sample	6.3.1
7	Select an extraction cell size	6.3.2
8	Pack the extraction cell	6.3.3
9	Insert the sample and collection vials	6.4.1
10	Run the process	6.4.8
11	Optimize the process (optional)	6.4.7
12	Flush the system with the solvent used for the next run (optional)	6.2.6

6.1 Method development

A method must be developed before beginning an extraction to define the operating parameters for a run. When developing a new method it is often advisable to collect the extracts of the first three cycles followed by a vial change for the fourth cycle. If the second collection vial does not contain any analyte the vial change is shifted between the second and third cycle. Depending on the amount of analyte found in the second vials, optimization of the extraction time is recommended. For further information regarding the vial change, see section 6.4.3.

Further information about how to optimize the extraction process is given in section 6.4.7. BUCHI's SpeedExtractor Application booklet and Application notes give detailed information about method development and method parameters for a wide range of applications. Please contact your local dealer or BUCHI for these documents.

6.2 Preparing the instrument

This section involves all steps required to make the instrument ready for operation.

	! WARNING
	Death or serious poisoning by contact or incorporation of harmful substances at use.
	<ul style="list-style-type: none"> • Before operation, check the instrument for correct assembling • Before operation inspect sealings and tubes for good condition and tightness • Exchange worn out or defective parts immediately • Provide sufficient ventilation and make sure to directly withdraw fumes

6.2.1 Solvent reservoir

As already mentioned, when developing a new method, select a solvent or solvent mixture that is already known from a classical method such as Soxhlet extraction or another high pressure method such as ASE. Generally, the analytes should show high solubility in the extraction liquid, but not the sample matrix.

Do not use solvents with an self ignition point of 40 to 220 °C.

Particularly, do not use the following solvents with the SpeedExtractor. If there is any question about solvent suitability, contact BUCHI.

Solvents NOT being compatible with the process		
Component	Formula	Reason
Carbon disulfide	CS ₂	Autoignition temperature 100 °C
Diethyl ether	C ₄ H ₁₀ O	Contains peroxide
1,4-Dioxane	C ₄ H ₆ O	Contains peroxide
Strong mineral or organic acids and bases		Corrosive to metallic components
THF	C ₄ H ₈ O	Contains peroxide

Further aspects to consider:

- Use HPLC- or p.a. grade solvents.
- Generally, solvents do not need to be degassed; only if the analytes of interest oxidize easily.
- Weak acids and bases, such as acetic acid or potassium hydroxide, or other non-corrosive additives may be used in small portions, i.e. <5 % by volume, added to the solvent system. Hydrolyzed food samples for fat determination can be used without any problems since the hydrolysed residue is washed to a neutral pH prior to extraction.

NOTE

Prior to an extended shutdown after an extraction flush the system (both INTO VIAL and INTO WASTE):

- with chlorinated organic solvents for 2 min with methanol
- with acidic or basic solvents with pure organic solvents such as ethanol or distilled water

See section 6.2.6 for a description of the flushing process.

Never use technical grade solvent. It is strongly recommended to use particle free solvents such as p.a. quality or HPLC grade solvent to guarantee proper operation of the valves, filters and frits.

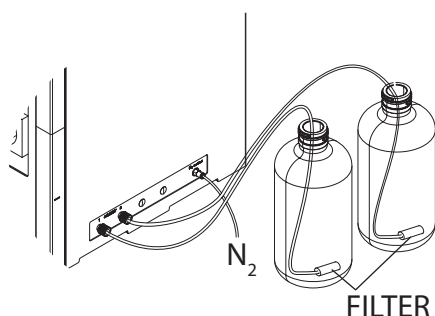

Filling the solvent reservoir:

To prevent air from being drawn through the lines, insert the inlet line (approx. 1 m) equipped with an intake filter (P/N 044340) into the reservoir until the filter touches the bottom.

6.2.2 Modifying the SOLVENT LIST

When creating an extraction method (see section 6.4.3) the solvent used for extraction needs to be determined. It is possible to create a list of up to 20 solvents for this purpose. The ten most frequently used solvents are programmed in the SOLVENT LIST by default. However, this list can be expanded or changed to include your own solvents or solvent mixtures.

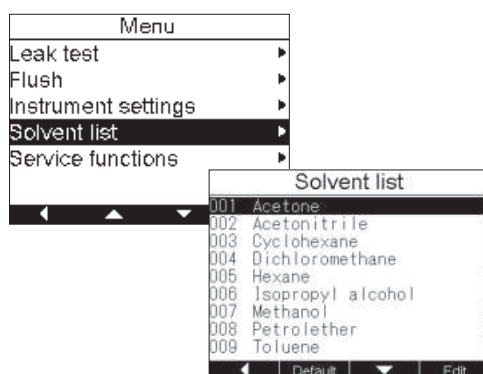

Open the list:

- Go to MENU → SOLVENT LIST to open the default solvent list consisting of 10 entries.

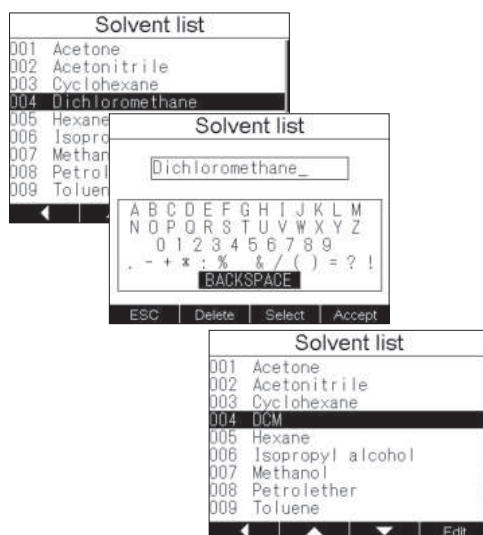

Changing an entry:

It is possible to change the default solvent list as needed. For example, to change DICHLOROMETHANE into DCM proceed as follows:

- Go to DICHLOROMETHANE and press EDIT. A submenu with different characters appears. To erase the whole name press DELETE. Move the cursor to D using the selection knob and press SELECT. Proceed similarly with C and M. To save the name press ACCEPT. The modified name now appears on the same position as previously Dichloromethane as DCM.
- To modify a name (e.g. Dichloromethane_1) open the EDIT menu, choose the corresponding characters and press SELECT. Confirm the changes with ACCEPT. The modified name now appears on the same position as previously Dichloromethane.

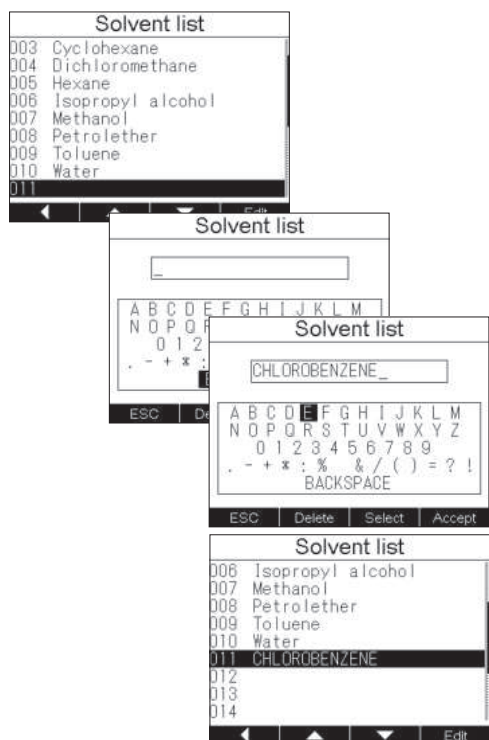

Adding a new solvent:

- To add new solvents to the list go to an empty position (e.g. no. 11) and press EDIT. The editing display is now empty. You can create your own names now using the selection knob. For example: An extraction is performed with chlorobenzene which does not belong to the standard list. Type CHLOROBENZENE as described above and press ACCEPT to add the name to the solvent list. Chlorobenzene now appears on position 011 on the solvent list.



Resetting the default list:

It is possible to reset the first 10 entries back to the default solvent list.

- Move the cursor to position 001. The move up function button is now replaced by DEFAULT. Press DEFAULT and confirm the message "Load default solvent list? First 10 entries replaced". The first 10 entries are now replaced by the default solvent list. The following entries (011 – 020) remain untouched.

6.2.3 Preheating the instrument

Preheating the instrument to the temperature of the subsequent extraction procedure is a mandatory operation as it equilibrates the instrument and hence prevents the cells and cup seals from damage.

	 CAUTION
	<p>Risk of burns by hot heating block and extraction cells.</p> <ul style="list-style-type: none"> Do not touch hot parts or surfaces Do not move the instrument or parts of it when hot

NOTE

Never preheat the instrument when the system is closed. Always equilibrate the instrument with vacant positions first.

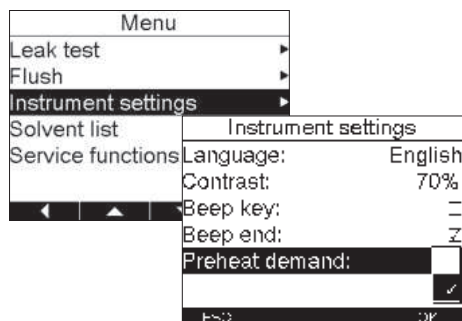
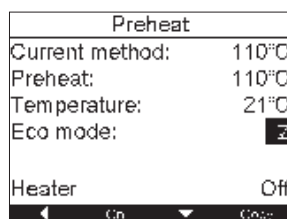
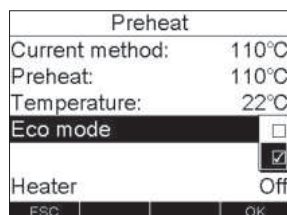
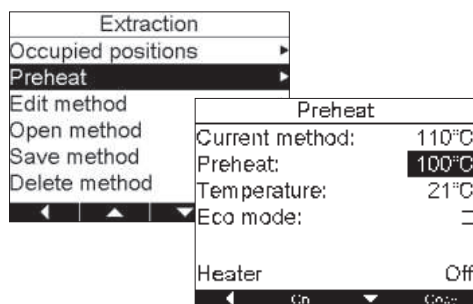
**NOTE**

When the temperature of a previous run is higher than actually required by the subsequent extraction method, long cooling off times are required. Placing empty and cold extraction cells into the heating block is a fast and effective measure to cool down a hot heating block to a lower temperature.

6.2.4 Activating/deactivating positions

Reducing the amount of solvent used for an extraction run is of vital interest. It is therefore possible to deactivate unused positions. The position valve of a deactivated position remains closed throughout the whole extraction process. Only the activated positions are flushed with solvent. It is important to note that an empty extraction cell has to be placed into a deactivated position. This is to achieve uniform temperature distribution throughout the whole heating block and to make sure that the lift is not at an incline when closed.

All extraction positions are deactivated by default. It is possible to activate all positions together or each individually.

Setting the preheat temperature:

- Go to EXTRACTION → PREHEAT to open the preheat submenu. CURRENT METHOD indicates the temperature setting of the current method. Use COPY to copy this value in the preheat entry to heat up the instrument to the temperature for the next run. Alternatively, set a new temperature using the selection knob.

Activating the ECO MODE:

The ECO MODE automatically turns off the heater after the next extraction run. It is recommended that the EcoMode be activated for unattended operation of an extraction run (e.g. starting a last run overnight).

- Use the selection knob to tick the ECO MODE. For more information see section 6.2.7.

Start heating:

- Press ON to start heating. The software goes back to the main display where the temperature slowly converges to the set temperature. To abort preheating go to EXTRACTION → PREHEAT and press OFF. The red STOP button on the control panel has no influence on the preheat function.

Preheat on demand:

Preheating the instrument is usually the first task when turning on the instrument. It is therefore possible to configure the instrument so that PREHEAT submenu appears as soon as the instrument is turned on.

- To activate this function open MENU → INSTRUMENT SETTINGS. Go to PREHEAT DEMAND and tick the function using the selection knob. Press OK to confirm.

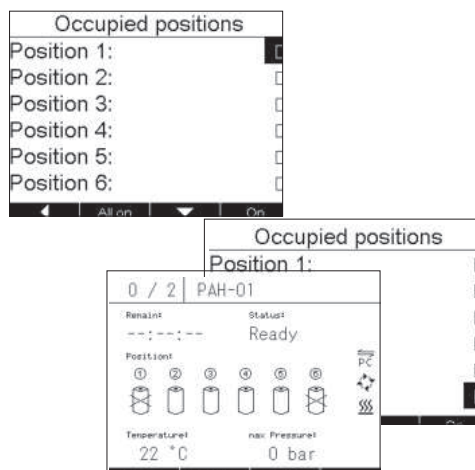
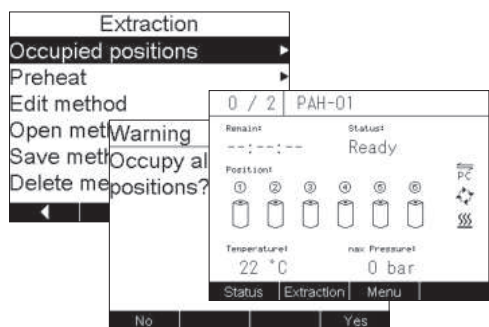
**NOTE**

Never run the instrument with empty positions. In order to achieve uniform conditions, always place identical empty extraction cells in the vacant positions. Therefore, using different sized extraction cells in the same run is not recommended.

Activate all positions together:

- Open EXTRACTION → OCCUPIED POSITIONS. Confirm “Occupy all positions?” with YES. The main display shows all activated positions as numbered cylinders.

Deactivate positions:

- To activate only the four middle positions, activate all positions first and then deactivate the positions 1 and 6. Go to EXTRACTION → OCCUPIED POSITIONS and this time negate with NO. All positions are deactivated now. Press ALL ON and move the cursor to the vacant positions (in the current example 1 and 6) and deactivate it by pressing OFF or using the selection knob. The main display now shows the vacant positions as crossed out cylinders.

6.2.5 Leak test

The LEAK TEST feature allows the operator to check quickly and safely whether the instrument is ready for operation. It is also a reliable measure to check the quality of the cup seals. A regular check before operation is therefore recommended, and is mandatory after a longer period of non-use and/or after replacement of the cup seals. There are two distinct approaches to perform a leak test. Firstly, very commonly the tightness of the system is checked using the very same parameters as for the subsequent extraction procedure. This allows the operator to evaluate the tightness on the basis of his own operating parameters.

Secondly, in a more absolute approach the leak test is always performed using the same reference settings. Thus, it is possible to reach conclusions on the basis of constant parameters. This is recommended in order to observe the long term behavior of the instrument, particularly of the seals or to ensure correspondence on a method-independent basis, relative to the same set of parameters. In contrast to a regular extraction method, to perform a leak test it is recommended to preheat the instrument with the extraction cells placed in the heating block for 15 min to avoid thermal fluctuations. Common to both approaches is the sample and instrument preparation:

- Preheat the instrument with the extraction cells placed in the heating block. It is not necessary to equip the cell with the plug screw (see section 6.2.3 and 6.4.1).
- Activate all positions (see section 6.2.4).
- Place empty collection vials into the collection rack and put it on the instrument as described in section 6.4.1.

Method-based leak test

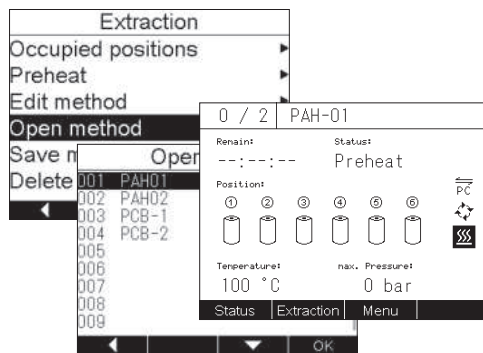

Open the method:

- Go to EXTRACTION → OPEN METHOD and select the requested method (e.g. PAH-01) and confirm with OK. The name of the selected method now appears in the main display.

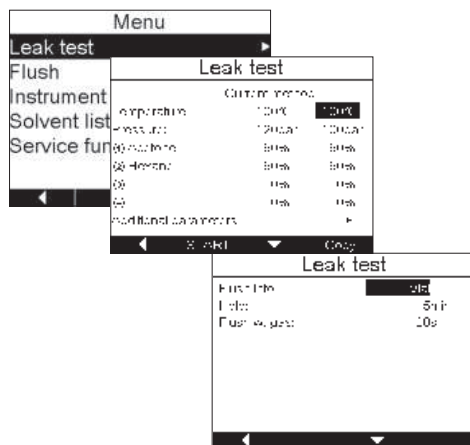

Copy the parameters into the leak test:

- Open MENU → LEAK TEST. The LEAK TEST menu consists of two columns. CURRENT METHOD includes all settings of the currently active extraction method (for instance PAH-01). SELECT shows the parameters of the last used leak test. To copy all parameters of the current method to the leak test press COPY. The cursor skips to the next entry. Proceed similarly for all entries.
- Under ADDITIONAL PARAMETERS the flushing conditions can be set, i.e. the receptacle to flush into, the hold time and the flushing time are defined.

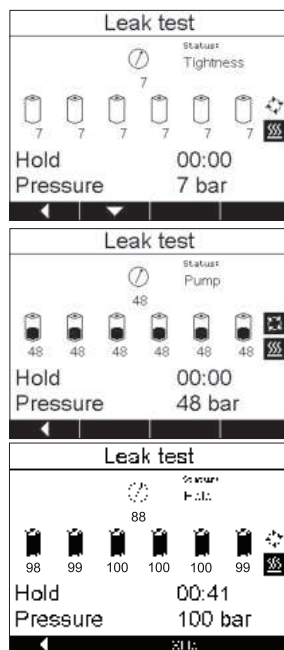

Start the leak test:

- Pressing START on the function buttons (not the green START button) closes the extraction cells and starts elevating the pressure by pumping solvent into the cells. A first TIGHTNESS test checks the presence of the extraction cells using nitrogen (see section 6.4.2). The pressure remains constant at 7 bar (pre-pressure) before it elevates the pressure to the set value (for example 100 bar) during the PUMP step. In the hold step the position valves and outlet valve are closed and the pressure is observed over a constant time (approx. 5 min). The pressure of each position as well as the overall pressure is shown below the extraction cell. In addition, the maximum pressure is designated by PRESSURE. The leak test is stopped after the set hold time is elapsed. Alternatively, the process can be stopped by pressing SKIP (not the red STOP button). The outlet valve opens, the solvent is discharged and the system is flushed with nitrogen. The measured pressure remains on the display. The evaluation of leak tests is described later in this section.

Standard leak test

The reference settings are used for the standardized leak test.

Reference setting for a standardized leak test

Description	Value
Temperature	100 °C
Pressure	100 bar
Solvent	ethanol
Hold time	4 min
Extraction cell	all volumes
Expansion element, sand	Expansion element 2–120 mL (refer to chapter 10) or sand

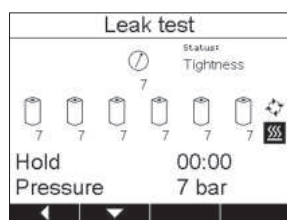
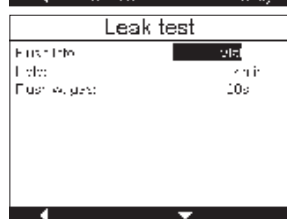
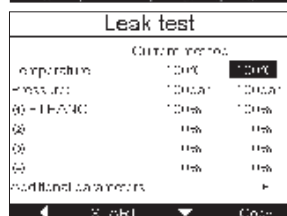
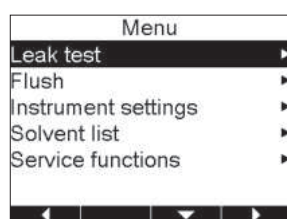

- Set the reference settings:
Open MENU → LEAK TEST. Instead of copying the entries of the CURRENT METHOD, set the reference settings according to the table above. For the TEMPERATURE, set 100 °C using the selection knob. Press OK. The cursor skips to the next entry. Proceed similarly to set 100 bar and 100 % ETHANOL.
Press START to run the leak test.

- As described for the method-based approach, the presence of the cells is first checked using nitrogen (7 bar) before the set pressure (100 bar) is reached.

Evaluation of leak tests

The absolute values depend on different parameters. These are: Set temperature and pressure, used solvent, cell size, and cell filling. When the following criteria are fulfilled, the instrument can be considered as tight and in good conditions:

- Maximum pressure difference between the positions does not exceed 15 bar.
- The pressure of the positions and the overall pressure has to be at least 95 % of the set pressure.
- The overall pressure should drop after reaching the set pressure while the individual position pressure(s) increases slowly. The overall pressure should not rise until the difference between overall pressure and position pressure(s) reached min. 25 bar. After this the overall pressure is allowed to rise and to follow the position pressure(s).

If the leak test shows that the SpeedExtractor is not tight, check the following options.

One or more positions have a lower pressure than the others:

- The drain valve is open → close the valve (see section 8.1.3)
- The cup seals (bottom or top) are not tight anymore. The seals can be used for at least 100 extractions, if not damaged mechanically by sand, sample, etc. → check visually, replace the faulty one (see section 7.2.2). If no damage can be seen due to a micro tear replace the bottom and top seal and repeat the leak test.

The overall pressure is too high:

- The position valve might be defective. It is recommended to verify this hypothesis by re-do a leak test, with only 2 positions activated. Choose therefor a position with the same or with a pressure close to the overall pressure, and a position with a significantly higher pressure. This second leak test helps to identify the faulty valve. → For exchange of a defective position valve, please contact BUCHI Service.
- The check valves of the pump are clogged due to impurities → clean the check valves (see section 8.1.5)

NOTE

Often a pressure increase of up to 10 bar or more is observed in the hold step. This is because the solvent and the cell are not heated up to the set temperature. In order to get good reproducible results, it is therefore advisable to perform a leak test twice.

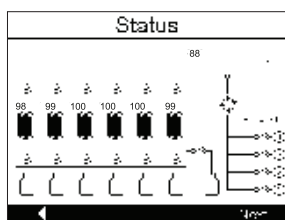

It is always possible to switch to the STATUS view during the leak test if the different stages of the process are of any interest.

6.2.6 Flushing the instrument

NOTE

When using analytes with low detection limits, the instrument must be flushed thoroughly for 2 min with a suitable organic solvent to avoid carryover before the next extraction run.

When changing the solvent from one run to another it is recommended that the lines be flushed with the solvent used for the subsequent extraction. You can either flush the solvent in the collection vials or the waste bottle. For the latter the lines from the outlet valve to the collection bottle are not flushed. However, placing the extraction cells in the heating block is always mandatory. Flushing with empty positions is impossible as the presence of the cells is checked during the flush procedure.

Parameters	E-916	E-914
Flush with solvent	120 s	180 s
Flow rate	50mL/min	50mL/min
Flush with gas	180 s	240 s

NOTE

Always use empty extraction cells to flush the system. Changing the solvent while the extraction cell is filled, can result in extraction and hence contamination of the lines with matrix constituents.

In contrast to flushing during extraction (see section 6.4.2), the flow rate is not reduced in the FLUSH

mode when positions are deactivated. This allows a fast and efficient flushing when using a reduced number of positions.

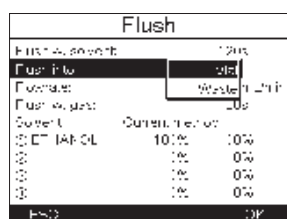
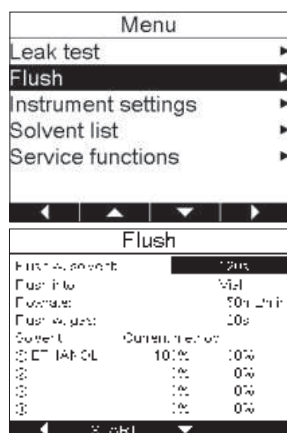

NOTE

When changing the solvent reservoirs (e.g. from hexane to ethanol), take out the filter and rinse it thoroughly with the new solvent to prevent contamination with the old solvent.

Flush into waste:

- Open MENU → FLUSH. Set the time to flush with solvent. FLUSH INTO makes it possible to choose between waste or vial. Choose WASTE using the selection knob. Set the flow rate and flush with gas according to the recommended parameter in the table above. The CURRENT row in the SOLVENT section shows the settings of the currently active method. Press COPY to use these entries or set new values using the selection knob. Press START on the function button.

NOTE

The green START and red STOP button do not have any influence on the flush process. To stop the process open the flush submenu again and press STOP.

Flush into vial:

- Open MENU → FLUSH and choose VIAL for the FLUSH INTO entry using the selection knob. Set all other parameters as described above and shown in the reference settings table.

6.2.7 Activating the EcoMode

In the normal operating mode the instrument is ready for operation and therefore keeps the temperature constant at the level set in the PREHEAT menu. It is however possible to activate the EcoMode which automatically turns off the heater once the current extraction is finished. It is recommended that this mode be used for unattended last extraction runs such as overnight runs. By turning the instrument off and on, the EcoMode is automatically deactivated.

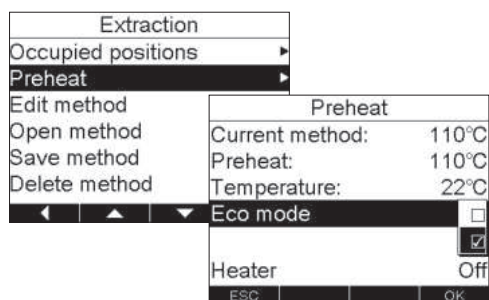

Activating the EcoMode:

- Open EXTRACTION → PREHEAT. Move down to ECOMODE with the corresponding function button and activate it using the selection knob. There is no need to confirm with ON. By simply ticking it the ECOMODE is already activated.

6.3 Preparing the sample

The following sections describe all operations being involved to prepare the sample for the actual extraction process.

6.3.1 Sample preparation

To maximize extraction efficiency, samples that are coarse, lumpy or rocky must first be ground and/or sieved to achieve a uniform particle size. Conversely, fine mesh samples may form tightly compressed beds which restrict solvent penetration and impede solvent discharge. Such samples must be mixed with a drying (diatomaceous earth) or dispersing (sand) agent before loading the extraction cell. If a successful sample pretreatment procedure from another extraction method is known, also follow this particular procedure for the SpeedExtractor. However, for new samples the following guidelines may be helpful:

- Dry samples work best, because water often tends to co-extract. Wet samples must be air or oven dried before extraction. Wet samples reduce extraction efficiency and may cause blowback due to restricted flow through the sample bed. To dry and/or disperse samples, blend them with diatomaceous earth (DE) (P/N 053201) or extraction sand (P/N 037689) in order to decrease sample density, achieve uniform flow and increase analyte recovery. Generally, diatomaceous earth dries samples more quickly than sodium sulfate and hence provides a cleaner transfer of the mixture to the cell. On the other hand, sodium sulfate tends to clump the sample, making transfer more difficult.
- The use of sodium sulfate with very wet samples (i.e. moisture content approx. 30 %) may result in recrystallization of sodium sulfate and hence clogging of the metal frit in the extraction cell. This is the case particularly with solvent mixtures with acetone. In these cases blending the samples with DE before loading into the extraction cell is highly recommended.
- Never use sodium sulfate with polar extraction solvents such as methanol, because this drying agent is partly dissolved at the temperatures typically used for SpeedExtraction methods.
- For samples which are easily extracted particle sizes of 1 – 2 mm provide generally good results. For more critical samples particle sizes 500 µm are recommended.
- The material of the bottom filter (which is placed between the metal frit and the sample) may influence the speed and efficiency of the discharge and flushing step significantly. The standard glass fiber filter is suitable for all applications. For samples with easy discharge and flush, the cellulose filters (P/N 049569) can be an alternative.

NOTE

Consider the SpeedExtractor Application Booklet for general information about preparation of different types of samples. It also includes application notes with reference settings for the most frequently used application particularly in the environmental and food market. Sample types such as polymers may soften or dissolve in solvent media such as dichloromethane and subsequently extrude through the fluid transfer lines resulting in plugged tubing and valves. Therefore it is recommended to use extraction thimbles. Additionally, some analytes are prone to precipitate after being cooled down rapidly by passing the cooling unit. For critical samples it is therefore recommended to use a smaller cooling unit instead (P/N 053682). Exchange of the cooling unit, however, requires an authorized service technician. Please contact BUCHI or your local dealer.

6.3.2 Extraction cell selection

NOTE

The process parameters are optimized to each type of extraction cell. Therefore, never mix extraction

cells of different sizes in the same run. Different cell sizes in the same run result in inhomogeneous heat transfer.

There are various extraction cell sizes available, depending on the number of positions (see adjacent table). The size of the extraction cell does not necessarily affect the extraction time during the HOLD stage, but it does determine the time used to reach equilibrium (HEAT-UP stage; see section 6.4.2), as well as the amount of solvent used for the method. As the cell is filled with solvent during an extraction process, larger cells, or only partially filled cells require more solvent. However, the same method might require slight modifications if performed with different sizes of extraction cells. To optimize the amount of solvent, follow these guidelines:

Extraction cell sizes	
SpeedExtractor E-916	
• 10 mL	P/N 051237
• 20 mL	P/N 051236
• 40 mL	P/N 051235
SpeedExtractor E-916XL	
• 60 mL	P/N 11069535
SpeedExtractor E-914	
• 10 mL	P/N 11067988*
• 20 mL	P/N 11067989*
• 40 mL	P/N 051234
• 80 mL	P/N 051233
• 120 mL	P/N 051232

*Only Firmware Version 1.05 or higher

- Select the smallest cell that holds enough sample to produce accurate results.
- Take into account the volume increase resulting from drying or dispersing agents.
- For very small samples an expansion element may be used to fill up the void volume of partially filled extraction cells (P/N 053708).

NOTE

This expansion element fits only 10 mL extraction cells. The height of this cylindrical body is 2 cm. Hence, one or two displacer can be used to fill up the remaining space, depending on the sample volume.

6.3.3 Packing of the cells

① Insertion of the lower filter, metal frit and threaded plug screw

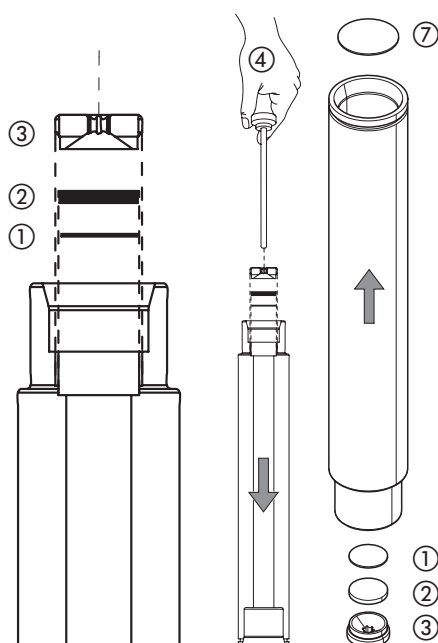

Put the extraction cell upside down (with the serial number at the bottom) on a bench top and insert first a filter ① of disposable glass fiber (P/N 11055932) or cellulose (P/N 049569) using tweezers. Place the filter on the offset of the cell and make sure that it is in full contact with the cell. The filter prevents blockage of the metal frit and is therefore mandatory to use. The glass fiber filters are suitable for all application. They are required for fatty, fine powdery samples, for aqueous extractions and samples with remaining moisture, in order to ensure an adequate filtration. They are also recommended for trace and ultra-trace analysis, as their use results in lower blank values. For other samples and solvents, the paper filter might be sufficient too. Place the metal frit ② (P/N 049568) onto the filter and close the bottom of the cell with the plug screw ③ (P/N 053209) using the plug screw tool ④ (P/N 053607). Make sure that the concave surface of the plug screw points to the cell.

Alternatively, use a paper or glass fiber thimble to fill in your sample. The thimbles are recommended for polymers and plastics (samples with tendency to melt during the extraction process) and sticky samples, when not mixed with sand or diatomaceous earth. They are specially recommended for the method development of the mentioned sample types. Glass fiber thimbles are beneficial for gravimetric and residue determinations (lower blank value than paper thimbles).

NOTE

Close the plug screws hand tight. Over tightening the plugs can damage the cell. They are not used to seal the cell but only to fix the filter and frit in place.

② Insertion of the sample

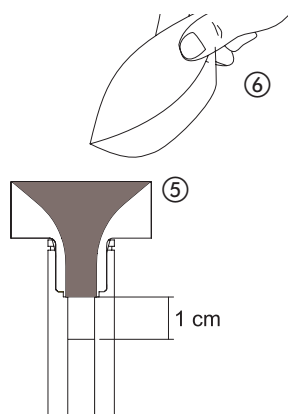

Turn back the cell to its “regular” orientation (the frit is now at the bottom) and insert the metal funnel (5) into the offset of the cell (or the graduated line for the largest cells; 40 mL for the E-916, 60 mL for E-916XL and 120 mL for the E-914). It is recommended to place the cells into the cell rack for sample loading (E-916: P/N 053690; E-916XL: P/N 11069547; E-914: P/N 053691) to provide more stability.

In order to carefully load the sample into the cell using the optional weighing boat (6) (P/N 053202). Rinse the weighing boat with some additional sand. If desired, fill any cell void volume with additional sand or, in the case of the 10 mL cells, use the optional expansion element, 2 mL (P/N 053355) to reduce the amount of solvent for extraction.

Alternatively, use a paper or glass fiber thimble to load your sample. The use of thimbles is recommended for polymer samples and plastics with tendency to melt during the extraction process and sticky samples, when not mixed with sand or diatomaceous earth. In particular they are recommended for method development in case of complex sample types. Glass fiber thimbles are beneficial for gravimetric and residue determinations with impact on lower blank value than paper thimbles.

NOTE

It is important not to fill the cell completely but to retain a void approx. 0.5 – 1 cm in height between the sample bed and the upper filter. This prevents the sample from clogging in case of swelling and thereby guarantees uniform flow.

Differently packed extraction cells usually require different amounts of solvent, because the dead volume and back pressure are different.

3 Keep the sealing surfaces clean

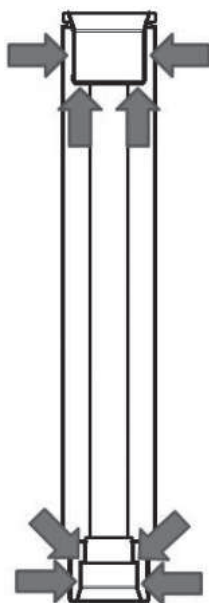

4 Insertion of the upper filter

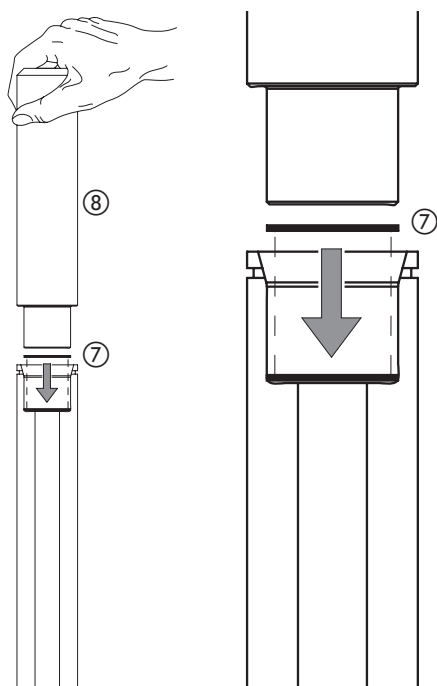

Insert the upper cellulose ⑦ (P/N 049572 for E-916, P/N 11069533 for E-916XL, P/N 051249 for E-914) or glass fiber filter (P/N 11057189 for E-916, P/N 11057190 for E-914) carefully uniformly into the cell using the plunger ⑧. The top glass fiber filters are recommended for trace and ultra-trace analysis. Again, visually inspect the cell for remaining grains above the filter and make sure that the filter is in full lateral contact with the cell.

NOTE

Do not attach any labels to the cell! The dimensions of this assembly have been optimized to provide optimal and uniform heat transfer from the heating block to the extraction cell. Additionally, the high temperatures might damage the label. For unambiguous sample identification, every single extraction cell is etched with a serial number.

Filters and frits

Filters and metal frits

• Bottom filter, cellulose (qty 100)	049569
• Bottom filter, glass fibre (qty 100)	11055932
• Top filter E-916, cellulose (qty 100)	049572
• Top filter E-916XL, cellulose (qty 100)	11069533
• Top filter E-914, cellulose (qty 100)	051249
• Top filter E-914, glass fiber (qty 100)	11057190
• Top filter E-916, glass fiber (qty 100)	11057189
• Metal frit (qty 25)	049568

Extraction thimbles

• Thimble 40 mL cell, cellulose (qty 25)	11055334
• Thimble 40 mL cell, glass fiber (qty 25)	11056633
• Thimble 80 mL cell, cellulose (qty 25)	11059610
• Thimble 80 mL cell, glass fiber (qty 25)	11059612
• Thimble 120 mL cell, cellulose (qty 25)	11055358
• Thimble 120 mL cell, glass fiber (qty 25)	11059611

Metal funnels

• E-916, 10 mL cell	053035
• E-916, 20 mL cell	053396
• E-916, 40 mL cell	053397
• E-916XL, 60 mL cell	11069529
• E-914, 10 mL, 20 mL cells	11067712
• E-914, 40 - 120 mL cell	053036

NOTE

Be sure to clean the sealing surfaces at the top and the bottom carefully, i.e. the offset and the surfaces above it. Use the brushes for that purpose. Any remaining sample or grain of sand reduces the lifetime of the cup seals and the extraction cells significantly. In case of proper operation the seals last for 100 extraction runs.

6.4 Extraction process

Each extraction procedure occurs according to a set of predefined operating parameters such as pressure, temperature, flow rates etc. which are all part of the extraction method. The SpeedExtractor can store up to 100 methods. The optional PC software SpeedExtractor Record allows to create and manage an unlimited number of methods.

In order to guarantee reproducible conditions, it is recommended to make the instrument ready for the extraction process as described in section 6.2, to prepare the samples in the meantime (section 6.2) and start the extraction method as soon as the cells are placed in the heating element.

The following sections describe the individual stages of an extraction process, how to create, store and open methods and how to optimize existing procedures.

6.4.1 Placing the cells and bottles/vials into the instrument

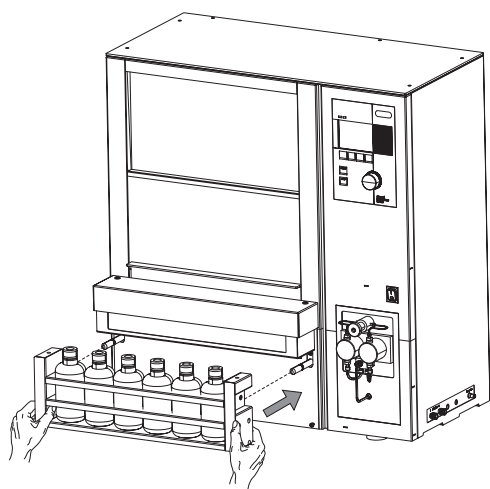

Fill the collection tray with empty vials and push it to holding fixture.

The tray will automatically move upwards as the extraction process starts. If 60 mL vials are used (P/N 049535) fix the vials with the optional retaining plate P/N 11055205 (see also section 10).

If Syncore Analyst R-12 / R-6 vessels are used fix the vessels with the optional retaining plate P/N 11057054 for E-916 / R-12 and P/N 11058339 for E-914 / R-6 (see section 10 for all available collection units and accessories).

NOTE

The collection tray must be placed properly on the instrument to start a method. It is not possible to start a run in the absence of the tray.

Make sure to always fill the collection tray with empty collection vials.

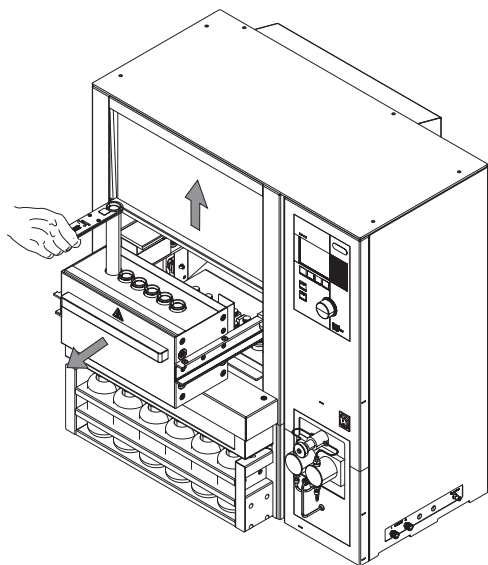

The heating block is fixed on movable guide rails. This allows the operator to push the heating block to the back to get easy access to the cup seals (for inspection or exchange) and to pull it out to load the extraction cells. Proceed as follows: Push the protective shield to the top and pull out the heating block as far as possible. Use the extraction cell gripper (P/N 053030 for E-916, P/N 11069534 for E-916XL, P/N 053026 for E-914) to place the cells into the heating block. Move the heating block backward until it snaps in the middle position. Close the protective shield for safety reasons. The lift does not move unless the shield is closed.

NOTE

In order to achieve reproducible results, never place the extraction cells in the heating block before the operating temperature is reached (equilibrium).

6.4.2 Stages of an extraction cycle

Generally, every extraction method consists of a number of cycles, which can be divided into 3 phases, the heat-up, hold and discharge time. Prior the first cycle, the tightness test is carried out.

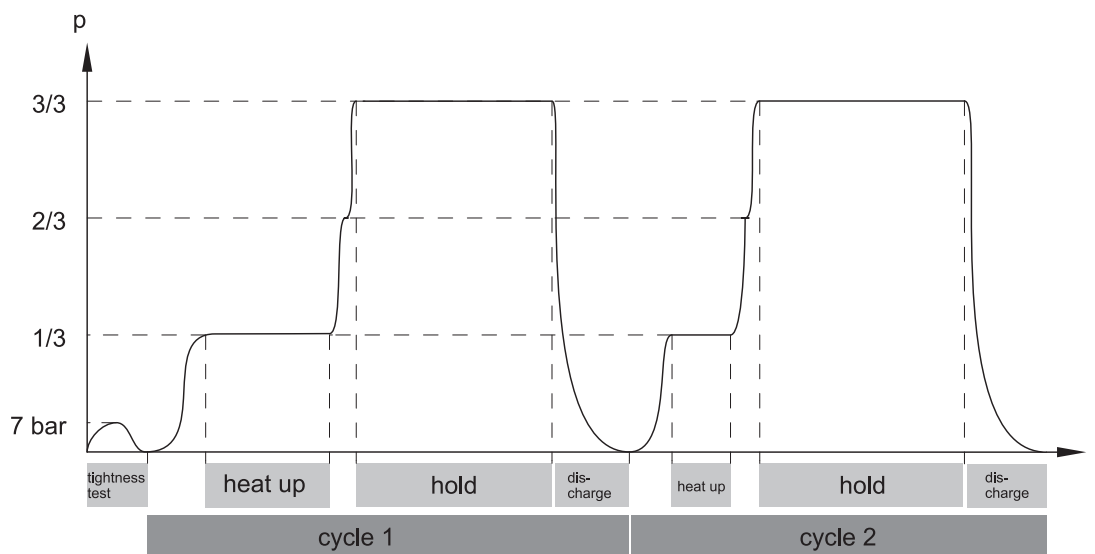

- Tightness test using nitrogen (checks, whether there is a cell in the activated position)
The tightness test is a quick initial check that verifies whether the system is closed. In the event of open outlet valves or empty positions in the heating block, the extraction run is aborted, and error message is displayed.
The tightness test is not the same as the leak test (section 6.2.5). The leak test scrutinizes the leaking rate of each position and displays the corresponding pressures accordingly; it is not part of the extraction method. On the other hand, the tightness test is an inherent element of each extraction procedure and cannot be altered or modified in any way. It is essentially an internal safety procedure and is therefore not accessible to the operator.
- Heat-up time (heat-up of sample, solvent and cell)
In the time period between the tightness test and hold step the pressure is increased step-by-step

to 1/3 and 2/3 of the final pressure. The HEAT UP time is defined as the time during which the pressure remains at 1/3 of the total pressure. A further prerequisite is that the temperature of the heating block reached its equilibrium. It is a method-dependent intrinsic parameter which depends mostly on the size of the extraction cell and is therefore not adjustable by the operator.

- Hold time
The hold time corresponds to the static extraction time during which the temperature and pressure remains constant. This time period is only determined by the nature of the sample and hence set by the operator.
- Discharge time
Time used to discharge the extraction cells by means of pressure compensation. Make sure the time is long enough to empty the cell completely.

Close consideration of the process shown above reveals that there are two variable time periods between the tightness test and the heat up and the heat up and the hold step, respectively. These periods depend on the process parameters, the sample's property and packing in the cell, and the size of the extraction cell. The accurate values are therefore only available in hindsight. The remaining time used to finish process which is shown in the main and the progress display, is based on rough estimations for these periods. Slight changes, observable by leaps in time, are therefore possible.

- Next cycle or Flushing the system
After the last extraction cycle is finished and the extract is discharged, the lines are flushed with solvent first, followed by nitrogen to thoroughly empty the lines. Make sure that the flush with solvent and gas are long enough to avoid carryover due to analyte residues of the last cycle (flush with solvent) and to avoid a blow back of the sample due to solvent residues (flush with gas).

6.4.3 Creating new methods

A summarized overview of all extraction parameters as well as recommended default values are given in section 6.4.4.

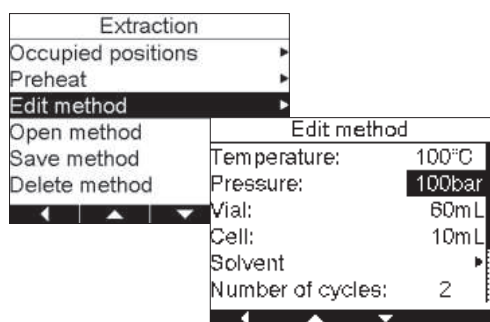

Open the submenu EDIT METHOD:

- To create a new method open EDIT METHOD in the EXTRACTION menu. Use the selection knob to set the values for the temperature and pressure according to your procedure.

As a rule of thumb it is recommended to set the temperature approximately 20 – 30 °C over the boiling point and the pressure to 100 bar.

Edit method	
Temperature:	60mL
Pressure:	150mL
Vial:	220mL
Cell:	240mL
Solvent	Waste
Number of cycl	Unspecified

Specify the vial volume:

- Specification of the volume of the collection bottle is an important safety feature, since it alerts the operator if there is a conflict with the total volume used for the subsequently defined extraction volume. The volumes of the most frequently used bottles (60 mL, 150 mL, 220 mL and 240 mL) are predefined. If using other volumes than the mentioned ones, select "unspecified". It is also possible to extract into the waste. This option is made for applications where the sample after extraction is of interest, not the extract. Change the parameter using the selection knob.

Edit method	
Temperature:	100°C
Pressure:	100bar
Vial:	60mL
Cell:	10mL
Solvent	20mL
Number of cycles:	40mL

Specify the cell volume:

- Specifying the volume of the extraction cell is mandatory, because it has an influence on some process-related parameters, such as the heat-up time. Change the parameter using the selection knob.

NOTE

If the total extract volume gets too large and/or the extract of different cycles are to collect separately, insert a vial change in the method to exchange the collection bottle between runs (see next paragraph).

Define the solvent mixture

- Go to the SOLVENT submenu to choose a solvent or solvent mixture according to the solvent list previously adapted (see section 6.2.2) by either pressing LIST or directly using the selection knob. Press SELECT to select the solvent for your solvent reservoirs and set the solvent ratio according to your method. Proceed similarly with other solvents if necessary. The NEXT button moves the cursor forward to the next entry.

Edit method	
Vial:	60mL
Cell:	10mL
Solvent	▶
Number of cycles:	
Cycles	
Flush w. solvent:	

Solvent	
Type:	Ratio:
① Methanol	90%
② Water	10%
③	0%
④	0%

NOTE

The sum of the ratios must be equal to 100 %.

If alternating solvents per cycle are used, choose 100% only for one solvent reservoir as the sum has to equal 100 %.

- The EDIT button allows you to directly modify the solvent name without changing the solvent list. Press ACCEPT to confirm the changes and switch back to the EDIT METHOD display with the left arrow.

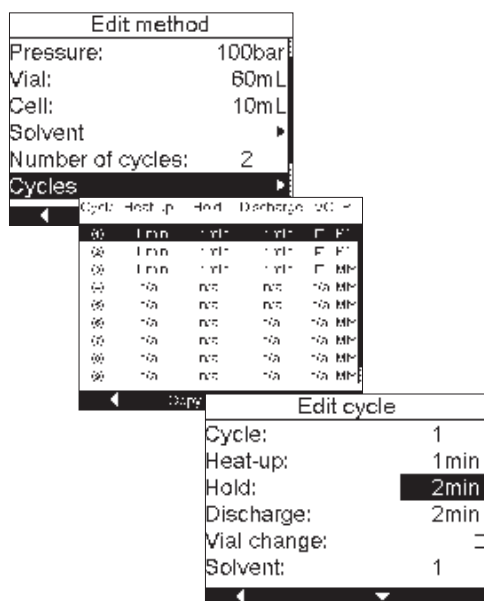

Define the cycles:

- Specify the number of cycles and go to the CYCLES submenu. The CYCLES submenu contains all cycles including their operating parameters such as HEAT-UP, HOLD and DISCHARGE time. There are only as many cycles shown as defined in NUMBER OF CYCLES. All other entries are not applicable (n/a).
- To change parameters of a given cycle, move the cursor to the corresponding cycle and press EDIT. The new sub-submenu shows the number of the cycle, the HEAT-UP time, which cannot be altered, the HOLD time and the DISCHARGE time. Change the entries using the selection knob. Move to the next entry using the down arrow. Activate VIAL CHANGE to exchange the collection vials between the cycles to separately collect extracts of different cycles or when the total volume of the extract exceed the vial volume. In this case the warning "Vial overflow possible. Please validate vial size and cycles." appears. Confirm with YES and change the parameters or include a vial change. But keep in mind that this extends the total extraction time.
- Select the solvent for each cycle by using the selection knob. Solvent 1 – 4 correspond to the solvent reservoir ports 1 – 4. Solvent 0 has to be selected, if the extraction is done with a solvent mixture, see section "Define the solvent mixture". This option allows to change the solvent from one cycle to the other.

Flush with solvent/gas

- The time of the flush with solvent and flush with gas can be entered by turning the selection knob. It is mandatory to flush the system with gas for at least 1 min (E-916) or 2 min (E-914) respectively.

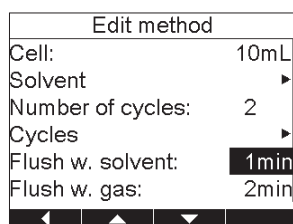

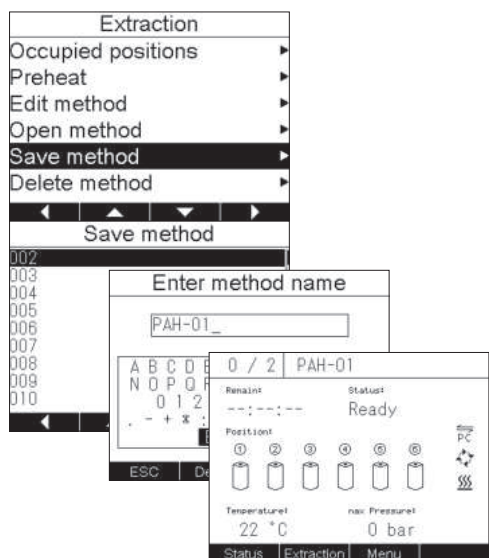

Save the method:

- In order to save the modified new method, go to SAVE METHOD back in the EXTRACTION menu, select an empty position, and press OK. Alternatively, choose an already occupied position to overwrite it. Modify the name in the ENTER METHOD NAME window or write a new one by pressing DELETE. To type a name, choose the corresponding characters and press SELECT. Confirm the changes with ACCEPT. The title of the new, currently active method is now shown in the header of the main display. Up to 100 methods can be saved in total.

NOTE

Changes on a currently active method are indicated by a crossed out title in the main display.

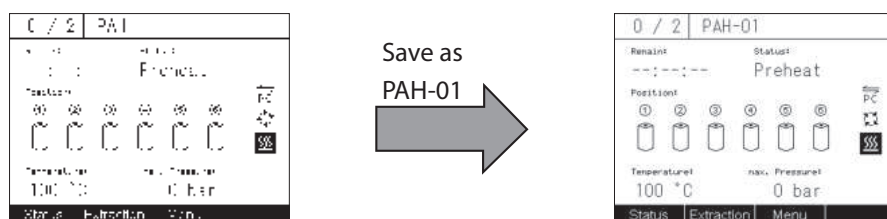

6.4.4 Summary of operating parameters

The following table summarizes the operating parameters required for an extraction method, their function, and value range. Additional recommendations can be found in the corresponding Application booklet.

Operation parameters		
Parameter	Function	Value range
TEMPERATURE	Defined set temperature used for the HOLD time. This value also influences the time used for the HEAT-UP.	30 – 200 °C (default 100 °C)
PRESSURE	Pressure inside the extraction cell during the HOLD time.	50 – 150 bar (default 100 bar)
VIAL	Size of the collection bottle. There are different vials available from BUCHI: flat bottom narrow neck vials (60, 240 mL) / round bottom open neck vials (220 mL) / Analyst vials (150 mL) / unspecified vials (e.g. for the use of round bottom flasks in combination with the Rotavapor collection unit) and waste	60, 150, 220, 240 mL, unspecified, waste (default: 240 mL)
CELL	Size of the extraction cell. The options depend on the instrument configuration. It partially determines the HEAT-UP time.	E-916: 10, 20, 40 mL E-916XL: 60 mL E-914: 10, 20, 40, 80, 120 mL
SOLVENT	Solvent mixture with which the extraction is performed. The type of solvents connected to the solvent reservoir ports on the right side of the instrument and their ratios are determined in a submenu.	list of 20 solvents (default: 10 solvents)

Operation parameters		
Parameter	Function	Value range
TYPE	Type of solvent in solvent reservoir 1 – 2 or 1 – 4 depending on the instrument configuration.	list of 20 solvents (default: 10 solvents)
RATIO	Percentage of solvent 1 – 2 or 1 – 4 used to create the extraction method. The sum is always 100 %.	1 – 100 % sum: 100 %
NUMBER OF CYCLES	How many times the HEAT-UP, HOLD, and DISCHARGE steps are performed.	1 – 10 (default: 1)
CYCLES	Involves all parameters relevant for an extraction cycle. They are accessible in a submenu.	
HEAT-UP	Time used for the HEAT-UP step. Parameters such as temperature and size of the extraction cell determine the HEAT-UP time.	fixed
HOLD	Time used for the extraction at constant temperature.	0 – 60 min (default: 2 min)
DISCHARGE	Time used to empty the extraction cells. This step is not supported by nitrogen gas. Purging with nitrogen is achieved with the FLUSH WITH GAS parameter, which is not part of the extraction cycles but follows the last cycle.	0 – 60 min (default: 2 min)
VC	Vial change. Option which makes it possible to change the collection vials between the cycles. The solvent used in the last cycle is also used for the flush.	<input type="checkbox"/> , <input checked="" type="checkbox"/> (default: <input type="checkbox"/>)
P	Solvent selection of the used solvent port for each cycle.	1 – 2, resp. 1 – 4 (depending on configuration), 0 = solvent mixture (default: 0)
FLUSH WITH SOLVENT	Time flushing with solvent. For the extraction method the flow rate is adjusted automatically. The solvent used in the last cycle is also used for the flush.	0 – 9 min (default: 1 min)
FLUSH WITH GAS	Time flushing with nitrogen.	1, 2 – 30 min (default: 3 min)

6.4.5 Example of an extraction method

Example: Extraction of 6x5 g sample in 10 mL extraction cells with acetone 50 % and DCM 50 %, 3x5 min at 80 °C and 100 bar.

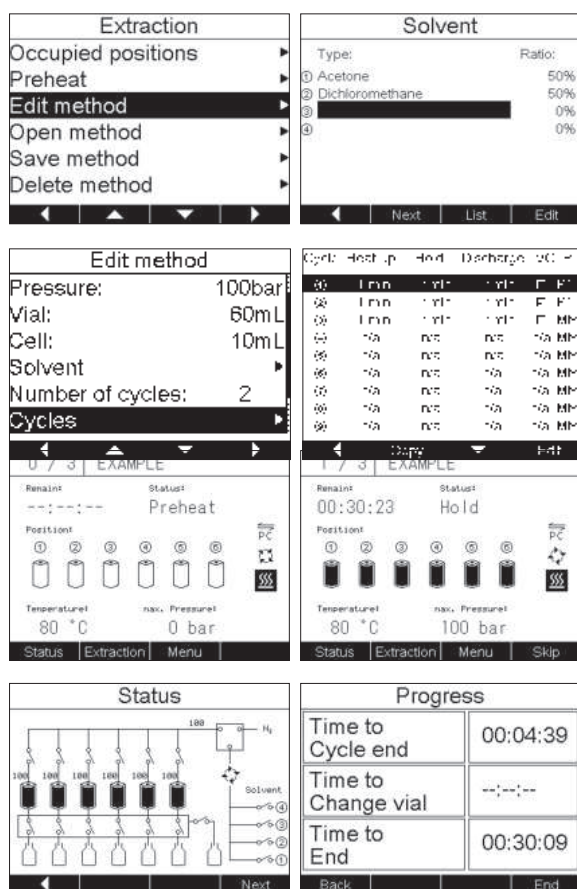

Procedure:

- Connect the solvent reservoirs to the corresponding ports: ①: acetone, ②: DCM
- Activate the extraction positions: EXTRACTION → OCCUPIED POSITIONS → YES.
- Flush with solvent (optional): Insert empty extraction cells in all positions. MENU → FLUSH → FLUSH INTO WASTE: Flush with solvent: 120 s; flow rate 50 mL/min; flush with gas: 180 s; solvent: ①: acetone 50 %; ②: dichloromethane 50 %. Remove the extraction cells.
- Preheat: EXTRACTION → PREHEAT: 80 °C, OK, ON. The oven starts heating.
- Create method: EXTRACTION → EDIT METHOD: Temperature 80 °C; pressure 100 bar; vial 60 mL; cell 10 mL; solvent (see optional FLUSH); number of cycles 3; cycles: hold 3 min, discharge 2 min, no vial change (conditions apply for all 3 cycles); flush with solvent 2 min; flush with gas 3 min.
- When the set temperature is reached, insert samples and collection vials (60 mL) and close the protective shield.
- START

6.4.6 Open an existing method

To open an existing method, proceed as follows:

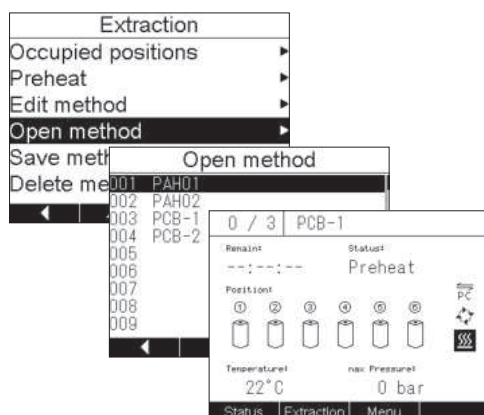

- Select OPEN METHOD in the EXTRACTION menu. All saved methods (up to 100) are stored in a numbered table. Select the desired method and press OK. The name of the method now appears in the title of the main display.

6.4.7 Optimize a process

The following guidelines may help to optimize an extraction process in terms of yield and time.

Guidelines to optimize an extraction process		
Action	Advantage	Drawback
<p>Raising of the temperature In general, raising the temperature increases the yield of the extraction process. However, particularly for temperature sensitive compounds, it is advisable to keep this parameter rather low to prevent degradation. Generally, temperatures of 20–30°C above the boiling point provide good results. If oxidation is a concern, degas the solvents prior to use, and close the solvent reservoir.</p>	increased extraction efficiency	possible degradation and/or oxidation
<p>Multiple extraction cycles Extending the hold time (see section 6.2.4) enhances diffusion of the analyte into the extraction solvent to a certain extent. However, using fresh solvent by introducing a new cycle helps maintain a favorable solvent/analyte equilibrium, particularly for samples that are heavily loaded.</p>	increased extraction efficiency	longer total extraction times
<p>High pressures for wet samples For wet samples, higher pressures often provide better results in terms of yield and extraction efficiency. This is mostly due to better matrix penetration of the solvent and hence faster diffusion of the analyte from the matrix into the solvent.</p>	increased extraction efficiency	possible clogging of the sample as the sample is high in moisture
<p>Short extraction time (hold) for first cycle Particularly for saturated samples, a quick first cycle is an effective measure to prevent precipitation of the sample on the way to the collection vials.</p>	no precipitation in the lines	possible additional extraction cycle required
<p>Short discharge and flush times For optimization purposes it is advisable to use long discharge times (i.e. 3 min for E-916; 7 min for E-914) and to determine the time needed until no more drops are collected in the vial and to let the pressure drop to 0-1 bar. A shorter discharge time can then be stored in the final method. A similar approach is recommended for the flush with gas time. To speed up the flush with gas, a SKIP button appears after a defined minimal safety period, to move onto the final stage, given that the pressure is 0-1 bar.</p>	Shorter extraction times	none

For more detailed information about method development and optimization, please consider BUCHI's SpeedExtractor Application booklet and BUCHI's Application and Technical Notes. Please contact your sales person or BUCHI for these documents.

6.4.8 Start, pause, stop and abort extraction

Use the green START and the red STOP buttons to start, pause, abort, or interrupt an extraction process. These buttons are only applicable to the extraction process. All other procedures such as flush or preheat are controlled by the function buttons (see also section 4.5.1).

- **Start:** Go to the main display and press START once. The START button is only active in the main display.
- **Pause:** Press STOP once. The process is interrupted and can be continued by pressing START again. Recommended action, e.g. the solvent reservoir is going to run dry or not connected.
- **Abort:** Press STOP twice. The process is aborted, the extraction cells are discharged and flushed with nitrogen, and the collection rack and heating block are returned to their starting position. Recommended action, e.g. if it turns out that the selected extraction method does not work properly.
- **Abort immediately:** Press STOP three times: The process is interrupted, and all assemblies remain at their operating positions. All actions such as releasing the lift or opening the position valves, can be controlled manually using the service menu. Recommended action in case of an unexpected occurrence.

6.4.9 Post-extraction procedures

	<p>! CAUTION</p>
<p>Risk of dangerous or moderate burns when handling hot extraction cells.</p> <ul style="list-style-type: none"> • Do not touch any hot parts • Always use the gripper to move extraction cells 	

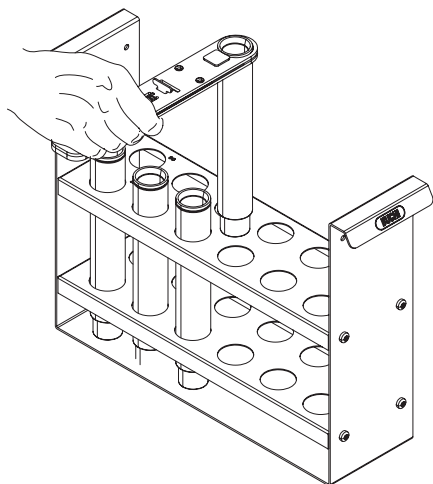

Cleaning the extraction cells

- After the extraction process is finished, open the protective shield, pull out the heating block, and take out the extraction cells using the extraction cell gripper. It is recommended that the hot extraction cells be placed into the rack (E-916: P/N 053690; E-916XL: P/N 11069547; E-914: P/N 053691) to cool down the cells.
- Remove the upper filter using the filter hook (P/N 053316). Turn the cells upside down to get rid of the sample mixture. Unscrew the plug screw. Remove the sample using the extruder rod P/N 11055284. Dispose of the filter, and clean the metal frit and the plug screw in an ultrasound bath. Rinse the extraction cells with water or organic solvent, put them for example in acetone (or a methanol/acetone/hexane mixture) for 5 – 15 min, and then put them in a dishwasher or oven. Do not exceed 300 °C for the latter.

Cleaning the seals

- If necessary, rinse the seals with organic solvent (e.g. ethanol) with the help of beaker. Always visually inspect the seals for dust, sand or scratches.

NOTE

Never clean the cup seals with a wet towel or wipe. Any kind of residue might cause a leak and/or reduce the lifetime of the cup seals.

Cleaning the upper cup seal frit

- In case of unexpected contamination, remove the top cover plate (position 4 on page 95) and clean it in an ultrasound bath.

Flushing the lines

- If the next extraction method involves a different type of solvent, flush the lines thoroughly with the new solvent as described in section 6.2.5.

For further periodic maintenance procedures see section 7.2.

6.5 Creating a report (optional)

Optional PC software is available (P/N 053073), which allows communication between the SpeedExtractor and a PC via a USB port. The SpeedExtractor Record software allows you to fully create, edit, and store extraction methods. It also includes a real-time status view of the SpeedExtractor. Moreover, a visualization window graphically represents the temperature pressure sequence during extractions and leak tests. All unexpected events like pause or vial change will be recorded. The logbook contains all relevant maintenance information about e.g. number of extractions or leak test information. Finally, the process report feature generates full documentation, including all process parameters and information, as well as the temperature/pressure profiles, in PDF or CVS format. For more information regarding the SpeedExtractor Record software, please refer to the corresponding manual on the free trial CD (valid for 60 days) which is part of the scope of delivery (P/N 053074).

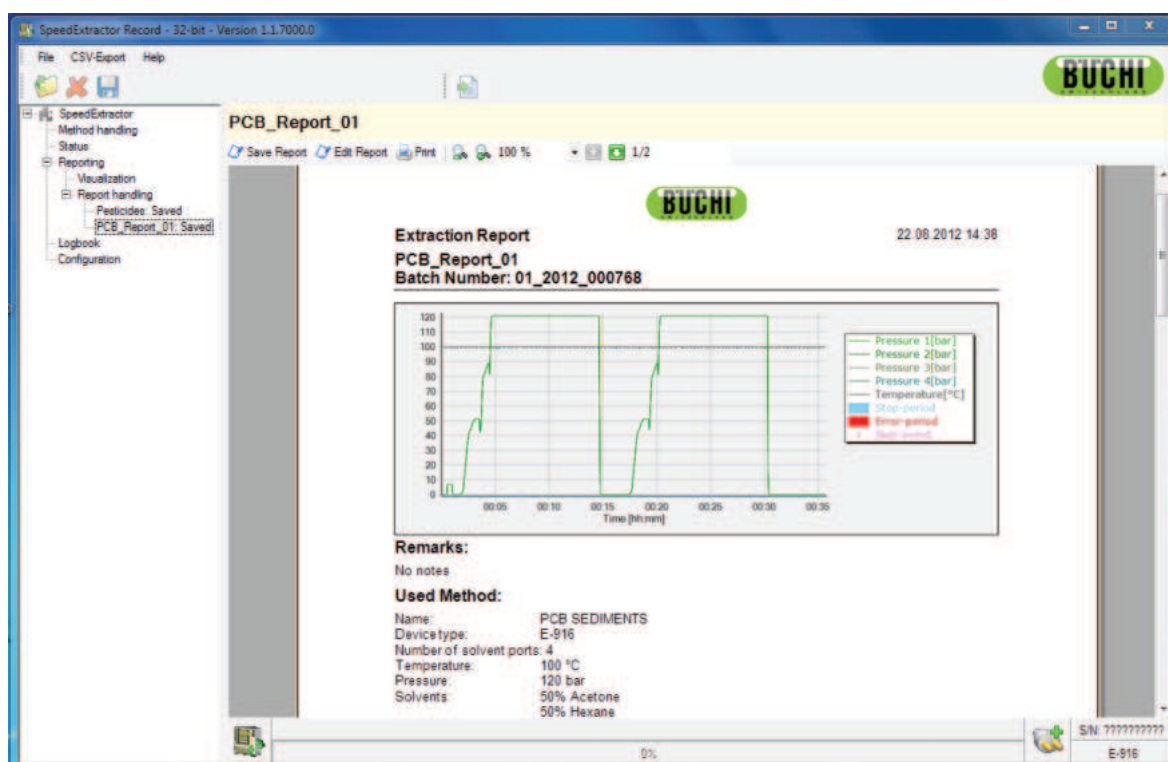

7 Maintenance

This chapter provides instructions on all required maintenance to keep the instrument in good working condition.

	WARNING
	<p>Death or serious burns by electric current at cleaning.</p> <ul style="list-style-type: none"> • Switch off the instrument • Disconnect the power cord and prevent unintentional restart • Wait until the instrument is completely dry before reconnecting the power supply

	NOTICE
	<p>Risk of housing and instrument damage by liquids and detergents.</p> <ul style="list-style-type: none"> • Do not spill liquids over the instrument or parts of it • Wipe off any liquids instantly • Use ethanol or soapy water as detergent only

7.1 Daily maintenance

Daily maintenance can prolong the system lifetime, reduce costs of service and downtime.

- Fill the solvent reservoirs according to section 6.2.1. Make sure that the filter is always completely dipped into the solvent.
- Empty the waste bottle, if needed.
- Inspect the cup seals for visual damage or contamination by sand or dust. If necessary, replace the seals according to section 7.2.1. Always perform a leak test after replacing the seals (see section 6.2.5).
- Check the nitrogen pressure (6 – 10 bar).
- Check the septa of the collection vials.
- Inspect the needles for septa residue and/or deformation.

Cleaning the seals

- If necessary, rinse the seals with organic solvent (e.g. ethanol) with the help of beaker. Always visually inspect the seals for dust, sand or scratches.

NOTE

Never clean the cup seals with a wet towel or wipe. Any kind of residue might cause a leak and/or reduce the lifetime of the cup seals.

Cleaning the upper cup seal frit

- In case of unexpected contamination, remove the top cover plate (position 4 on page 95) and clean it in an ultrasound bath.

Flushing the lines

- If the next extraction method involves a different type of solvent, flush the lines thoroughly with the new solvent as described in section 6.2.6.

7.2 Periodic maintenance

7.2.1 Sealing system

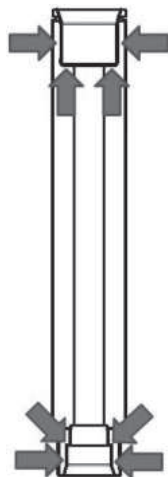

The condition of the cup seals is crucial for the tightness of the system. Any kind of contamination on either the sealing surface of the extraction cell or the seal itself significantly reduces the lifetime of the seals. Therefore, always proceed as described in section 6.3.3 to fill the cell. Rinse the seals thoroughly with organic solvent (e.g. ethanol) with a wash bottle and a beaker to collect the solvent. With clean operation the cup seals should last for approximately 100 runs. In addition, make sure that cup seal holders are not blocked by sand or dust. The holders need to be flexible to seal the extraction cells properly.

NOTE

When replacing the seals, take care not to damage them. To avoid damaging the seals, never apply grease and never touch them with sharp objects.

7.2.2 Replacing the cup seals

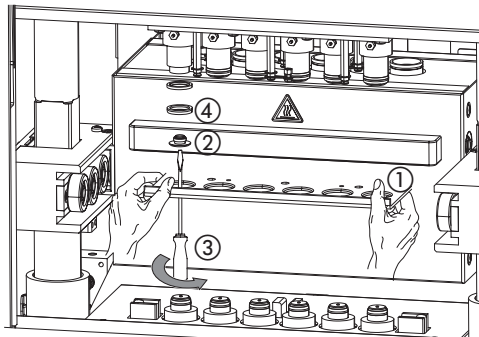

Replacing the upper cup seals

To replace the seals, push the heating block until it is locked in the back position. Optionally, remove the deflector ①. This is not mandatory to get access to the cup seals. Unscrew the top cover plate ② using the Torx screwdriver ③ (P/N 053668). The cup seal ④ can now be taken off manually and be replaced (P/N 053669 for E-916, 11069763 for E-916XL, 053671 for E-914). Be aware of the upper brown PEEK ring. They easily get lost when the cup seal is taken off. Proceed in reverse order to install the new seal. Make sure that the spring of the seals always points to the extraction cell. Perform a leak test to check the tightness of the system (see section 6.2.5).

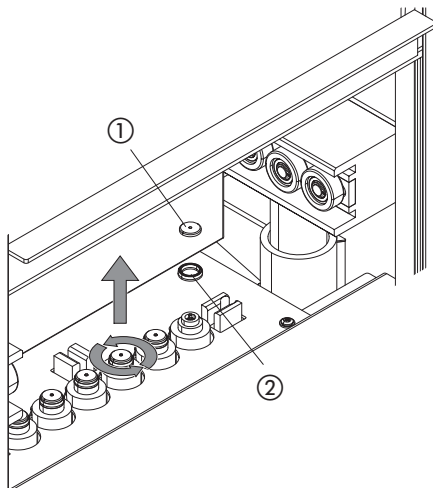

Replacing the lower cup seals

- To replace the lower cup seals, push in the heating block until it is locked in the back position. Unscrew the metal piece ① manually and pull out the seal ②.

NOTE

In contrast to the upper cup seal, no tool is required for removal of the metal piece ①.

- Replace the old seal with a new one (P/N 053670) and proceed in reverse order to install the new seal. Screw the metal piece ① hand tight. Perform a leak test to check the tightness of the system (see section 6.2.5).

NOTE

The metal piece ① has no sealing function whatsoever. Carefully screw it onto the stopper. Please check the orientation of the cup seals. Make sure that the spring always points to the extraction cell.

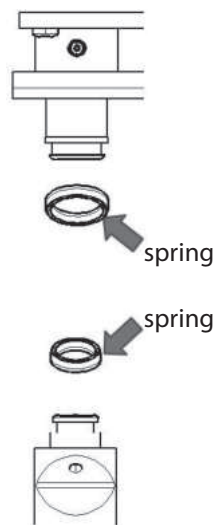

NOTE

Never remove the cup seals using your fingernails or any kind of tools, because that might damage the seals or seal holder. With the help of plastic glove the seals can easily be turned and taken off.

7.2.3 Tube connections and needles

Visually examine the tube connections on a regular basis. All tubes which are accessible without opening the housing can easily be exchanged by the operator. For all other lines please contact your local BUCHI representative.

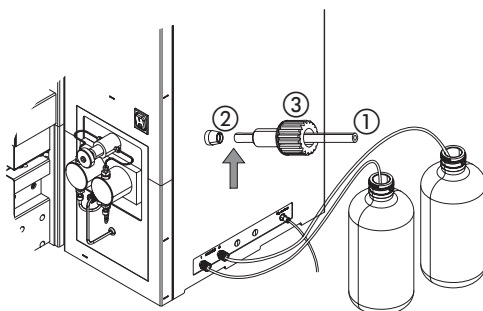

Solvent reservoir connections

The FEP tubes ① (OD 1/8", ID 1/16") are fixed with green ferrules ② and fittings ③ (1/4 UNF-28, D 1/8"). To reduce any dead volume and potential sources of contamination, make sure that the ferrule is always flush with the end of the tube. The pointed end of the ferrule is oriented to the fitting.

Exhaust connections

A good indication for clogged needles or EXHAUST lines is a reproducible residual pressure of approx. 1–2 bar after each run. In this case the lift does not open and an error message appears (see section 8.1.2). Other evidence for possibly clogged needles or lines is a difference in receiving volumes after flushing the system (see section 6.2.6). But note that there are other possible causes for unequal solvent volumes after flushing such as bent needles or clogged frits.

NOTE

The ferrules can only be used once because they get deformed when the FEP tube is fixed in place. Replacement set (qty 25): P/N 044816.

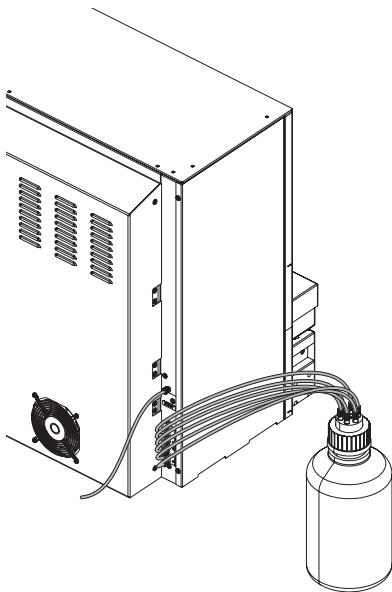

Waste connection

The FEP tubes (OD 1/16") to the waste are fixed with gray ferrules and fittings (1/4 UNF-28 D 1/16"). To reduce any dead volume and potential sources of contamination, make sure that the ferrule is always flush with the end of the tube. The pointed end of the ferrule is oriented to the fitting. Use the optional 7-port safety cap (P/N 11056948) to connect the waste tube with the waste container.

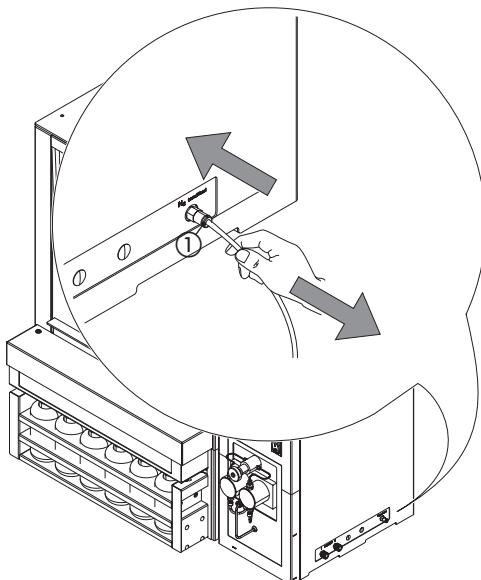

Gas connection

The line from the nitrogen tank to the instrument is connected with quick-lock mechanism. To replace the tube, make sure there is no pressure on the line, push in the inner movable part ① of the connector and take out the tube. There are no items to be unscrewed. To connect the new tube, push in the metal piece ① again and insert the new tube as far as it will go. Release the part ①. Check the tightness of the lines by closing the media valve and pressure reduction valve on the nitrogen tank and observing the pressure decrease over time. If there is constant leaking, inspect the tube and connector and replace them if necessary.

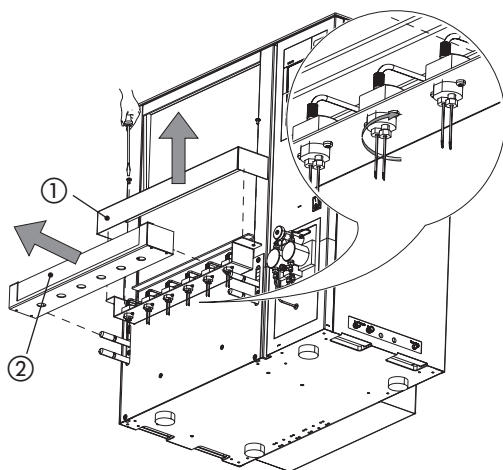

Needles

The needles need to be replaced regularly (i.e. at least after every 6 months) to reduce the risk of clogging by particles of the septa or when they are bent. To do so, remove the covers ① and ②. Unscrew the needles with the wrench P/N 053204 and pull them out from the bottom. Needles are available as sets of 12, P/N 053675. Clogged needles can be cleaned with thin wire.

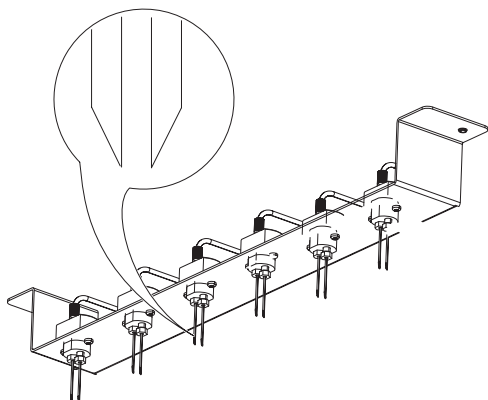

NOTE

Make sure that the sloped sides of the two needles of one position always point away from each other.

7.2.4 Septum

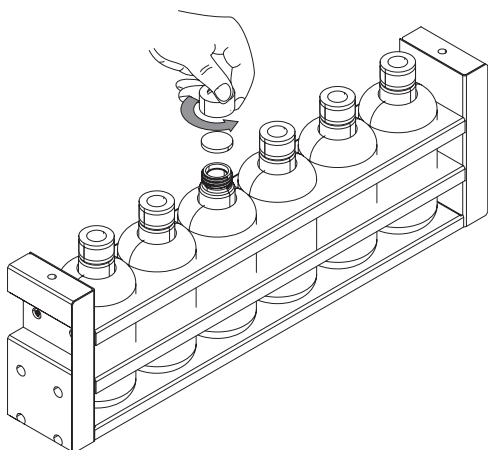

To reduce the risk of clogged needles and EXHAUST lines, replace the septa of the collection vials regularly, i.e. at least after every 5 runs.

Septum	
Vessel	Corresponding septum
Narrow-necked vials (60, 240 mL)	qty 100, P/N 049536
Wide-necked vials (150, 220 mL)	qty 12, P/N 053677

7.3 Pump maintenance

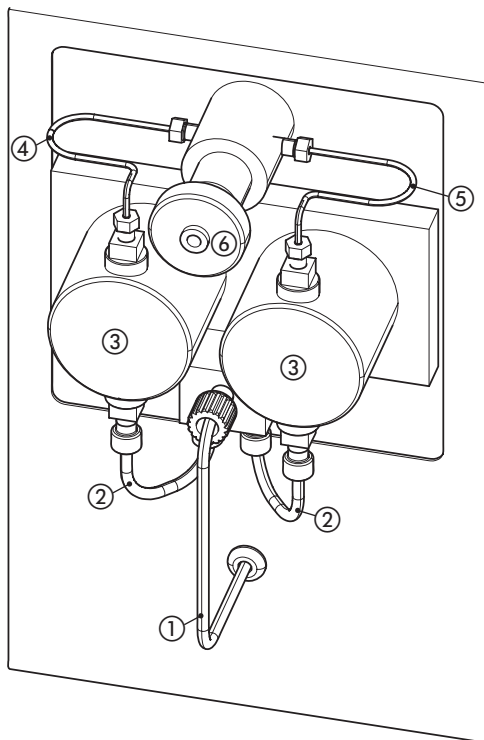

Pump designations

- ① Mixer outlet line
- ② Pump inlet lines (left, right identical)
- ③ Pump heads
- ④ Pump outlet capillary left
- ⑤ Pump outlet capillary right
- ⑥ By-pass valve

7.3.1 Connections



FEP tubings

Use FEP tubing OD 1/8", ID 1/16" for the mixer outlet and pump inlet lines. Make sure that the ferrule (P/N 053664) is flush with the end of the tubing. After the tubing has been prepared in this way, screw it into the input block while continuously pressing the tubing to the inside until the end of the tubing is firmly seated on the bottom of the opening.

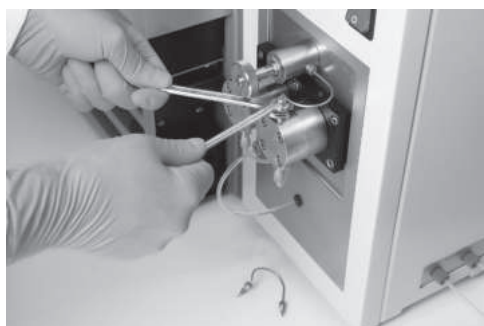

Outlet capillary

Unscrew the capillary from the outlet opening using a 1/4" spanner wrench. Use 1/16" x 1 mm outlet capillaries on which a ferrule and a screw are placed left: P/N 053613; right: P/N 053614. In contrast to the FEP tubing, the ferrule on the metal capillary should head out of the screw. Screw the capillary prepared in this way into the corresponding connection using a 1/4" spanner wrench while continuously pressing the capillary to the inside until the end of the capillary is firmly seated on the bottom of the opening bottom.

7.3.2 Back washing

Back washing is an important maintenance procedure when not only pure and filtered solvents are used such as for example buffer solutions.



The pump consists of two heads for alternate pumping and purging. They are both equipped with a Luer cone in the upper part, into which a plastic syringe (P/N 034882) can be inserted as shown in the picture. Both heads are equipped with piston seals (P/N 053612). When operating with buffer solutions, there is a risk that buffer crystals stuck on the piston might damage the seal, causing the pump to begin leaking.

Therefore, after termination of the operation, it is necessary to flush the lines and the pump vigorously with clean solvent, which dissolves the buffer, and, at the same time, to wash the rear part of the piston in the purging head.

8 Troubleshooting

The following chapter describes how to resume operation of the instrument in the event of any minor problem. It lists some possible occurrences, their probable cause, and suggests how to remedy the problem. The troubleshooting table below lists possible malfunctions and errors of the instrument and describes operator-enabled courses of action to correct some of those problems. The appropriate course of action is listed in the column "Remedy".

More complicated malfunctions or errors are usually handled by a BUCHI technical engineer who has access to the official service manuals. In this case, please contact your local BUCHI customer service agent.

8.1 Malfunctions and their remedy

8.1.1 Action in case of a fire

Abort the extraction process, close the safety shield of the ventilation hood and turn off the nitrogen supply. Draw the fire with a CO₂ fire extinguisher.

8.1.2 General malfunctions and their remedy

In the following table, X refers to the position in the heating block, starting from left to right.

General malfunctions and their remedy			
Malfunction	Display information	Possible cause	Remedy
Error 1	Not defined		
Error 2	Heater temperature out of range ($\Delta T > 30\text{ }^\circ\text{C}$). Start not allowed. Please refer to user manual.	Preheating has not yet reached the set temperature of the method. Extraction or leak test cannot be started.	Wait until the instrument has reached equilibrium. Take out the extraction cells if the temperature is far out of range. If this occurs frequently, contact BUCHI customer service. The heater may have a problem.
Error 3	Heater temperature out of range. Start anyway?	Occurs when the previous method was run at a higher temperature than the current one. The oven temperature is too high (i.e. $\Delta T > 3\text{ }^\circ\text{C}$ higher than the set temperature).	Wait until the instrument has cooled down to the set temperature to achieve equilibrium and reproducible conditions. Cooling may be accelerated by placing cold cells into the heating block. Switch back to sample cells when the set temperature is reached. Alternatively, extraction or leak test can be started anyway if reproducibility is not so important.
Error 4	Change vials.	The collection vials need to be changed, because collection of the next cycle would cause overflow (see section 6.4.3).	Replace the vessels in the collection tray with empty ones.

General malfunctions and their remedy			
Malfunction	Display information	Possible cause	Remedy
Error 6	Heatertimeout.Temperaturenot achieved. Please refer to user manual.	Temperatureisnotwithin $\pm 3^{\circ}\text{C}$ of the set temperature after 60 min preheating time.	Acknowledgethemessageand wait until the temperature is reached.Ifthisoccursfrequently, contactBUCHlcustomerservice. Theheatermayhaveaproblem.
Error 7	Method not complete.	Parameters of the extraction methodarenotdefined,resulting inanambiguousmethodthat is not reproducible.	Compleatetheextractionmethod in theEDITMETHODmenuand save again. See also section 6.4.3.
Errors related to the motor lifting the heating block.			
Error 8	Lightbarriermalfunctioncelllift. Please refer to user manual.	Thelightbarrierisdisconnected or covered.	ContactBUCHlcustomerservice.
Error 9	Heatingblocknotinstart position.Pleasebringheatingblock to start position.	Heating block is not properly placed in the middle position.	Movetheheatingblockforward or backward until it snaps in place. See section 6.4.1.
Error 10	Shield not closed. Please close shield.	Thecellliftwillnotmoveaslong as the shield is open.	Close the shield and press START again.
Error 11	Power consumption of cell lift motor too high. Please check if heatingblockisblocked.Please refer to user manual.	Theliftismechanicallyblocked.	Inspect the lift for physical blockage. Contact BUCHl customerserviceifthe problem persists.
Error 12	Targetpositionofheatingblock not achieved. Please check if heatingblockisblocked.Please refer to user manual.	The lift does not reach its final destinationwithina giventime because of a motor or light barrier problem.	ContactBUCHlcustomerservice.
Error 13	Cell lift motor blocked. Please refer to user manual.	The lift does not move at all, most probably due to a faulty v-belt or motor.	ContactBUCHlcustomerservice.
Error 14	No power consumption of cell lift motor. Please refer to user manual.	Themotoriseitherdisconnected or damaged.	ContactBUCHlcustomerservice.
Errors related to the motor lifting the collection rack.			
Error 15	Lightbarriermalfunctionviallift. Please refer to user manual.	Thelightbarrierisdisconnected or covered.	ContactBUCHlcustomerservice.
Error 18	Power consumption of vial lift motor too high. Please check if vialrackisblocked.Please refer to user manual.	Theliftismechanicallyblocked.	Inspect the lift for physical blockage. Contact BUCHl customerserviceifthe problem persists.
Error 19	Target position of vial rack not achieved. Please check if vial rack is blocked. Please refer to user manual.	The lift does not reach its final destinationwithina giventime because of a motor or light barrier problem.	ContactBUCHlcustomerservice.
Error 20	Vial lift motor blocked. Please refer to user manual.	Theliftdoesnotmoveatallmost probablyduetoafaultyv-beltor motor.	ContactBUCHlcustomerservice.

General malfunctions and their remedy

Malfunction	Display information	Possible cause	Remedy
Error 21	No power consumption of vial lift motor. Please refer to user manual.	The motor is either disconnected or damaged.	Contact BUCHI customer service.

Errors related to pressure sensors or pressure in general.

Error 22	Calibration of pressure sensor not successful. Please refer to user manual.	A pressure sensor is defective.	The defective pressure sensor needs to be replaced. Contact BUCHI customer service.
Error 23 to error 28	Calibration of pressure sensor to Cell X not successful. Please refer to user manual.	The pressure sensor at position X is defect.	The defective pressure sensor needs to be replaced. Contact BUCHI customer service.
Error 29 to error 34	Cell X clogged: press START to disable position or repeat to discharge.	The pressure at position X after discharge is too high (between 1 and 80 bar).	Press REPEAT to discharge again. If the error message occurs again, follow the instructions outlined in section 8.1.3.
Error 35 to error 40	Position X clogged: press repeat to discharge or relieve the pressure manually. Please refer to user manual.	The pressure at position X is too high (>80 bar).	Press REPEAT to discharge again. If the error message occurs again, follow the instructions outlined in section 8.1.3.
Error 41	Several positions are clogged: please repeat to discharge, or relieve the pressure manually. Please refer to user manual.	Error 41 occurs when more than one position is clogged.	Press REPEAT to discharge again. If the error message occurs again, follow the instructions outlined in section 8.1.3.
Error 42	A clogging occurred during extraction. Do you want to open the cell lift? Alternatively, relieve the pressure manually.	Error 42 always occurs at the end of an extraction process when clogging occurred before (error 29 – 41).	Follow the instructions outlined in section 8.1.3.
Error 45 to error 50	Position X: Pressure too low. Please check whether a cell is inserted. Please refer to user manual.	Not all activated positions are occupied with an extraction cell.	Pull out the heating block and occupy the vacant positions. NOTE It is generally recommended to accommodate all positions to achieve best reproducible results. See also 6.2.4.

General malfunctions and their remedy			
Malfunction	Display information	Possible cause	Remedy
Error 51	Pump pressure too high. Please refer to user manual.	During Extraction	Check the state of the media, position and outlet valve. Open the corresponding valve(s) in the SERVICE FUNCTIONS > VALVE menu. Calibrate the rotating valves (media and outlet valve) if necessary.
		<p>The pump is purging against a closed system, i.e. a closed valve.</p> <hr/> <p>During LEAK TEST:</p> <p>Press OK to confirm the error. The cell lift will open and the LEAK TEST is finished. Calibrate the pressure sensors to correct the error!</p>	<p>Calibration procedure:</p> <p>Enter the SERVICE FUNCTIONS > VALVE menu and open the position and outlet valves.</p> <p>To calibrate the pressure sensors enter the SERVICE FUNCTIONS > SENSORS menu. Press NEXT and start calibration by selecting CALIBRATE.</p> <p>Close all corresponding valves again. Re-run the LEAK TEST to verify the calibration!</p>
Error 52 to error 57	Position X: Pressure too high. Please refer to user manual.	During Extraction	Relieve the pressure manually by opening the drain valve. Follow the instructions outlined in section 8.1.3.
		<p>The pressure at position X is too high, most probably due to clogging of the sample in the extraction cell during operation.</p> <hr/> <p>During LEAK TEST:</p> <p>Press OK to confirm the error. The cell lift will open and the LEAK TEST is finished. Calibrate the pressure sensors to correct the error!</p>	<p>Calibration procedure:</p> <p>Enter the SERVICE FUNCTIONS > VALVE menu and open the position and outlet valves.</p> <p>To calibrate the pressure sensors enter the SERVICE FUNCTIONS > SENSORS menu. Press NEXT and start calibration by selecting CALIBRATE.</p> <p>Close all corresponding valves again. Re-run the LEAK TEST to verify the calibration!</p>
Error 58	No position selected. Please select at least one position.	The positions accommodating the samples are not selected.	Select the corresponding positions: EXTRACTION → OCCUPIED POSITIONS. See also section 6.2.4.
Error 59	Nitrogen inlet pressure out of range. Please check nitrogen supply.	Nitrogen tank is not connected or empty.	Check the pressure and connection of the nitrogen tank. See also section 5.3.

General malfunctions and their remedy			
Malfunction	Display information	Possible cause	Remedy
Error 61 to error 64	Solvent valve X: Does not close. Please refer to user manual.	The solvent valve X or connection to the valve is faulty and needs to be exchanged or repaired.	Connect the solvent bottle to a different port (if possible) and manually select the new position in the menu EXTRACTION → EDIT METHOD → SOLVENT. Contact BUCHI customer service to exchange the defective parts.
Error 66	Pressure not reached. Pump timeout. Please check solvent reservoir. Please refer to user manual.	The set pressure is not reached within a given time period. The most probably causes are an empty solvent reservoir, a clogged filter, an interruption in the solvent connection, or a severe leak. In the latter case, this can be heard and in most cases can be smelled.	Depending on the cause proceed as follows: – Fill the solvent reservoir – Clean the filter – Replace the solvent lines. Try to locate the leak. If obvious remedies, such as replacing a seal do not get anywhere, contact BUCHI customer service.
Error 67	No communication with pump. Please refer to user manual.	The pump is not supplied with current.	Contact BUCHI customer service.
Error 68 to error 73	Position valve X: Does not close. Please refer to user manual.	The position valve X or the connection to the valve is faulty and needs to be replaced or repaired.	Contact BUCHI customer service.
Error 74	Target position of media valve not achieved. Please refer to user manual.	The media valve or connection to the valve is faulty and needs to be replaced or repaired.	Calibrate the media valve as described in section 8.2.1. If the problem remains, contact BUCHI customer service.
Error 75	Target position of outlet valve not achieved. Please refer to user manual.	The outlet valve or connection to the valve is faulty and needs to be replaced or repaired.	Contact BUCHI customer service.
Error 76	Pump pressure out of range. Please refer to user manual.	The overall pressure sensor (located between media valve and divider) or connection to the sensor is faulty and needs to be replaced or repaired.	Contact BUCHI customer service.
Error 77 to error 82	Position X: Pressure out of range. Please refer to user manual.	The pressure sensor located between the position valve and extraction cell is faulty and needs to be replaced.	Contact BUCHI customer service.

8.1.3 Handling and resolving blockages

When a position gets clogged, the pressure is not relieved when the outlet valve opens and discharges the extract. As a result, the pressure remains high in this clogged position. This entails two problems: Firstly, there is a possible chance of cross contamination between the pressurized clogged position and the adjacent low pressure positions during the heat-up step of the subsequent cycle. Secondly, the cell lift does not open when the process is finished to avoid splashing of the sample. There are different reasons why blockages can occur during extraction under high pressure and high temperature using the SpeedExtractor E-916 / E-914: inappropriate sample preparation, extraction parameters, or instrument configuration. Often a combination of these factors can cause blockages.

- An appropriate sample and cell preparation is important to avoid blockages. The use of glass fiber filters and/or thimbles is recommended for sticky, fine powdery and polymer samples. See section 6.3.
- An optimized method is essential. Control the following parameters: temperature, solvent, numbers of cycles and hold time. Too high temperatures can lead e.g. to melting of polymer samples. A short first cycle can be helpful for samples with high concentration of analyte (e.g. fat in food samples). For more detailed information about sample preparation and method development, consider BUCHI's Application Notes, Technical Notes and the SpeedExtractor Application Booklet. Please contact your local representative or BUCHI for these documents.
- Some samples are prone to precipitate upon passing through the cooling unit during the discharge step. The shorter cooling unit (P/N 053682) does not cool down the sample that much and hence reduces the risk of precipitation.

NOTE



The method development of a new unknown sample should be carried out on only one position, preferably position 1. If it is necessary to replace parts for cleaning, position 1 is the position which can be reached most easily. If a clogging occurs during the method development step, it is possible to continue with further extractions using the remaining positions.

At the end of the discharge step pressure sensors at the activated positions will check if the pressure is released before continuing with the next step (another cycle or flush with solvent or gas). If the pressure has not been released to <1 bar, an error message will be shown and the operator should then follow the instructions. Following the error messages, it will be necessary to release the pressure manually.

Relieving pressure manually

Open the drain valve manually using the bit wrench P/N 052783. Opening the drain valve results in a hot steam of solvent for a quick moment. In order to prevent possible splashing, open the safety shield and put a towel around the clogged position. Close the drain valve and the shield when finished.



	CAUTION
	<p>Risk of minor or moderate injuries by hot steam of solvent when opening the drain valve.</p> <ul style="list-style-type: none">• Use a towel or insulated gloves for protection

There are three cases to distinguish depending of the pressure in the clogged position and the number of clogged positions. In the following paragraphs, the work flows of the different scenarios are explained with flow charts.

Pressure <80 bar in clogged position (Errors 29 – 34, see section 8.1.2 for error messages)

In the flow chart is shown that the SpeedExtractor will be in the “wobble position”. This means that the heating block is slightly moving up just to increase the volume inside the extraction cell. The position is still tight, but the pressure will be decreased due to the larger volume now inside the cell.

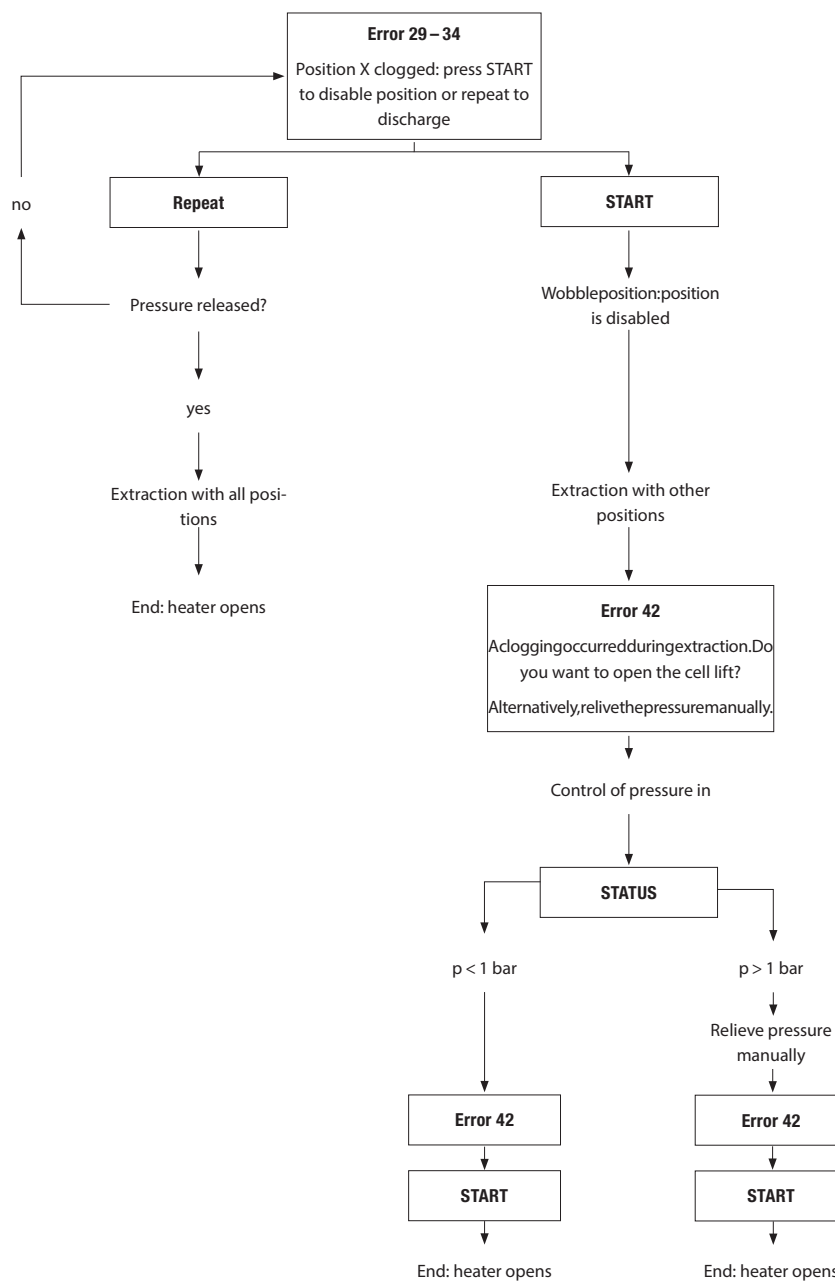

Pressure >80 bar in clogged position (Errors 35-40)

If the pressure in the position is above 80 bar, the instrument will not be in the “wobble position”. This means that the heating block is not moving and the pressure will not decrease automatically, and so must be released manually, see above. “//” indicates that it does not make sense to follow this way due to moving in circles.

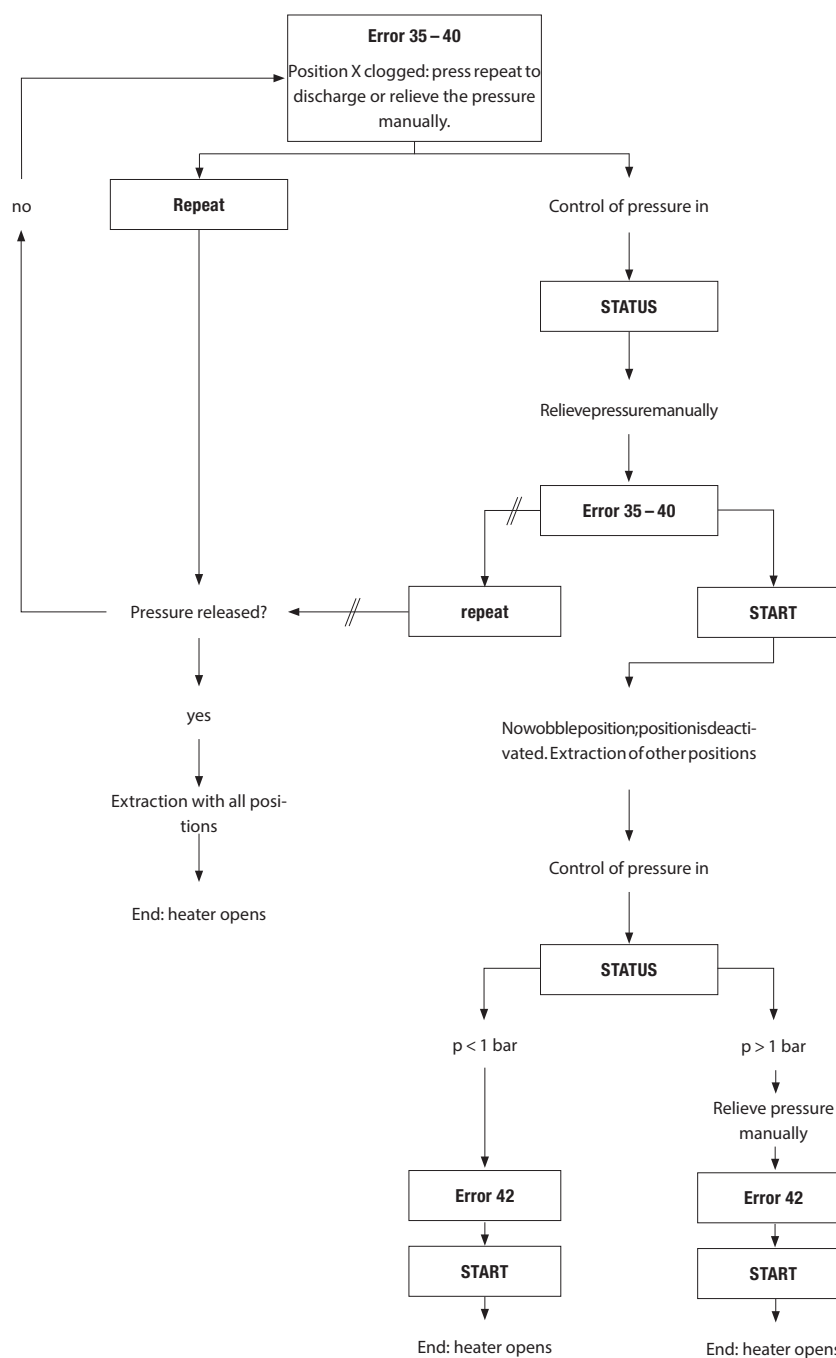

More than one position is clogged (Error 41)

Once the SpeedExtractor has shown the error messages 29 – 34, 35 – 40 or 41 and the pressure is released following the instructions given in the flow charts, it is then necessary to locate the blockage. To do so, insert empty cells without filter papers, metal frits and plugs in the positions in question. Start a flush into the collection vials (see section 6.2.6). If solvent flows into the vials, the cell (sample inside the cell, the filter or frit) was blocked. If solvent does not flow into the vial, the SpeedExtractor is blocked and further steps are necessary.

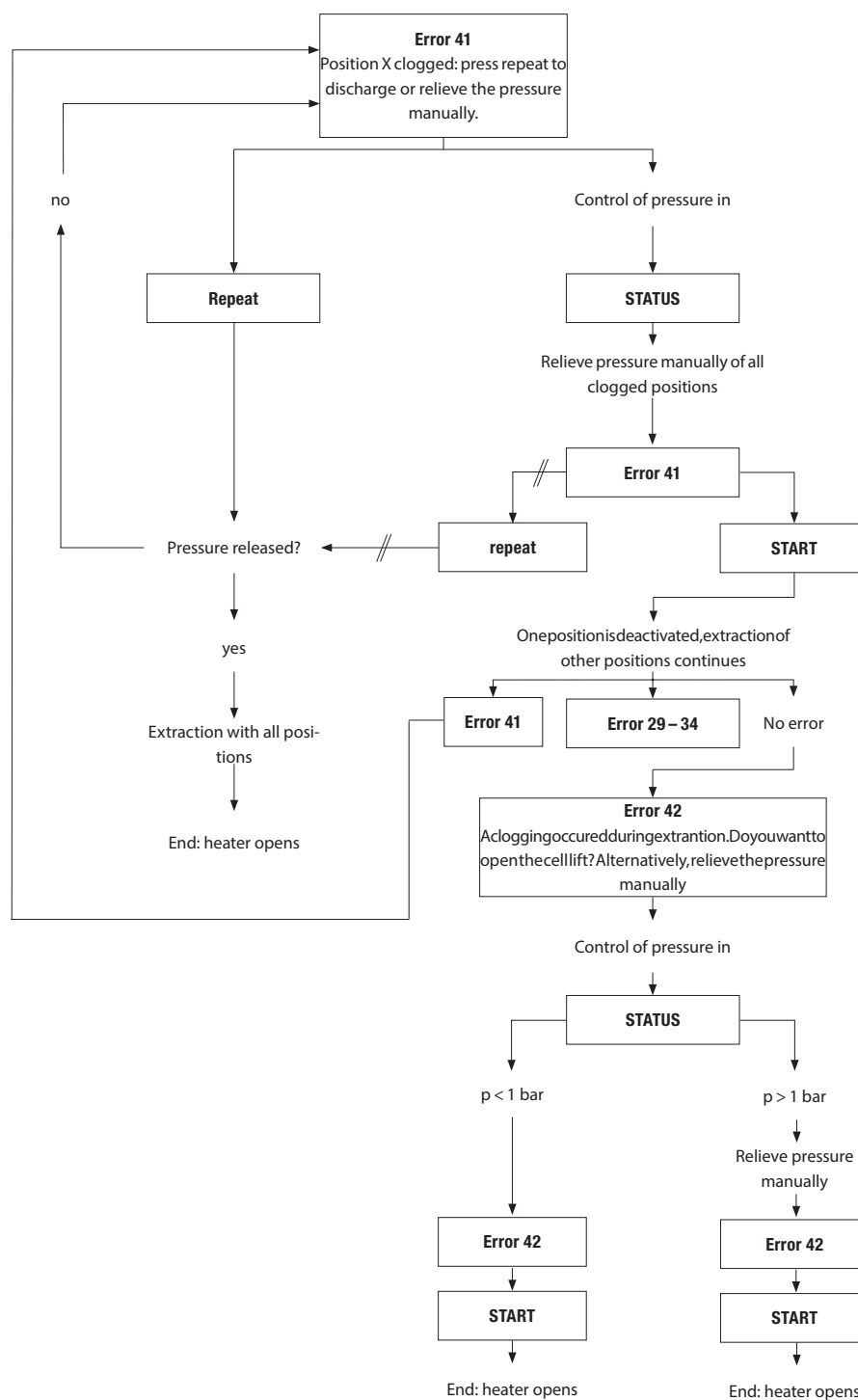

Blockages may be pushed out under extreme conditions. Therefore an extraction with the following conditions should free the lines.

- Extraction conditions: temperature 200 °C, pressure 150 bar, 1 cycle, hold 10 min, discharge 5 min, flush with solvent 2 min and flush with gas 5 min. Use the same solvent, cell and vial size as for the extraction when the blockage appeared.
- If the SpeedExtractor is still blocked after this extraction it will be necessary to identify the blocked part. The flow test in the service menu allows locating the blockage within the instrument. See section 8.2.4.

8.1.4 The pump is not aspirating properly

NOTE

When the pump is running but the solvent is not aspirated check first if the right solvent port is selected (see section 6.2.6).

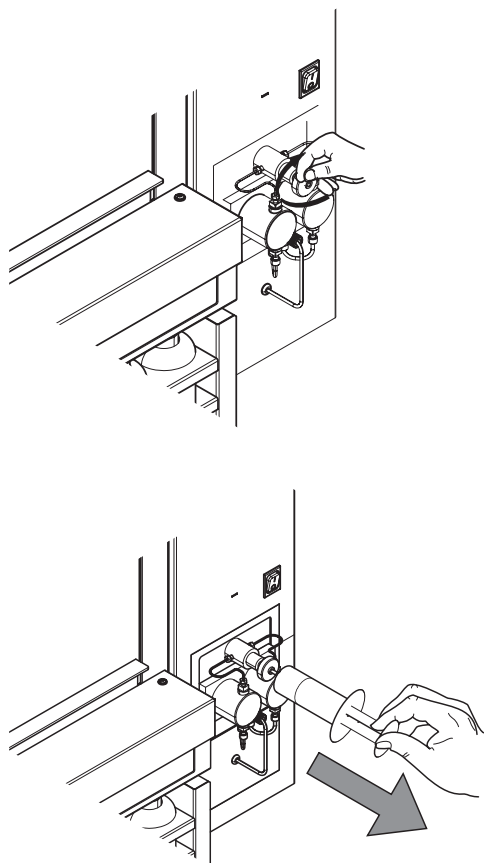

A new pump or a pump that has been out of operation for a long time may sometimes be difficult to start. The cause is a dried out solvent on the check valves and air bubbles stuck on the pumping mechanism. Both causes result in pressure fluctuations, or solvent intake fails completely.

- Visually inspect the connections, lines, and filter of the solvent reservoir. Replace items if necessary as described in section 6.2.1 and 7.3.1.
- If the pump is still not purging properly, assistance by means of a syringe is sufficient in most cases. Slacken the by-pass valve. Turning by 90° counter-clockwise is sufficient.
- Suck up a solvent using a plastic syringe until the pump stops producing bubbles. Empty the syringe, attach it again, start the pump, and watch to see whether the pump sucks regularly and all bubbles have been eliminated. Once the pump is working properly, close the by-pass valve and keep the pump running for a while.
- If pumping is still irregular, leave the pump running for approximately 10 minutes and observe whether the pump pumps regularly and all bubbles have been eliminated. If the problems persist, repeat purging (with the by-pass valve slackened).
- If the problem still persists equip the syringe with a pointed cannula that fits into the intake FEP tube (ID 1/16") and fill the syringe with the solvent used for the extraction method. Press some solvent into the tube while the pump is running and dip it into the solvent reservoir as soon as the pump begins aspirating.

NOTE

The syringe P/N 034882 is made of polypropylene and is therefore not compatible with halogenated solvents (i.e. dichloromethane) and acids.

8.1.5 Replacement of check valves



The principle of a check valve is a precise ball and seat located in a casing of PEEK material with stainless steel reinforcement. By a stream of liquid the ball is pressed down to the seat, thus creating a seal. With respect to high pressures in the pump, any minute impurity stuck on the surface of the ball or the seat causes pressure fluctuation, or the pump fails to start at all. If you do not succeed in correcting these problems by repeated purging, it is necessary to replace or clean the valves.

Replacement of the outlet and inlet check valve

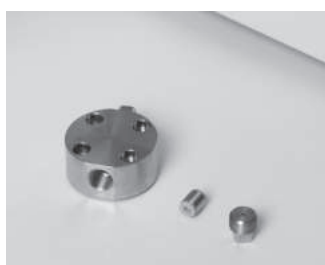
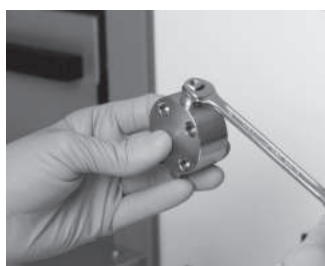
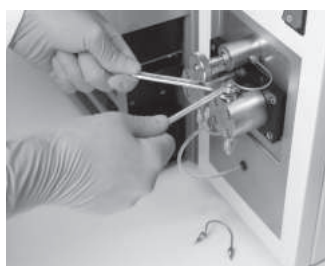

- Screw out the nut on the valve holder using a 1/4" and 8 mm spanner wrench, and take off the capillary.
- Unscrew the fittings of the pump inlet lines.
- Unscrew the four nuts from the head using a 3 mm allen wrench.
- Carefully remove the pumping head.
- Unscrew the valve holder using a 8 mm spanner wrench.
- Remove the valve from the pumping head using tweezers.
- Insert the new valve in the same direction, i.e. with the four holes upwards.
- Proceed similarly with the inlet check valve at the bottom side of the pump head. The four holes on the valve should always point in the direction of the pumping head, so that the inserted valve has a visible part with one hole.
- Proceed in reverse order to reassemble the pump. Tighten all nuts and, when starting the pump, check whether any connection is leaking.
- Attempt to clean the valves in acetone using ultrasound (or in another solvent), which dissolves the buffers you have been using.

Replacement of seals

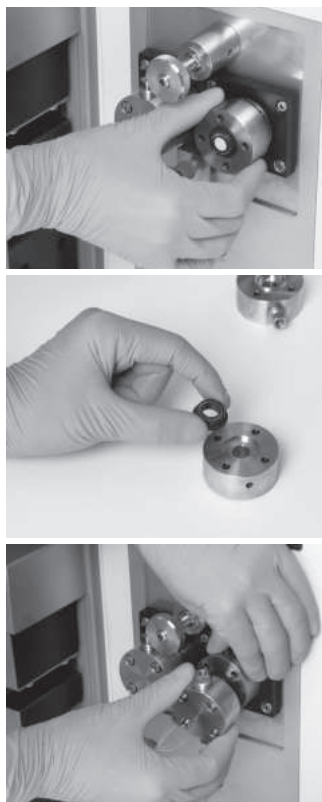

A damaged seal manifests itself in the form of pressure fluctuations, and drops of solvent begin to appear below the opening of the backwash head. Replacement of the seal is the same in both pumping blocks.

- Carefully remove the purging head.
- Remove the defective seal with a blunt object or by hand.
- Insert the new seal and carefully put the purging head on the piston.
- Put the pumping head on the piston. Tighten the four nuts on the pumping head. Be careful of the orientation of pumping head; the outlet check valve must face upward.

Fit the capillaries and tubing in the reverse order as in disassembly.

Proceed according to the section "Replacement of outlet and inlet check valves" and check whether all connections are leak free under operating pressure.

8.1.6 Precipitation in the outlet lines

Some samples are prone to be precipitated upon passing through the cooling unit during the discharge step. To identify possibly clogged lines, perform a flow test (see section 8.2.4). When the relative back pressures of the line exceed 10 bar, the line is either contaminated with sample or particles of the septa (see sections 7.2.3 and 7.2.4) or are deformed. Check the needles first and clean or replace them if necessary (see section 7.2.3).

Try to clean the lines by flushing them thoroughly with a suitable hot organic solvent heated up in the extraction cells. To do so run an extraction process with empty extraction cells (with high temperatures, high pressure and long hold time, see section 8.1.3). If the solvents in the collection vials during a new flushing procedure is still differing considerably, the lines are most probably still contaminated with residues or deformed. In this case, the lines from the heating block to the collection tray, including the cooling unit, need to be replaced by a service technician.

For samples which are prone to be precipitated from the extract solution, setting the hold time of the first cycle to 0 min often eliminates the problem. Alternatively, there is a shorter cooling unit available which does not cool down the sample that much and hence reduces the risk of precipitation. The alternative cooling unit (P/N 053682) must be installed by a BUCHI approved service technician. Please refer to your local dealer or BUCHI customer service.

8.1.7 Malfunctions of the rotating valves

The outlet and media valves are rotating valves with a defined start position. This reference point can get lost. In consequence, the extracts are transferred in wrong position (e.g. into waste instead of vials) for the outlet valve, or the solvent mixture at the media valve is misdirected to the nitrogen inlet instead of the divider.

The rotating valves can be calibrated in the SERVICE menu. For this purpose, proceed as follows:

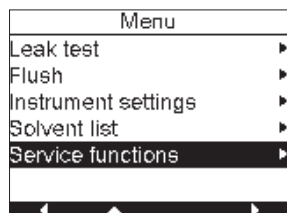

Go to MENU.

Select the SERVICE FUNCTIONS.

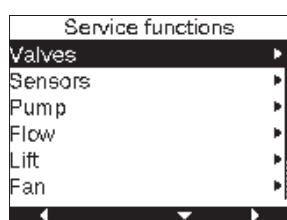

Select VALVES.

Push the right arrow button. First you see the solvent valves. Press NEXT to get to the MEDIA VALVE display.



Press the down button to activate CALIBRATE and confirm with SELECT.

You will hear the rotating valve finding the correct start position.



Proceed similarly with the outlet valve or when the message "Outlet valve: connection lost" appears.

You will hear the rotating valve finding the correct start position.

NOTE

The firmware release FW 01.02 and later calibrate the rotating valves automatically at the first extraction or leak test (FW 01.03 and later) when the instrument is switched on. This reduces the chance of malfunctions due to lost connections significantly.

8.1.8 Upgrading a 2-port mixer to a 4-port mixer

A BUCHI-approved service technician can retrofit a 2-port configuration with a 4-port mixer (P/N 053381). Please contact the local dealer or BUCHI customer service.

8.2 Description of the service menu

The service menu provides direct access to all technical process components such as valves, sensors, pump, lift and fan independent of any extraction method. It is therefore possible to switch valves, run the pump or move the lift for troubleshooting purposes. In addition instrument information is available, like operating hours and version of certain components.

To open the service menu proceed as follows:

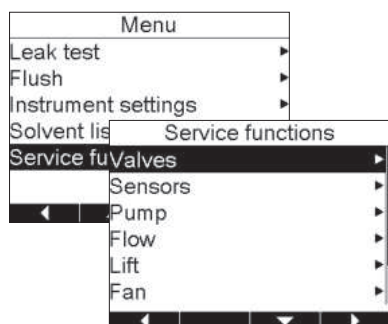

Go to MENU → SERVICE FUNCTIONS and press the right arrow.

The following information appears:

Safety advice: The Service Functions allow several operations without proceeding safety checks.

Press YES to continue.

All available service functions are listed and separately accessible in a submenu. For thorough description of the submenus see the following sections.

The following table provides an overview of the available submenus, their function and typical usage:

Description of the service menu		
Service function	Description	Typically used for:
Valves (see 8.2.1)	The status of all valves, i.e. solvent valves, media valve, position valves and outlet valve are shown in a separate submenu. It is possible to open or close each valve separately to check their function.	To check whether the valve is operating or to calibrate the rotary valves.
Sensors (see 8.2.2)	There are three different types of sensors which are individually accessible by a submenu. Position switches check the position of the cell and vial lift, the heating block, the protective shield and the presence of the collection rack. Seven (for the E-916) or five (for the E-914) PRESSURE SENSORS monitor the pump pressure as well as the pressure for each position individually. These values are also shown in the main and the status display. The temperature of the heating block and the main board is shown in the TEMPERATURE SENSORS submenu. The heater temperature is also accessible in main display.	To check the safety function of the position switches and to get an overview of pressure and temperature values.
Pump (see 8.2.3)	The pump submenu makes it possible to run the pump independent of any extraction process at flow rates of 1 – 50 mL/min.	After service to check its function.
Flow (see 8.2.4)	With the help of the flow function the back pressure of each line can easily be checked. A relative comparison of the pressure makes it possible to quickly identify positions with possibly clogged lines, particle precipitation or capillary deformations.	To identify possible clogging of the lines.

Description of the service menu		
Service function	Description	Typically used for:
Lift (see 8.2.5)	The lift for the heating block (cell lift) and the collection rack (vial lift) can be moved up and down. Light barriers show the corresponding position and the used current indicates possible blockage of the lift.	To open the cell lift after manual draining of the extract in case of clogged cells. To check the proper interaction of the lift and light barriers.
Fan (see 8.2.6)	The instrument is equipped with two fans: Fan Extraction (default 30 %), Fan Electronic (default 30 %)	To regulate the instrument temperature
Operating hours (see 8.2.7)	The number of extractions and leak tests as well as the operating hours of the instrument are shown. Further information like highest achieved temperature or pressure is also shown.	Apart from pure information, peak values might reveal causes for possible problems.
Unit information (see 8.2.8)	The unit information submenu contains specifications of the instrument and certain components such as serial number and firmware version which are helpful in case of troubleshooting.	To check the version of the instrument, firmware etc.

8.2.1 Checking the valves

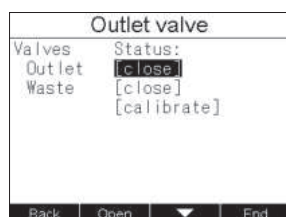
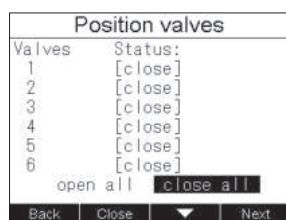
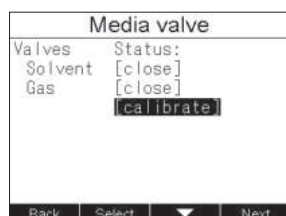
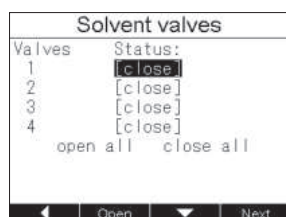

Go to SERVICE FUNCTIONS → VALVES. Depending on the type of mixer, 2 or 4 solvent valves with their current status are shown. Press OPEN or CLOSE to change the status of each valve individually or OPEN ALL or CLOSE ALL for all together. The solvent valves are magnetic valves. An audible click occurs when the valve is switched.

Press NEXT to enter the MEDIA VALVE submenu. The media valve is a rotary valve which connects the pump outlet or the nitrogen supply with the divider (see section 4.4). Change the status by pressing OPEN or CLOSE. To move the rotary valve back to defined initial position press CALIBRATE.

Press NEXT to enter the POSITION VALVES submenu. The status of the six (for the E-916) or four (for the E-914) position valves is shown and can be changed individually (OPEN, CLOSE) or all together (OPEN ALL, CLOSE ALL).

Press NEXT to enter the OUTLET VALVE submenu. Like the media valve, the outlet valve is also a rotary valve which can be calibrated apart from changing the status. Press CALIBRATE to move the valve back to its initial position. Pressing END shows the STATUS display with the current settings. Press END to go back to the SERVICE FUNCTIONS.

8.2.2 Checking the sensors

Light barriers		
Cell	Present [X]	Present [X]
Cell	Present [X]	Present [X]
Heater	Present [X]	Present [X]
Shield	Present [X]	Present [X]
Rack	Present [X]	Present [X]

Pressure sensors	
Pump	0.0 bar
Position 1	0.0 bar
Position 2	0.0 bar
Position 3	0.0 bar
Position 4	0.0 bar
Position 5	0.0 bar
Position 6	0.0 bar

Temperature sensors	
Heater:	21 °C
Electronic:	26 °C

Go to SERVICE FUNCTIONS → SENSORS. The position of the lift for the heating block (CELL), the lift for the collection rack (VIAL), the heating block (HEATER), the protection shield (SHIELD), and the presence of the collection rack (RACK) is shown. Crossed brackets [X] indicate the present position.

Press NEXT to enter the PRESSURE SENSORS submenu.

The overall pressure between the media valve and the divider (indicated by PUMP; see section 4.4) and depending on the type of instrument the pressure of the six or four position valves is shown.

Press CALIBRATE to calibrate the pressure sensors to 0 bar.

Therefore the instrument must not be under pressure, so open the heater and the positions valve before calibration.

Press NEXT to enter the TEMPERATURE SENSORS submenu.

The temperature is shown for the heating block and the main board (PCB).

Press END to go back to the SERVICE FUNCTIONS.

8.2.3 Running the pump

Pump	
Flowrate:	1 mL/min
Actual value:	48 mL/min
Pressure:	0.0 bar

Go to SERVICE FUNCTIONS → PUMP. Enter the flow rate using the selection knob (1 – 50 mL/min). Press ON. The ACTUAL VALUE converges to the set value. If the ACTUAL VALUE remains 0, the pump is defective. Contact a BUCHI service engineer.

The actual pressure is shown.

NOTE

Never run the pump dry. Never run the pump against a closed valve. Solvent may get in the instrument when the extraction positions are empty or the lift is not closed.

Go back to the SERVICE FUNCTIONS with the left arrow.

8.2.4 Inspecting the lines (flow test)

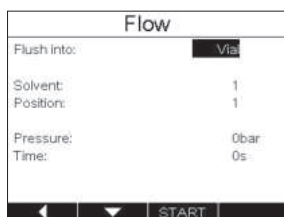

Go to SERVICE FUNCTIONS → FLOW. Define the parameters using the selection knob. Press START to start with the flow test.

- Place empty extraction cells (no sand, no expansion element, no plug screw) into the heating block and empty vials in the collection rack (see section 6.4.1). Close the cell and vial lift manually (see section 8.2.5). Use the same solvent as used during the extraction when the blockage occurred. Note the value after the system runs stably, i.e. typically after 30 – 60 s.
- The pump runs at 50 mL/min and generates a certain back pressure. If the position is not blocked, the max. pressure will be 8 bar. If the position of the tested part of the SpeedExtractor is blocked, the pressure will increase and it will be necessary to release the pressure manually, see section 8.1.3. Depending on the blocked part of the SpeedExtractor it is necessary to perform several flow tests. Proceed according to the following scheme to locate the blocked part.

Test 1: Into vials with septa. If no pressure is built up, the blockage during extraction was caused by the cell containing the sample. If pressure builds up, a part inside the SpeedExtractor is blocked. Release the pressure manually and continue with test 2.

Test 2: Into vial without septa. If no pressure is built up, the blockage is located between the vial and exhaust. The following parts can be blocked: needles, tube from needle to exhaust, or exhaust tube outside the unit. The needles or the exhaust tube outside the SpeedExtractor can be exchanged following the instruction in section 7.2.3. The tube from the needle to the exhaust must be exchanged or cleaned by a service technician. A leak test must be carried out to ensure the tightness of the SpeedExtractor.

If pressure builds up, a part inside the SpeedExtractor is blocked. Release the pressure manually and continue with test 3.

Test 3: Into waste. If no pressure built up, the blockage is located between outlet valve and vial. The following parts can be blocked: outlet valve, capillaries, needles. The needles can be exchanged by the operator (see section 7.2.3). The outlet valve and the capillaries must be exchanged or cleaned by a service technician. A leak test must be carried out to ensure the tightness of the SpeedExtractor.

If pressure builds up, a part inside the SpeedExtractor is blocked. Release the pressure manually and continue with test 4.



Test 4: Heater in the back position, beaker underneath. If no pressure is built up, the blockage is located between lower seal holder and outlet valve. The following parts can be blocked: lower seal holder, cooling unit, capillary, outlet valve. These parts must be exchanged or cleaned by a service technician. A leak test must be carried out to ensure the tightness of the SpeedExtractor.

If pressure builds up, the top cover plate or the parts up to the solvent valve are blocked. Release the pressure manually. The top cover plate can be exchanged or cleaned by the operator. If parts before the top cover plate are blocked the service technician has to exchange or clean these parts.

Go back to the SERVICE FUNCTIONS with the left arrow.

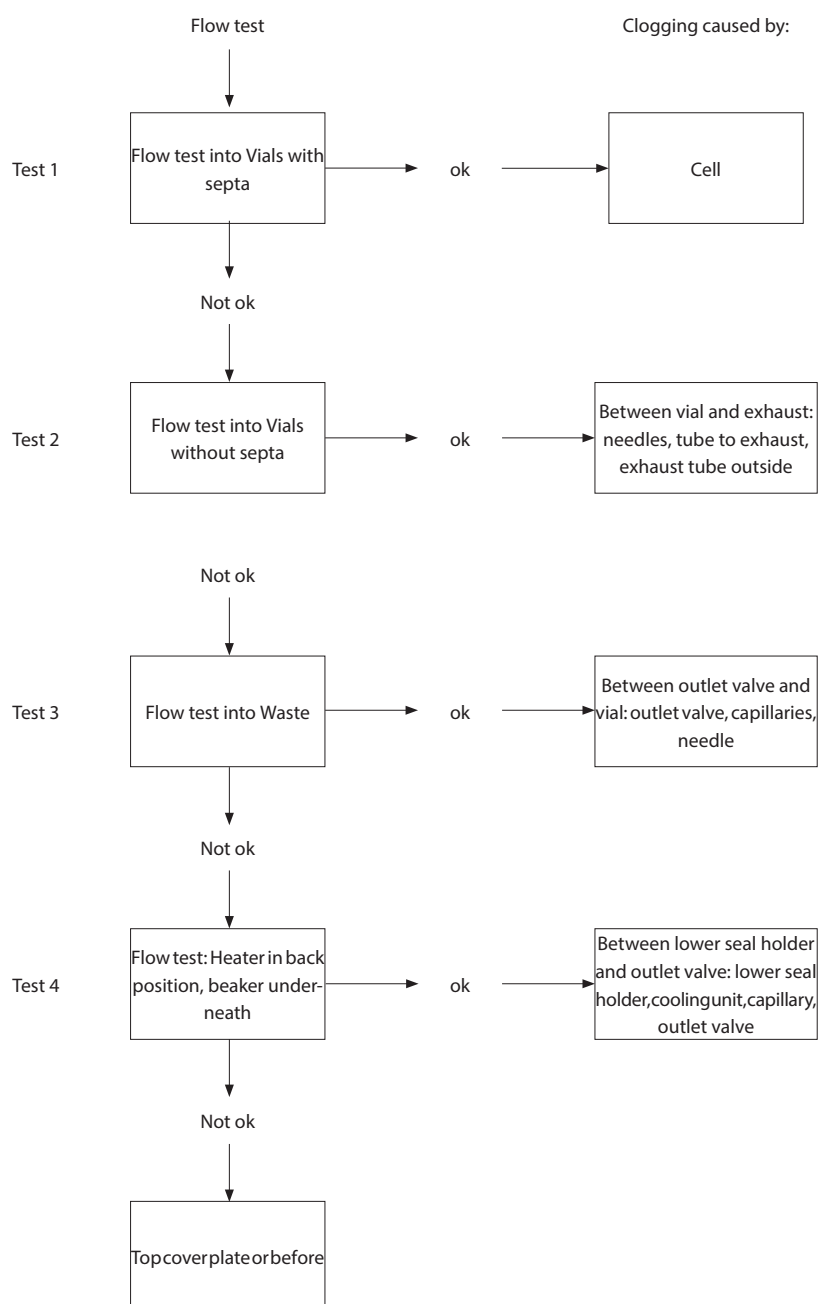

8.2.5 Moving the cell and vial lift

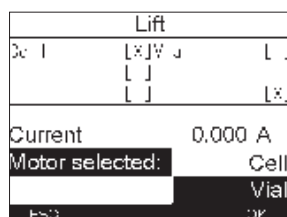

Go to SERVICE FUNCTIONS → LIFT. The position of the lift for the heating block (CELL) and the collection rack (VIAL) is shown by crossed brackets [X]. Select the CELL or VIAL lift using the selection knob and press UP or DOWN to move the lift. Press stop to STOP movement. The changes in the position are shown by light barriers (open [] or crossed [X] brackets). The current entry is an indication of possible blockage of the lift. Go back to the SERVICE FUNCTIONS with the left arrow.

8.2.6 Changing the fan performance

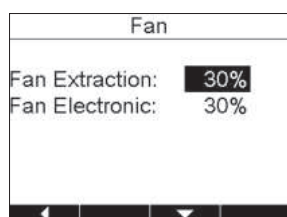

Go to SERVICE FUNCTIONS → FAN. The performance of the internal fan is set to 30 % for normal operation. In case of a fault event the performance is set to 100 % to get rid of any solvent possibly leaking from the system.

NOTE

It is not advisable to change this setting as it has an impact on the actual temperature of the heating block.

Go back to the SERVICE FUNCTIONS with the left arrow.

8.2.7 Displaying the operating hours

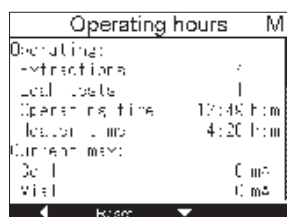

Go to SERVICE FUNCTIONS → OPERATING HOURS. The number of extractions and leak tests as well as the operating hours of the instrument and the heater are listed. Further information like highest achieved temperature or pressure is also shown. This information is particularly important for the service technician. Go back to the SERVICE FUNCTIONS with the left arrow.

8.2.8 Unit information

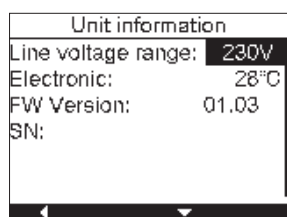

Go to SERVICE FUNCTIONS → UNIT INFORMATION. The unit information submenu contains specifications of the instrument and certain components such as serial number (SN) and firm-ware version (FW) which are helpful in case of troubleshooting. Go back to the SERVICE FUNCTIONS with the left arrow.

8.3 Customer service

Only authorized service personnel are allowed to perform repair work on the instrument. These persons have comprehensive technical training and knowledge of the possible dangers that can arise from the instrument.

Contacts for official BUCHI customer service offices are provided on the BUCHI website at: www.buchi.com. If your instrument malfunctions or you have technical questions or application problems, please contact one of these offices.

Customer service offers the following:



- Spare part delivery
- Repairs
- Technical advice

9 Shutdown, storage, transport and disposal

This chapter instructs how to shut down and to pack the instrument for storage or transport. Specifications for storage and shipping conditions can also be found listed here.

9.1 Storage and transport

Switch off the instrument and remove the power cord. To disassemble the SpeedExtractor follow the installation instructions in section 5 in reverse order. Remove all liquids and dusty and hazardous residues before packaging the instrument.

	<p>! WARNING</p> <p>Death or serious poisoning by contact or incorporation of harmful substances.</p> <ul style="list-style-type: none"> • Wear safety goggles • Wear safety gloves • Wear a laboratory coat • Flush the instrument and clean all accessories thoroughly to remove possibly dangerous substances • Do not clean dusty parts with compressed air • Store the instrument and its accessories at a dry place in its original packaging
	<p>! CAUTION</p> <p>Risk of minor or moderate injury by heavy weight of the instrument.</p> <ul style="list-style-type: none"> • Consult three further persons to transport the instrument • Do not drop the instrument or its transport box • Place the instrument on a stable, even and vibration-free surface • Keep limbs out of crushing zone

9.2 Disposal

For instrument disposal in an environmentally friendly manner, a list of materials is given in chapter 3.3. This helps to ensure that the components can be separated and recycled correctly by a specialist for disposal.

For disposal of liquids and consumables such as catalyst or acid, see data sheets of these chemicals.

Follow valid regional and local laws concerning disposal. For help, please contact the local authorities.

NOTE

When returning the instrument to the manufacturer for repair work, please copy and complete the health and safety clearance form on the following page and enclose it with the instrument.

9.3 Health and safety clearance

Health and Safety Clearance

Declaration concerning safety, potential hazards and safe disposal of waste.

For the safety and health of our staff, laws and regulations regarding the handling of dangerous goods, occupational health and safety regulations, safety at work laws and regulations regarding safe disposal of waste, e.g. chemical waste, chemical residue or solvent, require that this form must be duly completed and signed when equipment or defective parts were delivered to our premises.

Instruments or parts will not be accepted if this declaration is not present.

Equipment

Model:

Part/Instrument no.:

1.A Declaration for non dangerous goods

We assure that the returned equipment

- has not been used in the laboratory and is new
- was not in contact with toxic, corrosive, biologically active, explosive, radioactive or other dangerous matters.
- is free of contamination. The solvents or residues of pumped media have been drained.

1.B Declaration for dangerous goods

List of dangerous substances in contact with the equipment:

Chemical, substance	Danger classification

We assure for the returned equipment that

- all substances, toxic, corrosive, biologically active, explosive, radioactive or dangerous in any way which have pumped or been in contact with the equipment are listed above.
- the equipment has been cleaned, decontaminated, sterilized inside and outside and all inlet and outlet ports of the equipment have been sealed.

2. Final Declaration

We hereby declare that

- we know all about the substances which have been in contact with the equipment and all questions have been answered correctly
- we have taken all measures to prevent any potential risks with the delivered equipment.

Company name or stamp: _____

Place, date: _____

Name (print), job title (print): _____

Signature: _____

10 Spare parts

This chapter lists spare parts and optional extras, including all of the relevant order information for ordering from BUCHI. Always indicate the product designation and part number when ordering any spare parts. Use only genuine BUCHI consumables and spare parts for maintenance and repair, in order to ensure optimum system performance and reliability. Prior written permission of the manufacturer should be obtained before any modifications are made to the spare parts used.

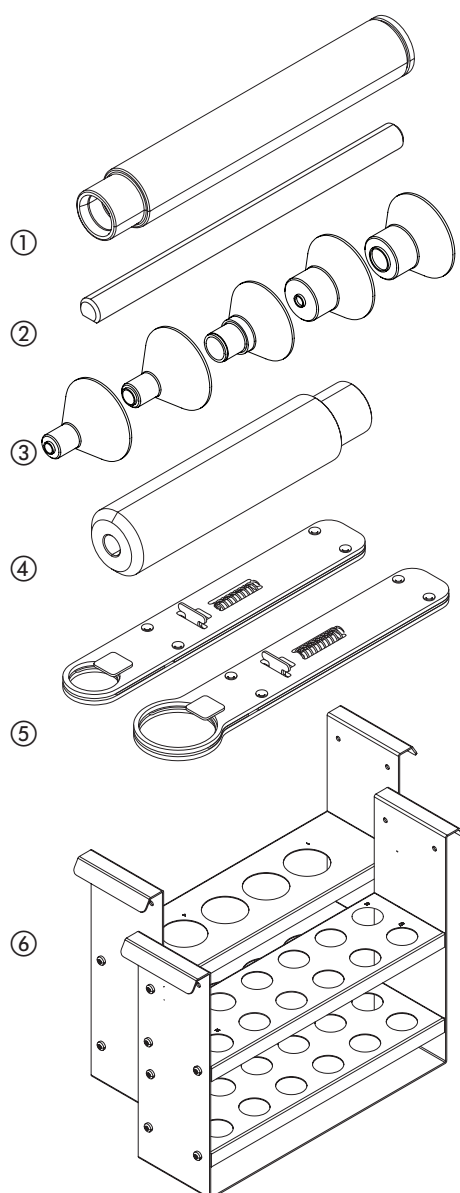

Accessories related to the extraction cell

Item	Order no
① Extraction cell E-916, 10 mL	051237
Extraction cell E-916, 20 mL	051236
Extraction cell E-916, 40 mL	051235
Extraction cell E-916XL, 60ml	11069535
Extraction cell E-914, 10 mL*	11067988
Extraction cell E-914, 20 mL*	11067989
Extraction cell E-914, 40 mL	051234
Extraction cell E-914, 80 mL	051233
Extraction cell E-914, 120 mL	051232
② Expansion element, 2 mL	053708
Expansion element, 10 mL	053359
Expansion element, 20 mL	053358
Expansion element, 40 mL	053357
Expansion element, 80 mL	053356
Expansion element, 120 mL	053355
③ Funnel E-916, 10 mL	053035
Funnel E-916, 20 mL	053396
Funnel E-916, 40 mL	053397
Funnel E-916XL, 60ml	11069529
Funnel E-914, 10 - 20 mL	11067712
Funnel E-914, 40 - 120 mL	053036
④ Plunger E-916	053037
Plunger E-916XL	11069530
Plunger E-914	053038
⑤ Extraction cell gripper E-916	053030
Extraction cell gripper E-916XL	11069534
Extraction cell gripper E-914	053026
⑥ Extraction cell rack E-916	053690
Extraction cell rack E-916XL	11069547
Extraction cell rack E-914	053691
Extruder rod	11055284

*Only Firmware Version 1.05 or higher

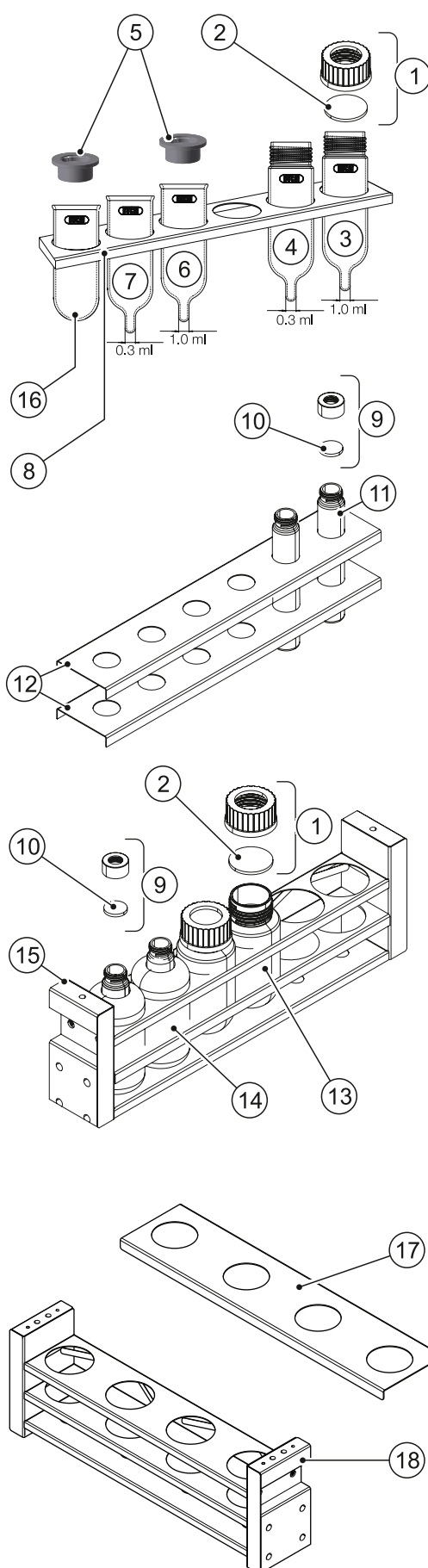

Accessories related to the standard collection unit

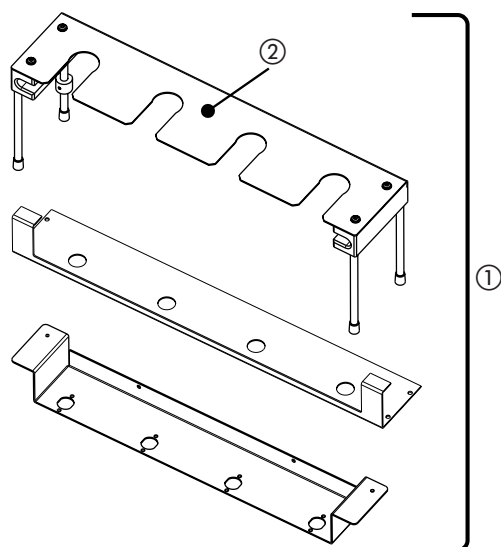
Item	PU	Order no.
① Caps and septa for wide-necked vial, GL 45 thread	12	11056528
② Septa for wide-necked vials	12	053677
③ Analyst vessel, 1.0 mL appendix, GL 45 thread	12	11056498
③ Analyst vessel, 1.0 mL appendix, GL 45 thread, amber glass	12	11056910
④ Analyst vessel, 0.3 mL appendix, GL 45 thread	12	11056499
④ Analyst vessel, 0.3 mL appendix, GL 45 thread, amber glass	12	11056911
⑤ PP plugs OD 43 mm	100	11055713
⑥ Analyst vessel, 1.0 mL appendix	12	046015
⑦ Analyst vessel, 0.3 mL appendix	12	046016
⑧ Retaining plate for Syncore Analyst vessels for E-916	1	11057054
⑬ Polyvap vessel wide necked	12	040907
⑨ Caps and septa for narrow-necked vials	100	11056535
⑩ Septa for narrow-necked vials	100	049536
⑪ Collection vials, 60 mL	72	049535
⑫ Retaining plate E-914 for 60 mL vials	2	11055205
Retaining plate E-914 for 60 mL vials	2	11059365
① Caps and septa for wide-necked vial, GL 45 thread	12	11056528
② Septa for wide-necked vials	12	053677
⑬ Collection vials, wide-necked (GL 45), round bottom, 220 mL	6	053208
⑨ Caps and septa for narrow-necked vials	100	11056535
⑩ Septa for narrow-necked vials	100	049536
⑭ Collection vials, narrow-necked, flat bottom, 240 mL	6	052672
⑮ Collection unit for E-916	1	053698
⑰ Retaining plate for Syncore Analyst R-12 vessels, for E-914	1	11058339
⑱ Collection unit E-914	1	11058332

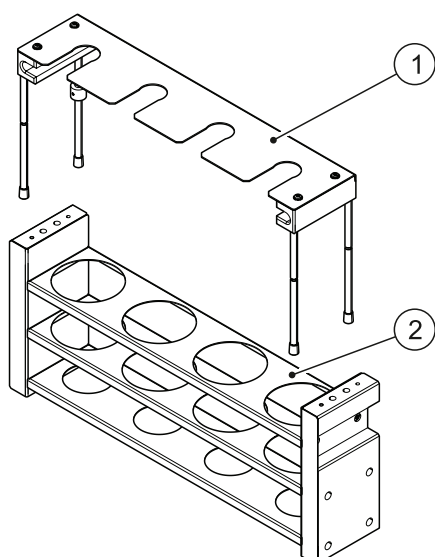
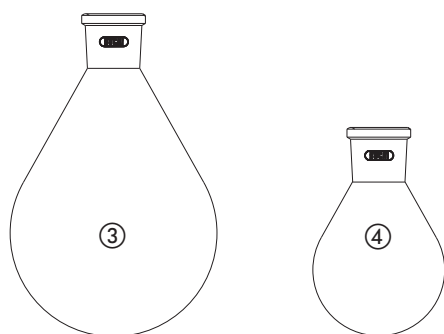

Accessories related to the flask collection unit (only for E-914)

Item	PU	Order no.
① Conversion kit for the flask collection unit	1	11056130
② Flask collection unit	1	11056043
③ 500 mL round bottom flask with 29.2/32 flange	1	000434
④ 250 mL round bottom flask with 29.2/32 flange	1	000433



Accessories related to the SpeedExtractor E-914, mounted on the pedestal

Item	PU	Order no.
① Flask collection unit for longer flasks, e.g. pear flasks	1	11058527
② Polyvap R-6 collection unit	1	11058528

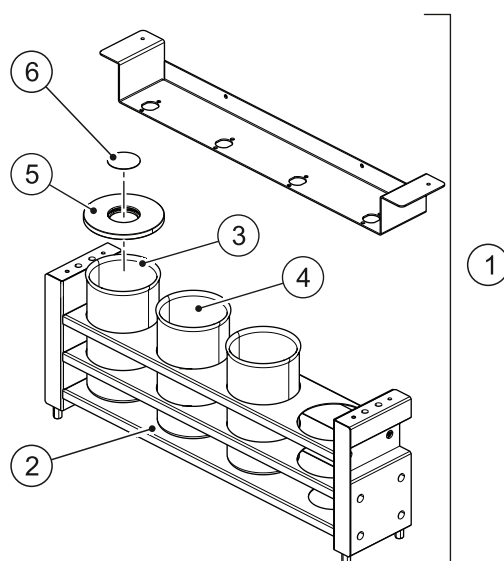

Accessories related to the Syncore® Analyst R-6 collection unit (only for E-914)

Item	PU	Order no.
① Conversion kit for R-6 collection unit	1	11058211
② Analyst R-6 collection unit	1	11058344
③ R-6 vessel, 1.0 mL appendix	6	038569
④ R-6 vessel, 0.3 mL appendix	6	038485
⑤ Cover for R-6 vessels, PTFE	4	11058655
⑥ Septa for cover for R-6 vessels, PTFE	100	11058656



Accessories related to waste/solvent bottles

Item	PU	Order no.
① Safety cap for waste bottle, 7-port	1	11056948
② Safety cap, 2-port	1	11056949
③ Solvent bottle with GL 45 cap	1	053203

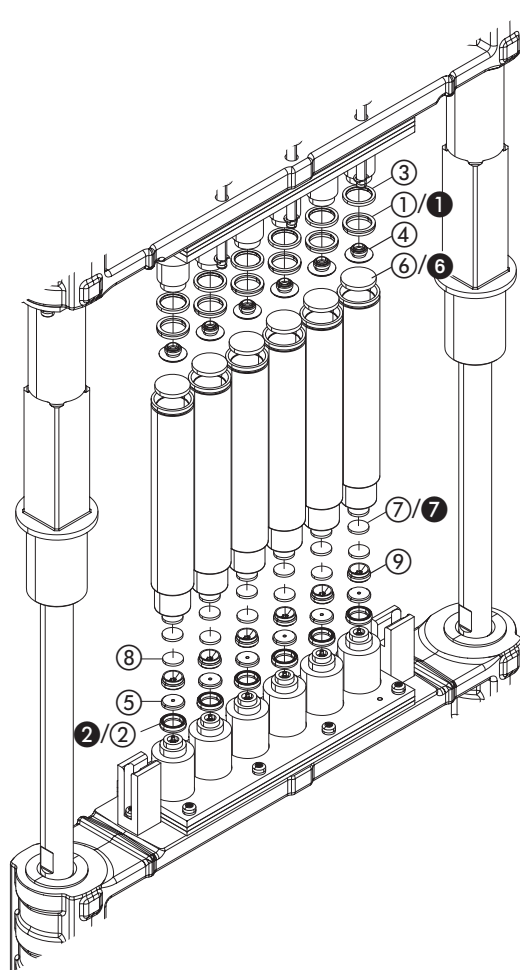

Accessories related to the extraction cell

Item	PU	Order no.
① Top cup seals for E-916, PTFE	12	053669
① Top cup seals for E-916XL, PTFE	12	11069763
① Top cup seals for E-916, PE*	12	11056106
① Top cup seals for E-914, PTFE	12	053671
① Top cup seals for E-914, PE*	12	11056108
② Bottom cup seals, PTFE	12	053670
② Bottom cup seals, PE*	12	1156107
③ Supporting ring, PEEK for E-916	2	053666
③ Supporting ring, PEEK for E-916XL	2	11069769
③ Supporting ring, PEEK for E-914	2	053667
④ Top cover plates for E-916	2	053672
④ Top cover plates for E-916XL	2	11069777
④ Top cover plates for E-914	2	053673
⑤ Bottom cover plates for E-916/E-914	2	053674
⑥ Top filter for E-916, cellulose	100	049572
⑥ Top filter for E-916XL, cellulose	100	11069533
⑥ Top filter for E-914, cellulose	100	051249
⑥ Top filter for E-916, glass fiber	100	11057189
⑥ Top filter for E-914, glass fiber	100	11057190
⑦ Bottom filter for E-916 / E-914, cellulose	100	049569
⑦ Bottom filter for E-916 / E-914, glass fiber	100	11055932
⑧ Metal frit	25	049568
⑨ Plug screw	2	053209

* The instrument is equipped with PTFE seals by default. The corresponding PE seals are optionally available as accessory (max. temperature 100 °C).



Disposables

Item	PU	Order no.
Extractionthimble,cellulose,40mL	25	11055334
Extractionthimble,cellulose,80mL	25	11059610
Extraction thimble, cellulose, 120 mL	25	11055358
Extraction thimble, glass fiber, 40 mL	25	11056633
Extraction thimble, glass fiber, 80 mL	25	11059612
Extraction thimble, glass fiber, 120 mL	25	11059611



Disposables

Item	PU	Order no.
Weighing boat	250	053202



① Quartz sand, dried at 750°C	2.5kg	037689
② Diatomaceous earth	1.0 kg	053201

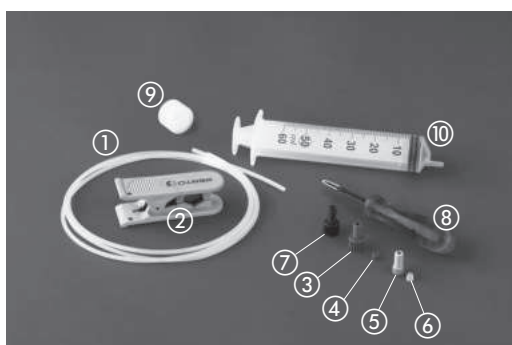

Accessories related to tubing, fittings

Item	PU	Order no.
① Solvent inlet, exhaust tube, FEP, OD 1/8"	5 m	11055604
① Waste outlet tube, FEP, OD 1/16", 0.5 m	1	053303
② Tube cutter	1	019830
③ 1/4 UNF-28 fitting 1/8", green	10	053663
④ 1/4 UNF-28 ferrules 1/8", green	10	053664
⑤ 1/4 UNF-28 fitting 1/16", gray	25	044816
⑥ 1/4 UNF-28 ferrules 1/16", gray	25	044269
⑦ 1/4 UNF-28 blind fitting 1/8", blue	10	053665
⑧ Fitting removal tool	1	054400
⑨ Intake filter	1	044340
⑩ Luer tipped syringe (50 mL)	1	034882
(Extraction) Needles	12	053675
Swagelokbrassnutandferrule 1/8"	1	11055342

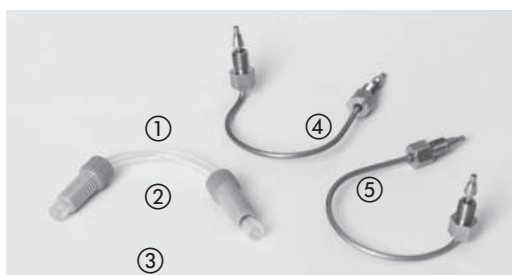

Accessories related to the pump

Item	PU	Order no.
① Suction tube, FEP, OD 1/8"	5 m	11055604
② 1/4 UNF-28 fitting 1/8", green	10	053663
③ 1/4 UNF-28 ferrules, green	10	053664
④ Outlet capillary, metal, left*	1	053613
⑤ Outlet capillary, metal, right*	1	053614

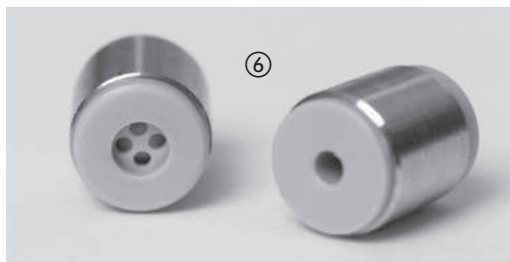

Accessories related to the pump

Item	PU	Order no.
⑥ Check valves	1	053610
Piston seal, black, PTFE	1	053612
Piston seal, white	1	11056588

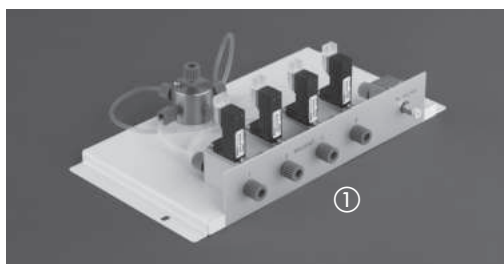

Further accessories

Item	PU	Order no.
① 4 port solvent mixer*		053381
② Small cooling unit for viscous samples*		053682

*Technician required for installation.

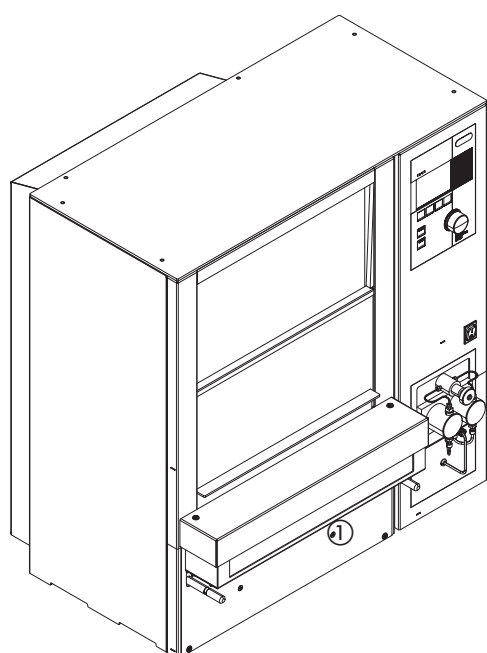
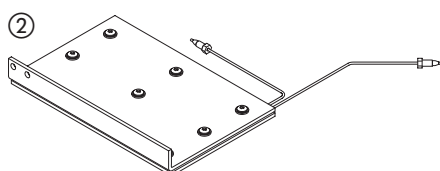

Housing

Item	PU	Order no.
① Covering glass needle assembly		051322



Accessories related with the process workflow evaporation to dryness

Item	PU	Order no.
6 port parallel evaporator, Multi-vapor™P-6 with inert membrane pump, 220–240 V	1	MP21199S22
6 port parallel evaporator, Multi-vapor™P-6 with inert membrane pump, 100–120 V	1	MP22199S22
Sealing adapters for 60 mL vials	6	049692
Sealing adapters for 220 mL vials	6	049761
Sealing adapters for 240 mL vials	6	049716
Blank adapters	6	049729
Vacuum membrane pump (1.8 m ³ /h, <10 mbar) with professional vacuum controller, Woulff bottle and sec. condenser	1	071311
Recirculating Chiller F-105, 230 V	1	11056462
Recirculating Chiller F-105, 115 V		11056463
Recirculating Chiller F-108, 230 V	1	11056464
Recirculating Chiller F-108, 115 V		11056465

Accessories related with the process workflow – evaporation to defined residual volumes

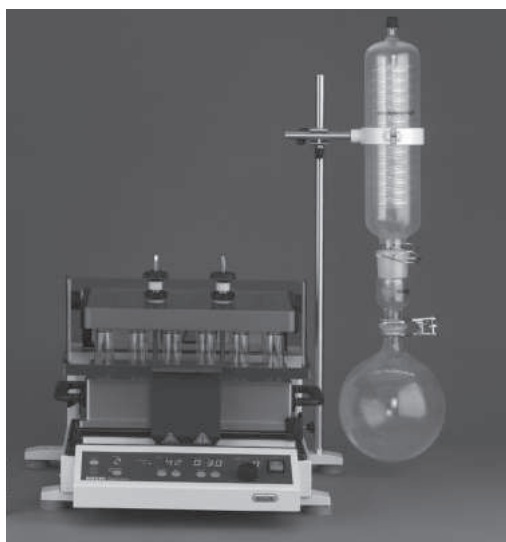

Item	PU	Order no.
12 port parallel evaporator, Syncore® Analyst R-12, 100 V	1	1A1S231N0
12 port parallel evaporator, Syncore® Analyst R-12, 120 V	1	1A2S231N0
12 port parallel evaporator, Syncore® Analyst R-12, 230 V	1	1A3S231N0
Syncore® Analyst R-6, 100 V	1	1A1S221N0
Syncore® Analyst R-6, 120 V	1	1A2S221N0
Syncore® Analyst R-6, 230 V	1	1A3S221N0
Vacuum membrane pump (1.8 m ³ /h, <10 mbar) with professional vacuum controller, Woulff bottle and sec. condenser	1	071311
Recirculating Chiller F-105, 230 V	1	11056462
Recirculating Chiller F-105, 115 V		11056463
Recirculating Chiller F-108, 230 V	1	11056464
Recirculating Chiller F-108, 115 V		11056465

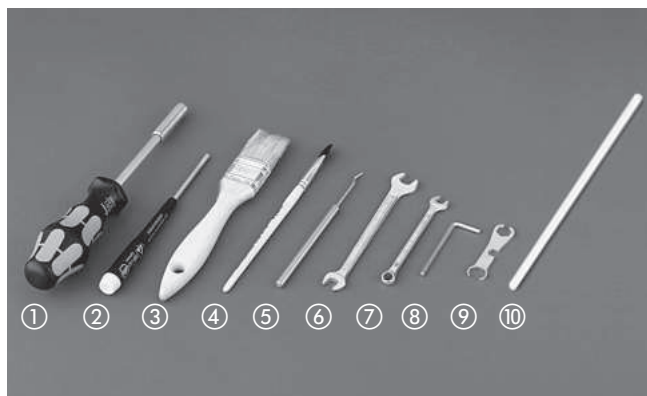

Tools

Item	PU	Order no.
① Bit wrench	1	052783
② Torx screwdriver TX20	1	053668
③ Brush large	1	053257
④ Brush small	1	053256
⑤ Filter hook	1	053316
⑥ Spannerwrench 8/10mm	1	053608
⑦ Spanner wrench ¼"	1	053204
⑧ Allen wrench 3 mm	1	000610
⑨ Turix wrench	1	044349
⑩ Extruder rod	1	11055284

Documents

Product	Qty	Order no.	Product	Qty	Order no.
IQ/OQ reference set, EN	1	11055354	Operation manual, EN	1	093218
IQ/OQ documentation, EN	1	11056092	Operation manual, GE	1	093219
Repeating OQ	1	11056093	Operation manual, FR	1	093220
SpeedExtractorApplicationBooklet	1	11593333	Operation manual, IT	1	093221
Product CD	1	092202	Operation manual, ES	1	093222
SpeedExtractor Quick Guide	1	093286			

Software

Product	Qty	Order no.	Product	Qty	Order no.
SpeedExtractor Record, demo license	1	053074	Operation manual, software, EN	PDF	incl.onCD
SpeedExtractor Record license	1	053073	USB cable 2.0 A-B, 4.5 m	1	049226

11 Declarations and requirements

11.1 FCC requirements (for USA and Canada)

English:

This equipment has been tested and found to comply with the limits for a Class A digital device, pursuant to both Part 15 of the FCC Rules and the radio interference regulations of the Canadian Department of Communications. These limits are designed to provide reasonable protection against harmful interference when the equipment is operated in a commercial environment.

This equipment generates, uses, and can radiate radio frequency energy and, if not installed and used in accordance with the instruction manual, may cause harmful interference to radio communications. Operation of this equipment in a residential area is likely to cause harmful interference, in which case the user will be required to correct the interference at his or her own expense.

Français:

Cet appareil a été testé et s'est avéré conforme aux limites prévues pour les appareils numériques de classe A et à la partie 15 des réglementations FCC ainsi qu'à la réglementation des interférences radio du Canadian Department of Communications. Ces limites sont destinées à fournir une protection adéquate contre les interférences néfastes lorsque l'appareil est utilisé dans un environnement commercial.

Cet appareil génère, utilise et peut irradier une énergie à fréquence radioélectrique, il est en outre susceptible d'engendrer des interférences avec les communications radio, s'il n'est pas installé et utilisé conformément aux instructions du manuel d'instructions. L'utilisation de cet appareil dans les zones résidentielles peut causer des interférences néfastes, auquel cas l'utilisateur sera amené à prendre les dispositions utiles pour palier aux interférences à ses propres frais.

BÜCHI Tochtergesellschaften:

Europa

Schweiz/Österreich

BÜCHI Labortechnik AG
 CH – 9230 Flawil
 T +41 71 394 63 63
 F +41 71 394 64 64
 buchi@buchi.com
 www.buchi.com

Benelux

BÜCHI Labortechnik GmbH
 Branch Office Benelux
 NL – 3342 GT Hendrik-Ido-Ambacht
 T +31 78 684 94 29
 F +31 78 684 94 30
 benelux@buchi.com
 www.buchi.com /bx-en

Frankreich

BUCHI Sarl
 FR – 94656 Rungis Cedex
 T +33 1 56 70 62 50
 F +33 1 46 86 00 31
 france@buchi.com
 www.buchi.com/fr-fr

Deutschland

BÜCHI Labortechnik GmbH
 DE – 45127 Essen
 T +800 414 0 414 0
 T +49 201 747 490
 F +49 201 747 492 0
 deutschland@buchi.com
 www.buchi.com/de-de

Italien

BUCHI Italia s.r.l.
 IT – 20010 Cornaredo (MI)
 T +39 02 824 50 11
 F +39 02 57 51 28 55
 italia@buchi.com
 www.buchi.com/it-it

Russland

BUCHI Russia/CIS
 Russia 127287 Moscow
 T +7 495 36 36 495
 russia@buchi.com
 www.buchi.com/ru-ru

Grossbritannien

BUCHI UK Ltd.
 GB – Oldham OL9 9QL
 T +44 161 633 1000
 F +44 161 633 1007
 uk@buchi.com
 www.buchi.com/gb-en

Deutschland

BÜCHI NIR-Online
 DE – 69190 Walldorf
 T +49 6227 73 26 60
 F +49 6227 73 26 70
 nir-online@buchi.com
 www.nir-online.de

Amerika

Brasilien

BUCHI Brasil Ltda.
 BR – Valinhos SP 13271-570
 T +55 19 3849 1201
 F +55 19 3849 2907
 brasil@buchi.com
 www.buchi.com/br-pt

USA/Kanada

BUCHI Corporation
 US – New Castle, DE 19720
 T +1 877 692 8244 (Toll Free)
 T +1 302 652 3000
 F +1 302 652 8777
 us-sales@buchi.com
 www.buchi.com/us-en

Asien

China

BUCHI China
 CN – 200233 Shanghai
 T +86 21 6280 3366
 F +86 21 5230 8821
 china@buchi.com
 www.buchi.com/cn-zh

Indien

BUCHI India Private Ltd.
 IN – Mumbai 400 055
 T +91 22 667 75400
 F +91 22 667 18986
 india@buchi.com
 www.buchi.com/in-en

Indonesien

PT. BUCHI Indonesia
 ID – Tangerang 15321
 T +62 21 537 62 16
 F +62 21 537 62 17
 indonesia@buchi.com
 www.buchi.com/id-in

Japan

Nihon BUCHI K.K.
 JP – Tokyo 110-0008
 T +81 3 3821 4777
 F +81 3 3821 4555
 nihon@buchi.com
 www.buchi.com/jp-ja

Korea

BUCHI Korea Inc.
 KR – Seoul 153-782
 T +82 2 6718 7500
 F +82 2 6718 7599
 korea@buchi.com
 www.buchi.com/kr-ko

Malaysia

BUCHI Malaysia Sdn. Bhd.
 MY – 47301 Petaling Jaya,
 Selangor
 T +60 3 7832 0310
 F +60 3 7832 0309
 malaysia@buchi.com
 www.buchi.com/my-en

Singapur

BUCHI Singapore Pte. Ltd.
 SG – Singapore 609919
 T +65 6565 1175
 F +65 6566 7047
 singapore@buchi.com
 www.buchi.com/sg-en

Thailand

BUCHI (Thailand) Ltd.
 TH – Bangkok 10600
 T +66 2 862 08 51
 F +66 2 862 08 54
 thailand@buchi.com
 www.buchi.com/th-th

BÜCHI Support-Center:

Südostasien

BUCHI (Thailand) Ltd.
 TH-Bangkok 10600
 T +66 2 862 08 51
 F +66 2 862 08 54
 bacc@buchi.com
 www.buchi.com/th-th

Naher Osten

BÜCHI Labortechnik AG
 UAE – Dubai
 T +971 4 313 2860
 F +971 4 313 2861
 middleeast@buchi.com
 www.buchi.com

Lateinamerika

BUCHI Latinoamérica S. de R.L. de C.V.
 MX – Mexico City
 T +52 55 9001 5386
 latinoamerica@buchi.com
 www.buchi.com/es-es

Wir werden weltweit von mehr als 100 Vertriebspartnern vertreten.
 Ihren Händler vor Ort finden Sie unter: www.buchi.com