

BROOKFIELD CAP 2000+ VISCOMETER

MODEL CAP 2000+

Operating Instructions

Manual No. **M02-313B0707**



SPECIALISTS IN THE
MEASUREMENT AND
CONTROL OF VISCOSITY

with offices in: Boston • Chicago • London • Stuttgart • Guangzhou

BROOKFIELD ENGINEERING LABORATORIES, INC.
11 Commerce Boulevard, Middleboro, MA 02346 USA
TEL 508-946-6200 or **800-628-8139** (USA excluding MA)
FAX 508-946-6262 INTERNET <http://www.brookfieldengineering.com>



LAB Online Exhibition



ADDENDUM TO

BROOKFIELD CAP 2000+ Operating Instructions Manual No. **M02-313B** Addendum No. **D07-347**

This document is referred to as Appendix B on page 25 in the CAP 2000+ Manual, but has accidentally been left out of the document.

COMMUNICATIONS

Printer Output - CAP 2000+

The cable connection on the CAP 2000+ Viscometer is a standard 25 pin parallel printer cable connector.

RS 232 Output - CAP 2000+

When connecting the CAP 2000+ to a computer, use Brookfield Computer Cable (Part No. DVP-80). If you are *not using* the Brookfield computer cable, jump (connect) pins 4 and 9 (refer to **Figure 1**) on the CAP 2000 end of the serial cable. The cable connections are:

Com Port RxD (pin 2 (9 pin) or pin 3 (25 pin) to CAP Txd (pin 3)
Com Port TxD (pin 3 (9 pin) or pin 2 (25 pin) to CAP RxD (pin 2)
Com Port ground (pin 7) to CAP Serial Ground (pin 5)

The RS232 protocol is implemented as follows:

Baud rate: 9600
Parity: None
Data bits: 8
Stop bits: 1

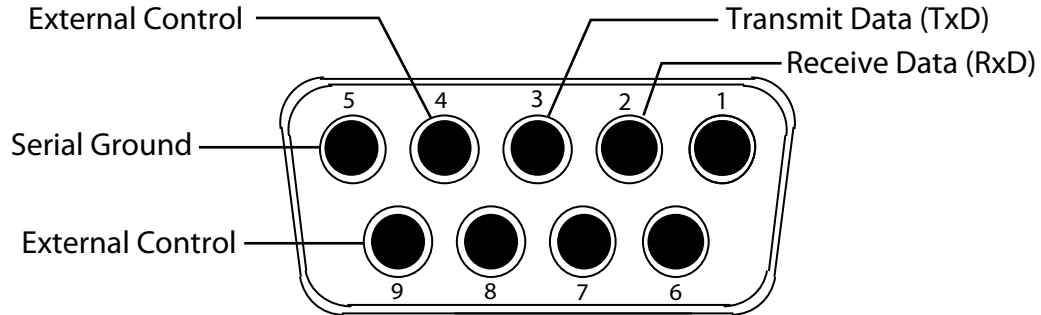

No Connection to Pin 1

Figure 1

The following pages review the transmit/receive commands between the CAP 2000+ and a computer (Table 2), the byte status interpretation (Table 1) and a sample program for external control of the CAP 2000+ Viscometer.

CAP 2000+ TRANSMIT/RECEIVE COMMANDS FOR COMPUTER COMMUNICATION

COMMAND RECEIVED	CAP 2000 RESPONSE	FUNCTION
Vyyy<CR>	V<SS><CR>	<ul style="list-style-type: none"> • Sets current speed and starts motor. • 000H <=yyy <=3E8H (t to 1000 RPM). • Anything between 001H and 005H is interpreted as 5 RPM. • Anything over 3E8H is interpreted as 1000 RPM. • All yyy values shall be padded to 3 characters with leading zeros. • A speed of 000 will stop the motor. • Sets or clears the motor on bit (bit 1) in the status byte accordingly. • Sets illegal value bit in status byte if yyy is outside limits (See Table 2).
Tttt<CR>	T<ss><CR>	<ul style="list-style-type: none"> • Sets current temperature and controls to it. • 032H <= ttt <= 2EEH; CAPLO (5°C to 75°C). • 000H <= ttt <= 92EH; CAPHI (0°C to 235°C). • Any temperature under the lower limit is interpreted as the lower limit. • Any temperature over the upper limit is interpreted as the upper limit. • The CAP 2000+ must divide all ttt values received by 10 before use. • All ttt values shall be padded to 3 characters with leading zeros. • Sets illegal value bit in status byte if ttt is outside limits (See Table 2).
R<CR>	R<vvvvvvffffrrrrrttcc> <ss><CR>	<ul style="list-style-type: none"> • Returns a data packet to the host. • vvvvvv : viscosity ,P, (multiplied by 1000 by the CAP 2000+). All vvvvvv values shall be padded to 6 characters with leading zeros. • ffff: FSR ,%, (multiplied by 100 by the CAP 2000+). All ffff values shall be padded to 4 characters with leading zeros. • rrrrrr : shear rate , 1/seconds, (multiplied by 100 by the CAP 2000+). All rrrrrr values shall be padded to 6 characters with leading zeros. • ttt : temperature ,°C, (multiplied by 10 by the CAP 2000+). All ttt values shall be padded to 3 characters with leading zeros. • cc : cone. All cc values shall be padded to 2 characters with leading zeros.
I<CR>	ICAP+<bbxxdddd <ss><CR>	<ul style="list-style-type: none"> • Identify the viscometer and firmware in use. • bb: HI or LO : temperature range. • xxx : firmware version (decimal format) multiplied by 100. • dddd : spring constant, (multiplied by 10,000 by the CAP 2000+). All dddd values shall be padded to characters with leading zeros.

Scc<CR>	Saaaaaececc <ss><CR>	<ul style="list-style-type: none"> • Selects cone to be used. • cc : cone #: All cc values shall be padded to 2 characters with leading zeros. • 01H<=cc<=14H; Any S command sent with a cone number outside these limits will be ignored. • Cone # outside limits: response values represent the cone the instrument is staying with. • aaaaaa : cone multiplier constant. All aaaaaa values shall be padded to 6 characters with leading zeros. • eeeee : shear rate constant of cone (multiplied by 10000). All eeeee values shall be padded to 6 characters with leading zeros. • Sets illegal value bit in status byte if cc is outside limits (See Table 2).
Kccvvvvveeeeee aaaaaayyy<CR>	Kccvvvvveeeeee aaaaaayyy<ss><CR>	<ul style="list-style-type: none"> • Calibrate a new cone. • The response will not be returned to the host until the calibration is complete. • cc : cone #: All cc values shall be padded to 2 characters with leading zeros. • vvvvvv : viscosity of calibration fluid (centipoise). All vvvvvv values shall be padded to 6 characters with leading zeros. • eeeee : shear rate constant of cone. The CAP 2000+ divides all eeeee values by 10000 upon receiving them and multiplies by 10000 before sending them. All eeeee values shall be padded to 6 characters with leading zeros. • aaaaaa : cone multiplier constant. All aaaaaa values shall be padded to 6 characters with leading zeros. • yyy : calibration speed. Subject to same limitations as in V command. • If there is an error, bit 7 of the status byte is set.
Invalid Command	??<CR>	<ul style="list-style-type: none"> • Invalid command received

Table 1

Note: All multiplication and division operations performed on any of the command values should be done while the values in question are in their decimal (base 10) form (i.e. before any conversion to hexadecimal).

LEGEND	
Command	Description
<aaaaaa>	Cone multiplier constant (hexadecimal). All cone multiplier constant values are six characters padded with leading zeros.
<bb>	(HI / LO) Indicates whether the instrument operates in the high (0°C to 235°C) temperature range or the low (5°C to 75°C) temperature range.
<cc>	Cone number (hexadecimal); all cone number are two characters padded with leading zeroes. All cone values are two characters padded with leading zeroes.
<CR>	Carriage return
<dddd>	Spring Constant (hexadecimal). The Spring Constant must be multiplied by 10,000 before transmission by the CAP 2000+. Use the base Spring Constant for the model, not an adjusted constant after calibrating.
<eeeeee>	Shear rate constant of a cone to be calibrated (hexadecimal). The CAP 2000+ must divide shear rate constants by 10000 after they are received, and multiply shear rate constants by 10000 before sending them out. All shear rate constant values are six characters padded with leading zeroes.
<ffff>	% FSR (hexadecimal). % FSR values are multiplied by 100 before transmission from the CAP 2000+. All FSR values are four characters padded with leading zeroes.
<rrrrrr>	Shear rate (1/seconds) values (hexadecimal). Shear rate values are multiplied by 100 before transmission by the CAP 2000+. All shear rate values are six characters padded with leading zeroes.
<ss>	Status byte, returned in hexadecimal format, see Table 2 for complete description. All status bytes are two characters padded with leading zeroes.

<tt>	Temperature (°C) sent to or from the CAP 2000+ (hexadecimal). The CAP 2000+ must divide all temperature values received by 10, and multiply all temperature values sent by 10. All temperature inputs are three characters padded with leading zeroes.
<vvvvvv>	Viscosity (P) sent to or from the CAP 2000+ (hexadecimal). The CAP 2000+ must divide all viscosity values received by 1000, and multiply all viscosity values sent by 1000; all viscosity values are six characters padded with leading zeroes.
<xxx>	Firmware version number, in decimal format, multiplied by 100 by CAP 2000+ before transmission (i.e. for firmware version 2.15, xxx would be 215).
<yyy>	Speed (RPM) input (hexadecimal). All speeds are three characters padded with leading zeroes.

INTERPRETATION OF BYTE STATUS

	Bit 7	Bit 6	Bit 5	Bit 4	Bit 3	Bit 2	Bit 1
Motor Off	x	x	x	x	x	x	0
Motor On	x	x	x	x	x	x	1
Over SFR ($\geq 115.0\%$) ¹	x	x	x	x	x	1	x
Valid FSR ($< 115.0\%$)	x	x	x	x	x	0	x
Value Outside Limits ²	x	x	x	x	1	x	x
Value Within Limits	x	x	x	x	0	x	x
Calibration Error	1 ³	x	x	x	x	x	x
¹ Bit 2 is set in response to an R command (request for information) only. ² If an input is received that is outside the allowable limits for a command, Bit 3 shall be set for the response to that command only. Once the response to the command has been sent to the host, Bit 3 shall be cleared again. ³ This bit is set in response to a calibration command if an error occurred in the respective operation							

Table 2

Example:

1. The CAP 2000+ has been turned on with the proper cable inserted in the serial port placing the unit in its external mode.
2. The host computer sends an **I**. The CAP 2000+ responds with an **ICAPHI2201000000**, indicating a high temperature CAP 2000+ with Version 2.20 firmware, spring constant of 1.00, and a status byte of 0.
3. The host sends a **T190**. The CAP 2000+ begins controlling to 40.0°C and responds with **T100**.
4. The host sends **V1F4**. The CAP 2000+ ramps to 500 rpm and responds with **V02** indicating the motor is running.
5. The host sends a **T9C4**. The request to control temperature to 250.0°C is illegal. The CAP 2000+ responds with **T0A** indicating a temperature request outside the limits of the instrument.
6. The host sends an **R**. The CAP 2000+ responds with **R002B1115950A25A83E80102** indicating a viscosity reading of 11.025 Poise, a FSR reading of 55.25%, a shear rate of 6650 1/sec, a sensed temperature of 100.0°C, and a number one cone. Note that Bit 3 of the status byte has been cleared. It is set only in response to the offending command (**T9C4**) and is cleared as soon as the response is issued.

TABLE OF CONTENTS

I. INTRODUCTION.....	3
I.1 Components.....	3
I.2 Utilities.....	4
I.3 Specifications	4
I.4 Installation.....	5
I.5 Safety Symbols and Precautions	6
I.6 Key Functions	7
I.7 Viscosity and Temperature Display.....	7
I.8 Cleaning	8
II. GETTING STARTED	9
II.1 Power ON	9
II.2 Cone Spindle Selection and Setting	10
II.3 Speed Setting.....	11
II.4 Temperature Control Setting.....	12
II.5 Hold Time Settings	12
II.6 Run Time	12
II.7 Printing	13
II.8 Run and Stop Keys.....	13
II.9 Parameter Display.....	14
III. OPERATION.....	15
III.1 Full Scale Range and Accuracy of Measurement.....	15
III.2 Accuracy of Viscosity and Temperature	16
III.3 Calibration Verification.....	18
III.4 Cone Calibration.....	21
III.5 Repeatability	22
III.6 Making Viscosity Measurements	23
III.7 Computer Control.....	25
APPENDIX A - Variables in Viscosity Measurement	26
APPENDIX C - Warranty Repair and Service	28

This manual intended for use with CAP 2000+ series viscometers which have serial numbers beginning with a prefix of "CPN".

CAP1000 and 2000 Viscometers with a serial number prefix of "CP" require a different manual. Please contact Brookfield or your authorized dealer/representative to obtain this manual.

I. INTRODUCTION

The CAP 2000+ Series Viscometers are medium to high shear rate instruments with Cone Plate geometry and integrated temperature control of the test sample material. Rotational speed selection ranges from 5 to 1000 RPM. Viscosity measurement ranges depend upon the cone spindle and the rotational speed (shear rate). Viscosity is selectively displayed in units of centipoise (cP), poise (P), milliPascal seconds (mPa•s) or Pascal seconds (Pa•s). Temperature control of sample is possible between either 5°C (or 15°C below ambient, whichever is higher) and 75°C or 50°C and 235°C depending on viscometer model.

The CAP 2000+ Viscometer can display either **CGS** or **SI** units:

	<u>CGS</u>	<u>SI</u>	<u>Comment</u>
Viscosity:	P or cP	Pa•s or mPa•s	0.1 Pa•s = 1 P (= 100 cP)
Shear Rate:	SEC ⁻¹	SEC ⁻¹	
Speed:	RPM	RPM	
Temperature:	°C	°C	

The CAP 2000+ Viscometer outputs data to a parallel printer in the **CGS** and **SI** units:

	<u>CGS</u>	<u>SI</u>	<u>Comment</u>
Viscosity:	P or cP	Pa•s or mPa•s	0.1 Pa•s = 1 P (= 100 cP)
Full Scale Range (F.S.R.):	%	%	
Shear Stress:	Dynes/cm ²	N/m ²	1.0 N•m = 10 ⁷ dyne•cm
Shear Rate:	SEC ⁻¹	SEC ⁻¹	
Speed:	RPM	RPM	
Run Time:	Seconds	Seconds	
Temperature:	°C	°C	
Cone Spindle Number:	No.	No.	

I.1 Components

The following items are included; see Figure I-1

	<u>Part No.</u>
1. CAP 2000+ Viscometer	
2. Cone Spindle(s).....	CAP-S-0X (X will be shown as a number 1-10)
3. Spindle Case	CAP-106Y
4. Solvent Trap	CAP-1K-63
5. Power Cord: 115V.....	DVP-65
220V	DVP-66
UK.....	DE-8
Germany	DE-7
6. Operating Instructions Manual	M/02-313

The following optional items may have been included:

	<u>Part No.</u>
7. Viscosity Standard Fluid for calibration	See Table III-5 and III-6 in Section III

Please check to be sure that you have received all components and that there is no damage. If you are missing any parts, please notify Brookfield or your local dealer immediately. Any shipping damage must be reported to the carrier. Save the packing container, if possible, for future use when returning the viscometer to Brookfield or an authorized dealer for service.

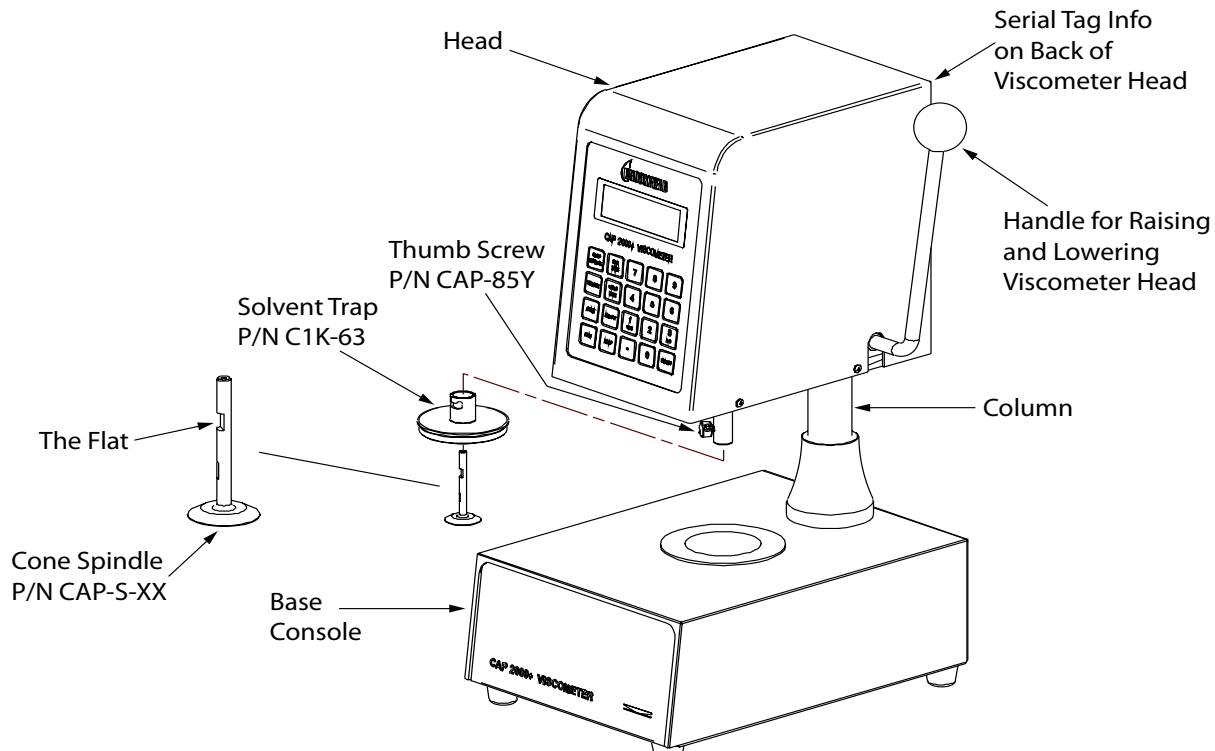

Figure I-1: Components

I.2 Utilities

Input Voltage: 115 VAC or 230 VAC
 Input Frequency: 50/60 Hz
 Power Consumption: Less than 345 WATTS
 Fuses: (2) 5x20mm, 3A, 250V; Fast Acting for 125VAC
 (2) 5x20mm, 1.6A, 250V; Fast Acting for 250VAC

Power Cord Color Code:

	<u>United States</u>	<u>Outside United States</u>
Hot (live)	Black	Brown
Neutral	White	Blue
Ground (earth)	Green	Green/Yellow

I.3 Specifications

Torque Range: Low 797-7,970 dyne•cm (designated on serial tag as 1/23 CAP)
 High 18,100-181,000 dyne•cm (designated on serial tag as 1.0 CAP)
 Speeds: Variable speed from 5-1000 RPM

Temperatures: CAP 2000+L 5°C (or 15°C below ambient, whichever is higher) to 75°C
 CAP 2000+H 50°C to 235°C
 All models provide 0.1°C increments

Weight: Gross Weight 36 lb 16.3 kg
 Net Weight 27 lb 12.3 kg
 Carton Volume 4.9 cu ft 0.15 m³
 Carton Dimensions 18 in. L x 18 in. W x 26 in. H
 48 cm. L x 48 cm. W x 66 cm. H

Materials: CAP cone spindles and temperature plates are made of tungsten carbide.

Operating Environment: CAP 2000+ Viscometers **must** be operated within the following ambient temperatures: **+5°C (41°F) to 40°C (104°F)** and humidity: **20% to 80% R.H. (non-condensing atmosphere)**

I.4 Installation

Note: DO NOT lift the viscometer by the handle or head! LIFT only by the base console or column!

- 1) Set the viscometer on a clean level bench surface.
- 2) **Remove shipping foam insert from the plate area on the CAP Viscometer.** Store the foam insert for future use when shipping or transporting CAP Viscometer.

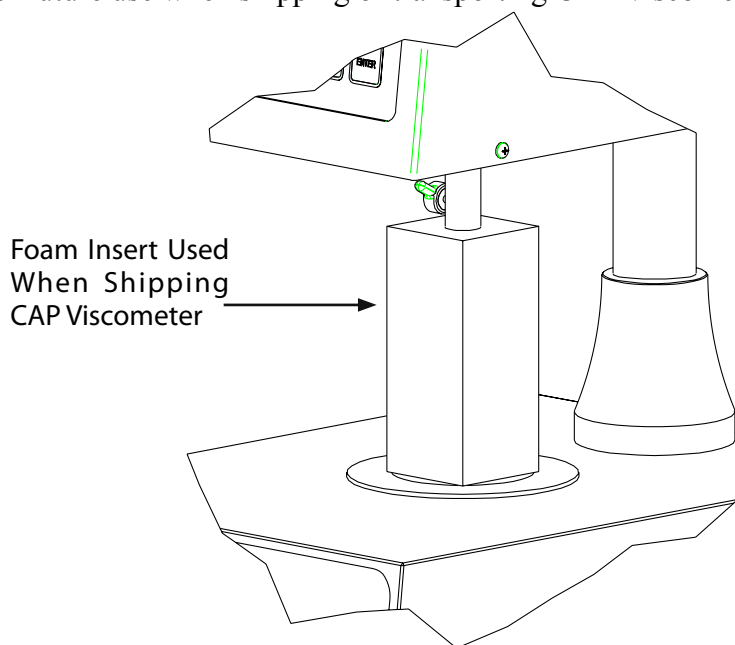

Figure I-2: Detail of Foam Insert

- 3) Verify that the viscometer's power requirements match your power source **BEFORE** connecting it to power.

The AC input voltage and frequency must be within the appropriate range as shown on the back of the viscometer head.

Note: The CAP Viscometer must be earth grounded. Use the three (3) wire power cord! Do not alter!

- 4) Connect the power cord to the viscometer and to the power supply (source).
- 5) If using a printer, connect the printer cable to the printer port and printer.

Note: Ensure that both the printer and the CAP 2000+ are off when connecting cables.

I.5 Safety Symbols and Precautions

Safety Symbols

The following explains safety symbols which may be found in this operating manual.



Indicates hazardous voltages may be present.



Caution: HOT surface.



Refer to the manual for specific warning or caution information to avoid personal injury or damage to the instrument.

Safety Overview



If this instrument is used in a manner not specified by the manufacturer, the protection provided by the instrument may be impaired.



This instrument is not intended for use in a potentially hazardous environment.



In case of emergency, turn off the instrument and then disconnect the electrical cord from the wall outlet.

I.6 Key Functions

Figure I-3 shows the control keys on the face of the viscometer display panel:

NUMERIC 0 - 9

These keys are used for data entry

ENTER

This key accepts entered data.

STOP / ESCAPE

Stops cone spindle rotation at any time. Exits data entry field.

DELETE

This key clears entered values for input selections.

PRINT

This key sends data to the parallel printer, when connected.

RUN

This key starts spindle rotation.

RUN TIME

This key selects time entry mode (time of spindle rotation).

HOLD TIME

This key selects time entry mode (wait time before spindle rotates).

SPINDLE

This key selects the cone spindle entry mode.

TEMP

This key selects the temperature entry mode.

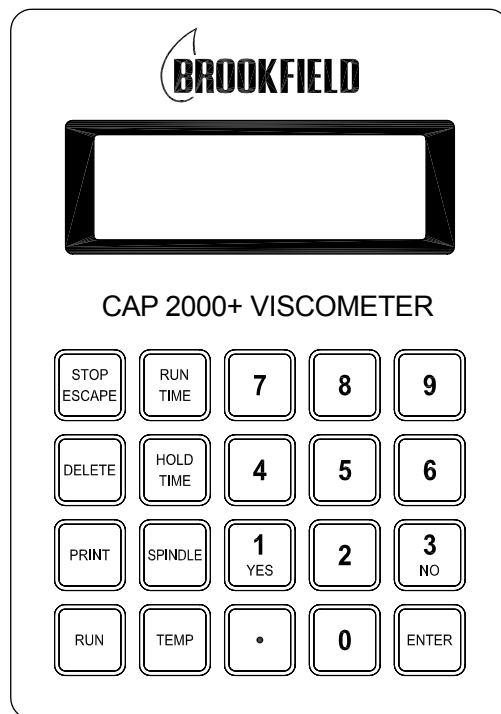

Figure I-3

I.7 Viscosity and Temperature Display

Viscosity is displayed in either **P=Poise** or **cP=Centipoise** (CGS system) or **Pa•s=Pascal seconds** or **mPa•s=milliPascal seconds** (SI system). If the viscosity measurement is over range, “EEEE” will be displayed. Brookfield recommends a minimum torque reading of 10% when making viscosity measurements. If the torque value is between 0 and 10%, the display will flash to indicate an under range condition. If the viscometer final reading is below zero, negative values will be displayed.

Temperature is displayed in **°C=degrees centigrade**.

I.8 Cleaning

Instrument, Keypad & Painted Surfaces:

Clean with dry, non-abrasive cloth. Do not use solvents or cleaners.

Immersed Components (spindles/cones) and temperature controlled plate:

All immersed components are made of carbide steel. Clean with non-abrasive cloth and solvent appropriate for sample material that is not aggressive to immersed components.

Do not use metal objects to clean the plate surface, as scratching of the plate may occur and compromise cone calibrations.

Note: When cleaning, take care not to apply excessive force which may bend the spindle shaft or otherwise damage the instrument.

II. GETTING STARTED

II.1 Power ON

Turn the power **ON** using the switch located on the rear of the base console.

The start-up screen will be displayed for four seconds and will indicate the viscometer model, version number and torque range.

```
BROOKFIELD
CAP 2000+ VISCOMETER
VERSION 1.10
1.0 CAP
```

Figure II-1

After four (4) seconds, the main screen will be displayed (Figure II-2).

```
0.00P    0.0%
Run 15    Spindle 04
50.0C    900 RPM
```

Figure II-2

The instrument will be set to the default temperature:

CAP L Series Viscometer	25.0°C
CAP H Series Viscometer	50.0°C

If the CAP 2000+ Viscometer is connected to a PC via the serial port on the rear of the base console, the main screen display is EXTERNAL.

Special Functions

Units of measure and speed control may be selected through the **special functions screen**. This screen is accessed by pressing the **STOP** key during instrument power up.

The CAP 2000+ can be configured to control speed by either rotations per minute (RPM) or shear rate (1/SEC). This selection is set by choosing **1=SPEED CONTROL** in the **special functions screen**, then selecting **1=RPM** or **2=1/SEC** and pressing **ENTER**.

The CAP 2000+ can be configured to display viscosity in one of four units: **Poise (P)**, **Centipoise (cP)**, **Pascal Seconds (Pa•s)** or **milliPascal seconds (mPa•s)**. This selection is set by choosing **2=Units of Measure** in the **special functions screen**, selecting **1=P**, **2=cP**, **3=Pa•s**, or **4=mPa•s**, and then pressing **ENTER**.

Once the CAP 2000+ has been configured, the instrument must be turned **OFF**. The configuration will be stored in memory.

Note: When operating the CAP 2000+ with shear rate as the method of speed control, the shear rate value entered may be adjusted based on the shear rate multiplier for the spindle. For example: if using cone 4 (shear rate multiplier of 3.33), an entered shear rate of 51 1/SEC will be displayed as 50 1/SEC.

II.2 Cone Spindle Selection and Setting

Raise the viscometer handle to its highest position.

The CAP cones have viscosity ranges as shown in Appendix A. After selecting the appropriate cone for the viscosity range to be utilized, *carefully* attach the cone to the viscometer as shown in Figure II-3.

Be sure to insert the spindle completely into the adapter sleeve; align the flat (see Figure I-1) on the spindle with the thumb screw and then tighten.

When using the solvent trap (Figure II-2), connect it to the cone adapter by sliding it up, passing the slot by the thumb screw and turning the trap clockwise onto the thumbscrew. Slide the cone up into the adapter as far as it will go and hand lock it in place with the thumb screw. Tighten the thumb screw firmly and securely.

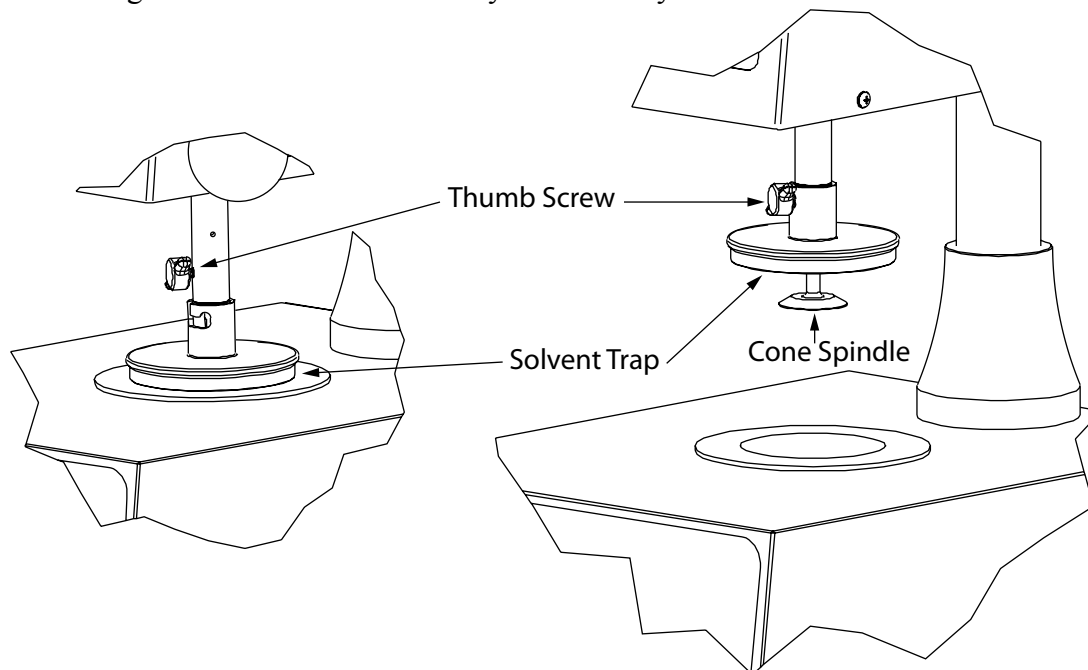

Figure II-3: Cone Attachment

Press the **SPINDLE** key. The display will change to the spindle entry screen. Using the number keys, type in the required spindle number.

Two digits must be entered for the cone number. For cone **01** through **09**, the first number remains as “0”.

Note: The default cone setting on power-up will be the last cone entry prior to shutting off the viscometer.

After the correct two (2) digits have been entered, press the **ENTER** key and the cone will be accepted for viscometer calculations. The screen will display the following message:

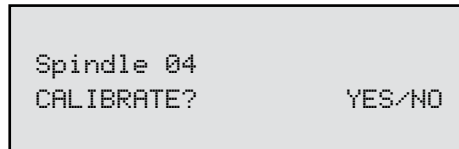

Figure II-4

If you are using the CAP Viscometer for the first time or have just received the instrument back from being serviced, press YES and see Section III. Cones supplied at the time of order are calibrated to the viscometer by Brookfield prior to shipment, but should still be verified with a calibration check prior to use for the first time. Cones purchased separately at a later time by the user must also be calibrated prior to making viscosity measurements.

Otherwise, there is no requirement to perform a cone calibration.

- Note:**
1. CAP Viscometers allow for **only one** cone at a time of the **same cone number** to be calibrated to the viscometer. Multiple cones of the same cone number **must each be calibrated** to the viscometer before operation (refer to **Section III**).
 2. A special feature of the CAP series viscometers allows the user to perform a cone calibration with viscosity standard fluids.
 3. Cones entered as 11 through 99 must be first calibrated following the directions in **Section III**.

If you are not going to calibrate the cone, continue by pressing the **NO** key, then the **ENTER** key. The viscometer will display the **MAIN SCREEN (Figure II-1)**.

If you are going to calibrate the cone, press the **YES** key, refer to **Section III** and follow the calibration instructions under **Cone Calibration**.

II.3 Speed Setting

The CAP 2000+ is a variable speed viscometer. The speed of rotation is shown in the lower right corner of the display. To change the speed of rotation, enter the new speed using the number keys. The new speed will be shown in the lower right hand corner of the display. To accept the new speed, press **ENTER**.

The new speed may be cancelled by pressing **ESCAPE** before pressing **ENTER**.

To begin spindle rotation, press the **RUN** key.

Note: The speed cannot be changed while the motor is running.

Speed control may be configured to either shear rate or rotations per minute (see Special Functions in section II.1). Data entry for speed selection is the same in either configuration.

Data entry must be in whole numbers.

II.4 Temperature Control Setting

Press the **TEMP** key and the current temperature setting will blink. The default temperature on start-up is **25.0°C** on low temperature models and **50.0°C** on high temperature models.

The temperature ranges are:

Low temperature: 5°C (or 15°C below ambient, whichever is higher) to 75°C
High temperature: 50°C to 235°C

Use the number keys to type in the required set point. The temperature can be set in increments of **0.1°C**. You can turn off the heater by entering 0 on the high temperature unit only.

Use the **ENTER** key to accept the new set point.

Note: *Thermal equilibrium* of the sample and of the spindle must be considered for best measurement results. Upon powering up the Viscometer or after changing the temperature set point, allow sufficient time for the plate to reach the desired temperature. It is recommended to have the spindle in contact with the plate prior to introducing the sample material to ensure that the spindle is also at the temperature of test. Brookfield recommends using the solvent trap at all times to enhance the temperature control of the sample material. After inserting the sample material onto the plate, lower the spindle and solvent trap and allow sufficient time for thermal equilibrium prior to starting the test.

Temperature control on the high temperature unit can be restored by entering a setpoint between 50°C and 235°C.

II.5 Hold Time Settings

Hold time sets the time period between when the **RUN** key is pressed and when the spindle begins to rotate. This time period is normally used to ensure thermal equilibrium of the sample and spindle. The hold time range is 0 to 999 seconds.

Press the **HOLD TIME** key and the current hold time will blink on the default screen. Use the number keys to type in the required hold time and press the **ENTER** key.

Note: When the hold time is set to zero, it is not displayed on the default screen.

II.6 Run Time

Run time sets the time period of spindle rotation. The run time range is 0 to 999 second.

Press the **RUN TIME** key and the current run time will blink on the default screen. Use the number keys to type in the required run time and press the **ENTER** key.

Note: Run time will be shown on the default screen only when hold time is set to zero.

A run time of zero sets the viscometer to infinite run mode. In this mode, the spindle will rotate at the set speed for as long as the **RUN** button is pressed. When the **RUN** key is released, the spindle will stop rotating.

Note: With a run time of zero, the hold time will not be used.

The time required for reading stabilization will depend on the speed of rotation and the nature of the test sample. Longer runs times are recommended at lower speeds.

Speed	Run
50-1000 RPM	12 seconds
20-50 RPM	20 seconds
5-20 RPM	30 seconds

II.7 Printing

Pressing the **PRINT** key at any time sends information on test parameters to the printer port. However, viscosity, full scale range and shear stress data will only be printed after it is first displayed during a test run.

To print a heading, press and hold the **STOP/ESCAPE** key and press the **PRINT** key. Then start the test by pressing the **RUN** key. Press the **PRINT** key whenever data is desired during the test.

Example of CAP 2000+ PRINT OUTPUT showing heading and data.

VISCOSITY (POISE)	F.S.R. (%)	TEMP (Deg C)	S.STRESS (D/CM2)	S.RATE (1/sec)	SPEED (RPM)	TIMER (SEC)	CONE No.
-	-	25.0	-	10000	0750	20	02

Figure II-5

A maximum of 999 seconds can be printed when running in manual **TIMER** mode (00). Over 999 seconds will print **EEE**.

The **TIMER (SEC)** column will indicate the accumulated time of running at the moment the print key is pressed while the cone is rotating. This time value will not include the hold time.

At the end of a test, data will automatically be sent to the printer port.

II.8 Run and Stop Keys

The **RUN** key has three functions:

1. Press **RUN** to begin a test.
2. Press and hold the **RUN** key for continuous rotation when **00** is the timer setting.
3. Used in executing a cone calibration.

The **STOP** key has three functions:

1. Stops the cone rotation at any time.
2. Pressing and holding the **STOP/ESCAPE** key during power up selects the special functions mode where the viscosity display units and speed of rotation may be changed. (Section II.1)

- Pressing and holding the **STOP** and **PRINT** keys simultaneously executes the printing of a new heading (Section II.7).

II.9 Parameter Display

The parameter display will appear, as shown in Figure II-6, immediately after the **RUN** key is pressed. All relevant measurement parameters will be shown for 5 seconds including speed, shear rate, run time, hold time and spindle. The display will return to the default screen after five seconds.

Note: The viscometer will be operating according to the selected parameters while the parameter display screen is shown.

Speed	15 RPM
Shear Rate	50 1/sec
Run 20 S	Hold 10S
Spindle 04	

Figure II-6

III. OPERATION

The CAP 2000+ Viscometer rotates a precisely machined cone spindle over a temperature controlled plate shearing the test sample over a range of speeds from 5 to 1000 RPM. This provides a comprehensive capability to analyze materials for viscosity behavior as a function of both shear rate and temperature. Tests can be run in standalone mode or under PC control. This chapter explains how to use the CAP 2000+ toward these objectives.

III.1 Full Scale Range and Accuracy of Measurement

Full Scale Range (FSR) viscosity is the maximum viscosity that can be measured and occurs when the % torque is 100. Brookfield recommends that viscosity measurements be made between 10 and 100% torque.

There are two tables to consult for viscosity range information, depending on which torque model viscometer you purchased. To determine which torque model you have, consult the serial tag of your viscometer or the certificate of calibration that accompanied the instrument or the display on power up.

23CAP 2000+ = **Low Torque** CAP 2000+ = **High Torque**

Full Scale Range (FSR) is based on the cone spindle your are using, the torque model of your viscometer, and the speed of spindle rotation. The tables below provide information on FSR by torque model for the most common factory set speeds:

Table III-1: Full Scale Range Viscosity for Low Torque CAP 2000+

Cone Number	Cone Range Constant	Shear Rate Constant	FSR Poise at 100 RPM	FSR Poise at 750 RPM	FSR Poise at 900 RPM	FSR Poise at any RPM
01	1875	13.33N	0.83	0.11	.0597	1875/(22.7*N)
02	3750	13.33N	1.65	0.22	.165	3750/(22.7*N)
03	7500	13.33N	3.30	0.44	.330	7500/(22.7*N)
04	15000	3.33N	6.61	0.88	0.73	15000/(22.7*N)
05	30000	3.33N	13.22	1.76	1.47	30000/(22.*N)
06	75000	3.33N	33.04	4.41	3.67	75000/(22.7*N)
07	3150	2N	1.39	*	*	3150/(22.7*N)
08	12500	2N	5.51	*	*	12500/(22.7*N)
09	50000	2N	22.3	*	*	50000/(22.7*N)
10	5000	5N	2.20	0.29	2.20	5000/(22.7*N)

N= RPM

Poise x 100 = centiPoise

*use of this cone at these RPM is not recommended

Table III-2: Full Scale Range Viscosity for High Torque CAP 2000+

Cone Number	Cone Range Constant	Shear Rate Constant	FSR Poise at 100 RPM	FSR Poise at 750 RPM	FSR Poise at 900 RPM	Poise at any RPM
01	1875	13.33N	18.75	2.50	2.08	1875/N
02	3750	13.33N	37.50	5.00	4.17	3750/N
03	7500	13.33N	75.00	10.00	8.33	7500/N
04	15000	3.33N	150.00	20.00	16.67	1500/N
05	30000	3.33N	300.00	40.00	33.33	30000/N
06	75000	3.33N	750.00	100.00	83.33	75000/N
07	3150	2N	*	*	*	3150/N
08	12500	2N	*	*	*	12500/N
09	50000	2N	*	*	*	50000/N
10	5000	5N	50.00	6.67	5.56	5000/N

N= RPM

Poise x 100 = centiPoise

*Use of this cone at these RPM is not recommended

You can also determine FSR for any speed selection that is not in the above tables by doing a simple calculation:

- For Low Torque CAP instruments:

Cone range constant / (22.7 * N) = FSR (Poise) where N = RPM

- For High Torque CAP instruments:

Cone range constant / N = FSR (Poise) where N = RPM

The last column in the above tables shows this calculation.

III.2 Accuracy of Viscosity and Temperature

The following tables indicate the accuracy of the viscosity measurement for the CAP 2000+ Viscometer using CAP spindles 01-10. This accuracy depends on both the rotational speed of the cone and the percent of Full Scale Range (%FSR) in Poise at which the viscosity is measured. Accuracy is stated in Poise (P) and is calculated as a % of the FSR viscosity.

To calculate accuracy:

- Determine FSR viscosity in Poise for the torque model, cone spindle, and speed of rotation, using the information in Tables III-1 or III-2.
- Find the column that best defines the speed of rotation used for the measurement and your reported % FSR from the measurement.
- Consult the table below to determine the accuracy of your measurement
- Multiply the accuracy by the FSR viscosity if you need your accuracy stated in Poise.

Table III-3: Accuracy for Low Torque CAP 2000+

Cone	≤400 RPM	750 RPM	900 RPM	900 RPM
	10-100% FSR	10-100% FSR	≤50% FSR	>50% FSR
01	±2.0%	±2.0%	±2.0%	±2.0%
02	±2.0%	±2.0%	±2.0%	±2.0%
03	±2.0%	±2.0%	±2.0%	±2.0%
04	±2.0%	±2.0%	±2.0%	±2.0%
05	±2.0%	±2.0%	±2.0%	±2.0%
06	±2.0%	±2.0%	±2.0%	±2.0%
07	±2.0%	*	*	*
08	±2.0%	±2.0%	±2.0%	±2.0%
09	±2.0%	±2.0%	±2.0%	±2.0%
10	±2.0%	±2.0%	±2.0%	±2.0%

* Not recommended for use at these RPM

Table III-4: Accuracy for High Torque CAP 2000+

Cone	≤400 RPM	750 RPM	900 RPM	900 RPM
	10-100% FSR	10-100% FSR	≤50% FSR	>50% FSR
01	±2.0%	±2.0%	±2.0%	±4.0%
02	±2.0%	±2.0%	±2.0%	±4.0%
03	±2.0%	±2.0%	±2.0%	±4.0%
04	±2.0%	±3.0%	±3.0%	±6.0%
05	±2.0%	±4.0%	±4.0%	±8.0%
06	±2.0%	±5.0%	±5.0%	±10.0%
07	±2.0%	*	*	*
08	±2.0%	*	*	*
09	±2.0%	*	*	*
10	±2.0%	±2.0%	±2.0%	±2.0%

* Not recommended for use at these RPM

The specification of temperature accuracy on CAP Viscometers is stated below:

LOW TEMP UNITS:

- In ambient conditions of 15°C to 30°C, accuracy is +/- 0.5°C when the temperature set point on the viscometer is 5°C to 75°C.
- In ambient conditions outside of 15°C to 30°C, accuracy is +/- 1.0°C when the temperature set point on the viscometer is 5°C to 75°C.

HIGH TEMP UNITS:

- In ambient conditions of 15°C to 30°C, accuracy is +/- 0.5°C when the temperature set point on the viscometer is 50°C to ≤100°C.

- In ambient conditions of 15°C to 30°C, accuracy is +/- 1.0°C when the temperature set point on the viscometer is 101°C to 235°C.
- In ambient conditions outside of 15°C to 30°C, accuracy is +/- 2.0°C when the temperature set point on the viscometer is 50°C to ≤100°C.

III.3 Calibration Verification

Accuracy of the CAP 2000+ Viscometer can be verified by performing a calibration verification.

The cones/spindles that were shipped with the viscometer were calibrated to the viscometer by Brookfield prior to shipment. If your viscometer was returned to Brookfield or an authorized Brookfield Dealer, then any cones/spindles that were returned for service will have been calibrated to the viscometer prior to shipment.

When you receive the instrument, perform a calibration verification on each cone spindle to ensure that each spindle is measuring correctly. This will ensure that everything is in good working order and that the instrument and/or cone spindles have not experienced a change during shipment. If the calibration verification fails then you can take advantage of the CAP Viscometer's unique feature which allows the operator to recalibrate each cone spindle to the CAP Viscometer (See Section III.4).

Calibration verification is also performed when viscosity readings with your product are suspect. Verifying the calibration will determine if the cone needs to be recalibrated to the instrument. This will help you to determine if the discrepant readings on your product are due to cone/instrument performance, or your method or your product. Complete cone recalibration is discussed in Section III.4.

To perform a cone calibration verification, you will need a mineral oil from Table III-5 or Table III-6. Determine what range model CAP 2000+ Viscometer you have (Low Torque or High Torque), which temperature range (L = Low, H = High; consult the instrument serial tag) and what cone you are using.

You must use the following method, regardless of what your test calls for:

1. Put the cone in the down position, and make sure that the solvent trap is covering the spindle.
2. Allow the viscometer to stabilize for at least 30 minutes at 25°C (Low Temp units) or at 60°C (High Temp) if the temperature that you normally operate is different; otherwise, wait 5 minutes, then make sure the cone is in the down position and that the solvent trap is on.
3. At the end of the temp stabilization period, dispense the appropriate volume of fluid (consult Table III-5 or Table III-6). Figure III-1 shows how to dispense the fluid onto the plate and determine visually if the amount is appropriate.

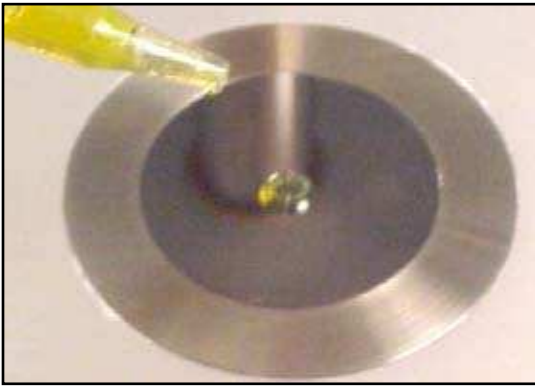

Figure III-1a

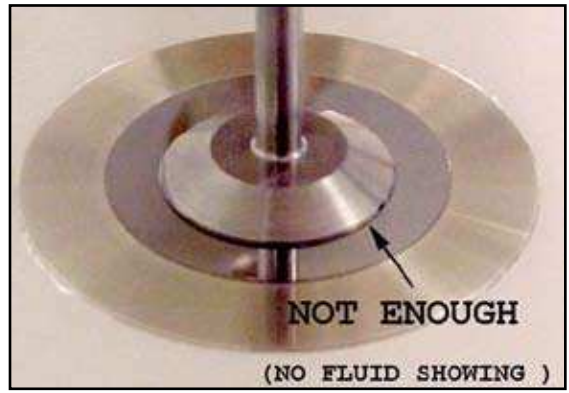

Figure III-1b

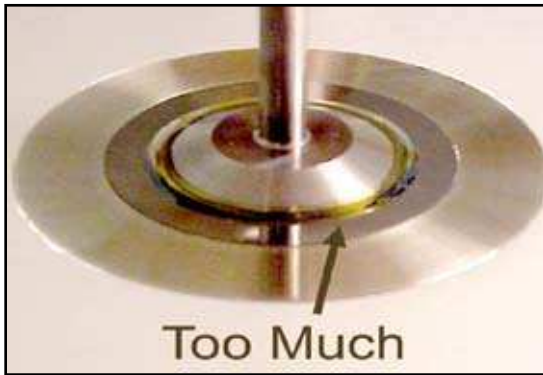

Figure III-1c



Figure III-1d

4. Run a viscosity test and record the viscosity value when the reading has stabilized.
5. Compare the recorded viscosity to the actual value of the standard and verify that it falls within the accuracy limits stated in Tables III-3 and III-4.
6. If the test fails, repeat again to make sure that every step was performed correctly. If the test fails again, perform a cone calibration according to the procedure in Section III.4.

Table III-5: Viscosity Standard Fluids for Calibration of CAP Spindles on Low Torque CAP 2000+

LOW TORQUE	LOW TEMP				LOW TORQUE	HIGH TEMP			
Cone	Fluid Part Number	Nominal Value (cP)	Temp (°C)	Sample Size (micro liters)	Cone	Fluid Part Number	Nominal Value (cP)	Temp (°C)	Sample Size (micro liters)
CAP-S-01	CAP0L	57	25	67	CAP-S-01	CAP0H	57	60	67
CAP-S-02	CAP1L	89	25	38	CAP-S-02	CAP1H	89	60	38
CAP-S-03	CAP2L	177	25	24	CAP-S-03	CAP2H	177	60	24
CAP-S-04	CAP3L	354	25	124	CAP-S-04	CAP3H	354	60	124
CAP-S-05	CAP4L	708	25	67	CAP-S-05	CAP4H	708	60	67
CAP-S-06	CAP5L	1417	25	32	CAP-S-06	CAP5H	1417	60	32
CAP-S-07	CAP1L	89	25	1700	CAP-S-07	CAP1H	89	60	1700
CAP-S-08	CAP3L	354	25	400	CAP-S-08	CAP3H	354	60	400
CAP-S-09	CAP5L	1417	25	100	CAP-S-09	CAP5H	1417	60	100
CAP-S-10	CAP2L	177	25	170	CAP-S-10	CAP2H	177	60	170

Table III-6: Viscosity Standard Fluids for Calibration of CAP Spindles on High Torque CAP 2000+

HIGH TORQUE	LOW TEMP				HIGH TORQUE	HIGH TEMP			
Cone	Fluid Part Number	Nominal Value (cP)	Temp (°C)	Sample Size (micro liters)	Cone	Fluid Part Number	Nominal Value (cP)	Temp (°C)	Sample Size (micro liters)
CAP-S-01	CAP1L	89	25	67	CAP-S-01	CAP0H	89	60	67
CAP-S-02	CAP2L	177	25	38	CAP-S-02	CAP2H	177	60	38
CAP-S-03	CAP2L	354	25	24	CAP-S-03	CAP3H	354	60	24
CAP-S-04	CAP3L	708	25	124	CAP-S-04	CAP4H	708	60	124
CAP-S-05	CAP4L	1417	25	67	CAP-S-05	CAP4H	1417	60	67
CAP-S-06	CAP5L	3542	25	32	CAP-S-06	CAP5H	3542	60	32
CAP-S-07	CAP6L	1328	25	1700	CAP-S-07	CAP6H	1328	60	1700
CAP-S-08	CAP7L	5313	25	400	CAP-S-08	CAP7H	5313	60	400
CAP-S-09	CAP8L	21250	25	100	CAP-S-09	CAP8H	21250	60	100
CAP-S-10	CAP9L	236	25	170	CAP-S-10	CAP9H	236	60	170

III.4 Cone Calibration

A special feature of the **CAP Series** Viscometers allows the user to perform a cone calibration using Viscosity Standard Fluids. This field calibration will accommodate any wear on the tip of the cone which may result from contact with the plate.

Note: A cone calibration should be performed when: 1) using a new cone for the first time, 2) switching between two cones of the same number and 3) verification of calibration provides data outside of the acceptable range.

Refer to Tables III-5 and III-6 to choose the calibration fluid for the spindle being calibrated.

1. Turn on the CAP 2000+ Viscometer.
2. Attach solvent trap to coupling shaft.
3. Attach spindle.
4. Place appropriate amount of sample onto the center of the Viscometer plate directly below the spindle.
5. Pull down the handle, locking it into the lowest position, placing the spindle in contact with the plate.

6. Lower the solvent trap.

Note: The solvent trap must be utilized when calibrating to ensure proper temperature control.

7. Select the spindle to be calibrated by using the **SPINDLE** key.
8. Select **YES** for **CALIBRATE** and press **ENTER**.
9. Enter the appropriate values for temperature (**°C**) and viscosity (**cP**) prompted by the screen.

Note: Viscosity values are always entered in units of **CENTIPOISE (cP)** no matter what units have been selected as unit of measure for normal operation.

$$100 \text{ cP} = 1\text{P}; 1\text{cP} = 1\text{mPa}\cdot\text{s}; 1000 \text{ cP} = 1\text{Pa}\cdot\text{s}$$

Note: The Viscometer temperature control must be identical to the specified temperature for the viscosity standard when executing the calibration. Normally calibration will be at 25°C for “L” Series CAP Viscometers and 60°C for “H” Series CAP Viscometers.

10. Allow at least 30 minutes for thermal equilibrium of the plate, calibration fluid and spindle, from instrument cold start.

11. Select the spindle speed.

All of the spindles used with the low torque CAP 2000+ instruments should be calibrated at 100 RPM when using the recommended viscosity standard fluids. This practice will calibrate the instrument at approximately the middle of the Full Scale Range.

Spindles used with the high torque CAP 2000+ and the recommended viscosity standard fluids may be calibrated at any speed.

12. Press the **RUN** key to start the calibration.

Note: The calibration process may be cancelled at any time prior to pressing RUN by pressing the ESCAPE key.

When calibration is complete, spindle rotation will stop and the “CALIBRATION COMPLETE” screen is displayed. (See Figure III-2). Press ENTER to continue.

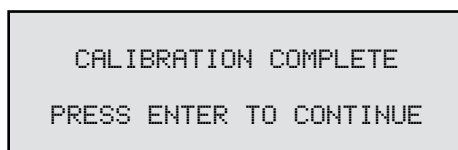

If the viscometer is connected to a printer, the printout (Figure III-3) will automatically be generated. There will be values for the listed variables. The operator can enter the information by hand on the bottom of the printout.

CONE (00) CALIBRATION								
VISCOSITY (POISE)	FSR (%)	TEMP (Deg C)	S.STRESS D/CM ²	S.RATE (1/sec)	SPEED (RPM)	TIMER (SEC)	CONE No.	SAMPLE No.
Operator: _____								
Date: _____								
Model/Serial #: _____								
Fluid: _____								

Figure III-3

III.5 Repeatability

The CAP 2000+ Viscometer is repeatable to $\pm 0.5\%$ of the full scale viscosity range (FSR). Due to shear heating considerations which occur in high shear rate instrumentation, the measurement of NIST Viscosity Standard Fluids at rotational speeds above 900 RPM will show a decrease in viscosity with an increase in rotational speed (shear rate).

Normal forces due to the shearing of a viscoelastic fluid (such as paint) are accounted for in the CAP Series Viscometers by weight on the spindle column of 3.4 Newtons (340,000 Dynes)

total force. This is done to avoid having the cone lift off the plate, thereby changing the cone plate geometry and producing incorrect viscosity readings. For normal forces greater than 3.4 Newtons (340,000 Dynes) total force, additional externally mounted weights are required. However, more weight means more wear on the cone and plate. Additional weights should only be considered when definitely required and removed when not required.

Contact Brookfield Engineering Laboratories or your Brookfield Dealer/Distributor/Representative for details on the above information.

III.6 Making Viscosity Measurements

The following procedure is recommended for making a viscosity measurement.

With the viscometer on a clean, level surface, connect it to the proper power supply (Section I.4).

1. Turn the power switch **ON** (Section II.1).

The procedure assumes that the following have been done:

- a) If the viscometer has been “off” for an extended period (i.e., overnight) a “warm up” period of 30 minutes is suggested. You may choose to warm up at the temperature of test. If a cone calibration is to be done immediately after the warm up period, temperature should be set to 60°C (calibration temperature for high temperature instruments) or 25°C for low temperature instruments to save some time.
 - b) The cone calibration procedure should have been done for all cones which are used with the instrument. Cone calibration is only required when a new cone (i.e., replacement for lost/damaged cone) is used, or when calibration check fails.
 - c) When making measurements with low temperature instruments (CAP 2000+L), the solvent trap may not be required (for the containment of solvents and/or prevention of sample “drying”). The trap should be used for all measurements with high temperature instruments (CAP 2000+H).
 - d) If a printer is to be used, it should be connected (AC power & viscometer to printer cable). The CAP 2000+ will print automatically when a reading is taken if the printer is connected and “on line.”
2. Select and attach the cone (Section II.2).
Notes:
 - a. Lock the cone tightly into the adapter.
 - b. When measuring volatile samples such as paints and coatings, and when using either a high temperature CAP 2000+H or CAP 2000+L, the solvent trap must be put in place over the cone to prevent the test sample from drying out during the rotation of the cone.
 3. Set the temperature control (Section II.5).
 4. Set the cone number.
 5. Lower the handle placing the cone onto the plate. Lock the handle into its lowest position. Drop the solvent trap over the cone.

Note: Allow ten (10) minutes for the cone to come to equilibrium temperature with the plate.

- Secure trap on shaft.  Solvent trap may be hot, spindle & plate too. Raise the handle. Place the sample to be measured onto the plate below the cone and solvent trap. Don't use plastic spatulas/syringes if the plate temperature is above 50°C. Refer to **Table III-5 or III-6** for recommended sample sizes. Lower the cone and solvent trap.

- Notes:**
- Lower the handle **gently**. **DO NOT FORCE THE CONE ONTO THE PLATE.**
 - The sample must completely cover the face of the cone and extend beyond the edge of the cone about 1.0 mm.
 - Release the solvent trap placing it onto the plate over the cone so it does not touch the cone shaft.



The user should ensure that the substances placed under test do not release poisonous, toxic or flammable gases at the temperatures to which they are subjected to during the testing.

- Allow the cone, plate and sample to equilibrate to the temperature control setting.

Note: A minimum of one (1) to three (3) minutes equilibrium time is recommended, depending upon the sample.

- Set the **Run Time** for rotating the cone (Section II.6) and the Hold Time.
- Put the printer on-line (optional, Section II.7).
- Press the **RUN** key and execute the viscosity measurement.

Note: Due to the dynamics of shearing a fluid in the CAP “H” series Viscometers, the temperature display may indicate a deflection from the equilibrium temperature setting as the cone begins rotating at high shear rates. The temperature display may indicate the temperature of the plate and the momentary changes show the cycling of the temperature control at high temperature. The precision of the viscosity measurement is maintained within the limits specified in Table 3.1.

- Read the results of the sample test on the printer or write down the test conditions and viscosity results from the viscometer display.

- Relocate the solvent trap onto the cone adapter and raise the handle.



Caution: HOT surface.

- It is recommended to remove the cone for cleaning. However, with care, the cone can be cleaned in place.



Caution: HOT surface.

14. Clean the viscometer plate (refer to Section I.8).



Caution: HOT surface.

III.7 Computer Control

The CAP 2000+ Viscometer can be operated remotely under PC control when using the CAP-CALC application software.

When advanced sample analysis is required, Brookfield CAPCALC application software can control the CAP 2000+ Viscometer from a PC. CAPCALC for Windows requires Windows 2000 operating system or higher. CAPCALC application software displays, prints and stores tabulated data files (Brookfield, Excel).

CAPCALC software has automatic data capture (up to 200 data points per test) and graphical data display (rheograms) to facilitate analysis of test samples. The software also allows temperature control of the sample plate for integrated viscosity/temperature tests between 5°C and 75°C (CAP 2000+L) or 50°C and 200°C (CAP 2000+H) depending on viscometer model. CAPCALC features include on-screen and printed plots of % F.S.R., viscosity or shear stress vs. cone speed, shear rate, time or temperature. Also available are automatic calculation of Yield Stress (Bingham Plastic or Casson) and Power Law Consistency Index.

Additional information on the communications protocol for CAP 2000+ is contained in **Appendix B**.

Contact Brookfield or our authorized agent to obtain the CAPCALC software program.

APPENDIX A - Variables in Viscosity Measurements

As with any instrument measurement, there are variables that can affect a Viscometer measurement. These variables may be related to the instrument (Viscometer), or the test fluid. Variables related to the test fluid deal with the rheological properties of the fluid, while instrument variables would include the Viscometer design and the spindle geometry system utilized.

Rheological Properties

Fluids have different rheological characteristics that can be described by Viscometer measurements. We can then work with these fluids to suit our lab or process conditions.

There are two categories of fluids:

- Newtonian** - These fluids have the same viscosity at different Shear Rates (different RPMs) and are called Newtonian over the Shear Rate range they are measured.
- Non-Newtonian** - These fluids have different viscosities at different shear rates (different RPMs). They fall into two groups:
 - 1) Time Independent non-Newtonian
 - 2) Time Dependent non-Newtonian

The time dependency is the time they are held at a given Shear Rate (RPM). They are non-Newtonian, and when you change the Viscometer spindle speed, you get a different viscosity.

Time Independent

- Pseudoplastic** - A pseudoplastic material displays a decrease in viscosity with an increase in shear rate, and is also known as “shear thinning”. If you take Viscometer readings from a low to a high RPM and then back to the low RPM, and the readings fall upon themselves, the material is time independent pseudoplastic and shear thinning.

Time Dependent

- Thixotropic** - A thixotropic material has decreasing viscosity under constant shear rate. If you set a Viscometer at a constant speed, recording **P** values over time, and find that the **P** values decrease with time, the material is thixotropic.

Brookfield publication, “**More Solutions to Sticky Problems**” includes a more detailed discussion of rheological properties and non-Newtonian behavior.

Viscometer Related Variables

- Most fluid viscosities are found to be non-Newtonian. They are dependent on Shear Rate and the spindle geometry conditions. The specifications of the Viscometer cone and plate geometry will affect the viscosity readings. For example, if one reading is taken at 750 rpm, and a second at 900 rpm, the two viscosity values produced may be different because the readings were made at different shear rates. The faster the spindle speed, the higher the shear rate.
- The shear rate of a given measurement is determined by the rotational speed and the cone angle.
- A repeatable viscosity test should control or specify the following:
 1. Viscometer model
 2. Cone used
 3. Test temperature
 4. Test speed [or the shear rate]
 5. Length of time to record viscosity
 6. Sample volume sufficient to cover the face of the cone

APPENDIX B - Warranty Repair and Service

Warranty

Brookfield Viscometers are guaranteed for one year from date of purchase against defects in materials and workmanship. They are certified against primary viscosity standards traceable to the National Institute of Standards and Technology (NIST). The Viscometer must be returned to **Brookfield Engineering Laboratories, Inc.** or the Brookfield dealer from whom it was purchased for warranty service. Transportation is at the purchaser's expense. Remove the spindle from the viscometer and attach the shipping cap to the pivot cup to prevent shipping damage. The Viscometer should be shipped in its carrying case together with all spindles originally provided with the instrument.

For repair or service in the **United States** return to:

Brookfield Engineering Laboratories, Inc.
11 Commerce Boulevard
Middleboro, MA 02346 U.S.A.
Telephone: (508) 946-6200 FAX: (508) 923-5009
www.brookfieldengineering.com

For repair or service outside the United States consult Brookfield Engineering Laboratories, Inc. or the dealer from whom you purchased the instrument.

For repair or service in the **United Kingdom** return to:

Brookfield Viscometers Limited
1 Whitehall Estate
Flex Meadow, Pinnacles West
Harlow, Essex CM19 5TJ, United Kingdom
Telephone: (44) 27/945 1774 FAX: (44) 27/945 1775
www.brookfield.co.uk

For repair or service in **Germany** return to:

Brookfield Engineering Laboratories Vertriebs GmbH
Hauptstrasse 18
D-73547 Lorch, Germany
Telephone: (49) 7172/927100 FAX: (49) 7172/927105
www.brookfield-gmbh.de

For repair or service in **China** return to:

Guangzhou Brookfield Viscometers and Texture Instruments Service Company Ltd.
Room C1, 5/F, Tianxing Building East Tower, No. 21, Zhongshan Yi Road, Yuexiu District
Guangzhou, 510600, P. R. China
Telephone: (86) 20/3760-0548 FAX: (86) 20/3760-0548
www.brookfield.com.cn

On-site service at your facility is also available from Brookfield. Please contact our Service Department in the United States, United Kingdom, Germany or China for details.

PACKAGING INSTRUCTIONS TO RETURN A BROOKFIELD CAP VISCOMETER FOR REPAIR OR CALIBRATION

Package the viscometer for shipment as outlined below.

Return the viscometer to the attention of the Repair Department (see address below).

RUSH SERVICE MUST BE INDICATED ON THIS FORM AND CLEARLY MARKED ON THE OUTSIDE OF YOUR SHIPPING PACKAGE.

- Remove and return all spindles (properly packed for shipping). DO NOT RETURN WITH THE SPINDLE ATTACHED.
- Clean excess testing material off the instrument.
- Include MSDS sheets for all hazardous materials tested with this instrument.
- If you have shipping foam block, as shown in Figure 1, please use it to support the shaft. If you don't, use a suitable material of similar length.

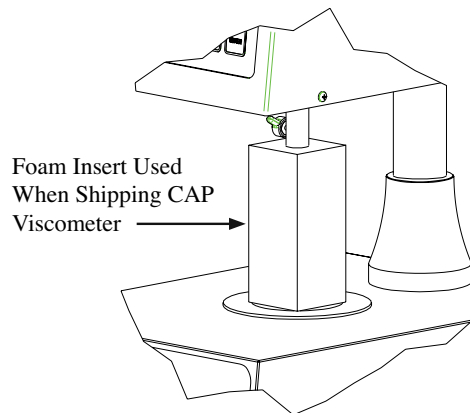

Figure 1

- Enclose the instrument in a plastic bag.
- Pack the instrument in its original case. Cases are available for immediate shipment from Brookfield. If the case is not available, take care to wrap the instrument with enough material to support it. Avoid using foam peanuts or shredded paper.
- Fill out page 1 of this Laboratory Repair Return Form with as much information as possible to help expedite your service. If you do not have this form, you can download it from our website: www.brookfieldengineering.com/support/maintenance
-or -
Email us at CCS@brookfieldengineering.com
TEL 508-946-6200 or 800-628-8139 FAX 508-923-5009
- Package the instrument and related items in a strong box for shipping. Mark the outside of the box with handling instructions.
Example: "Handle with Care" or
"Fragile - Delicate Instrument"
"Rush" if appropriate
- Contact Brookfield or our authorized dealer for Return Authorization Number. Mark number on outside of package and on Repair Return Form.



ISO 9001:2000 CERTIFIED
Brookfield Engineering Laboratories, Inc. • 11 Commerce Boulevard • Middleboro, MA 02346 USA

with offices in: Boston • Chicago • London • Stuttgart • Guangzhou

Tel: 800.628.8139 or 508.946.6200 Fax: 508.946.6262 www.brookfieldengineering.com



LABORATORY REPAIR RETURN FORM

Please call our Repair Department for a Return Authorization Number, fill out this form completely and return it with your instrument. Failure to do so will delay the repair process.

IMPORTANT:

1. Brookfield recommends that all viscometers be returned for annual calibration.
2. **Calibration & Certification Service is automatically performed for instruments that require torque sensing adjustments and/or repair.**
3. There is a \$96.00 evaluation fee for repair estimates; this fee will be waived for instruments that receive service.
4. Requests for RUSH service must be indicated on the shipping package and accompanying paperwork.
5. We will contact you **ONLY** if repairs exceed \$400.00.

CONTACT/USER INFORMATION (Please Print)

Primary Contact: _____ Phone No. _____
 Fax No. _____ Email: _____

BILLING:

Company _____
 Address _____

SHIPPING:

Company _____
 Address _____

INSTRUMENT INFORMATION

Model: _____ Please describe all problems/malfunctions: _____
 Serial No: _____

OPERATING CONDITIONS

Spindle: _____ Speed: _____ Viscosity Range: _____ Temperature Control: _____
 Sample Temperature: _____ Accessories: _____

SERVICE AND RETURN INSTRUCTIONS Please check service(s) required and describe problematic symptoms above.

- Calibration & Certification Service > NOTE: this service is required for instruments that require torque sensing adjustments/repair
- CAP or QTS Service (please describe any problematic symptoms above)
- Cone Spindle Calibration (each spindle returned on Cone & Plate or CAP Viscometers)
- Ball Bearing Suspension Retrofit* (Includes Calibration & Certification Service)
*Note (Available for DV-I+/Prime, DV-II+/PRO Viscometers, and DV-III+/Ultra Rheometers in torque ranges RV, HA, and HB)
- N.I.S.T. Traceability (includes copies of the certificates for all the reference equipment used to calibrate your equipment)
- 24 Hour Rush Service (not available for Cone & Plate or CAP Viscometers)
- 48 Hour Rush Service > NOTE: Rush Service will also increase above Cone Spindle Calibration Service
- Loan Instrument

If you return a Model D Helipath, Thermosel Container, or Thermosel Controller, these will be serviced as well and each item will be billed on a separate invoice even if all items were sent together.

RETURN SHIPPING F.O.B. Middleboro, MA

UPS: Ground Next Day 2nd Day Collect** **FEDERAL EXPRESS**:** 2nd Day Standard Overnight Priority Overnight

(**Your account number is **required** for all Federal Express shipments and for UPS collect): _____

PAYMENT: Please note that we will only contact you if repairs exceed \$400.00.

Visa MasterCard American Express Purchase Order No. _____

Name on Credit Card: _____

Expiration Date _____

Account No. _____

Return Authorization No.
