



LAB Online Exhibition



Operation Manual



knowledge



Action movie

Contents

1	Scope of delivery	2	5	Operation	11
1.1	Glass oven for drying	2	5.1	Overview program structure	11
1.2	Glass oven for ball tube (Kugelrohr) distillation	3	5.2	Basic display arrangement	12
			5.3	Operation of the B-585 Drying	16
2	Safety	5	5.4	Operation of the B-585 Kugelrohr	19
2.1	Symbols	5	5.5	Accessories: Sublimation and freeze drying	22
2.2	Requirements to be met by the customer	5	5.6	Converting the Glass Oven configurations	23
2.3	Proper use	5			
2.4	Improper use	6	6	Maintenance	26
2.5	General hazards	6	6.1	Cleaning	26
2.6	Safety measures	7	6.2	Service	26
2.7	Over-temperature protection	7	6.3	Customer service	26
3	Function	8	7	Taking out of operation	27
3.1	Working with the glass ovens	8	7.1	Storage / Transport	27
			7.2	Disposal	27
4	Putting into operation	10	8	Replacement parts	28
4.1	Installation location	10	8.1	B-585 Drying configuration replacement parts	28
4.2	Power connections	10	8.2	B-585 Kugelrohr configuration replacement parts	29
4.3	Installation of the glass parts and the drive unit	10	8.3	Sublimation accessory replacement parts	29
			9	Appendix	30
			9.1	Technical data	30
			9.2	Error messages	30
			9.3	Materials used	31
			9.4	Declaration of conformance	32



Please read these instructions thoroughly before using the **BÜCHI** Glass Oven **B-585**. Keep these instructions in the immediate vicinity of the device so that they can be referred to at any time.

Chapter 2 contains important safety advice. These information is vital to the safe operation of the glass oven.

The right to make technical changes without notice is reserved. No portion of these instructions may be reproduced in any manner, nor may it be edited, copied or distributed using any electronic or optical systems without the expressed written consent of Büchi Labortechnik AG.

All rights reserved.

Copyright © Büchi Labortechnik AG, 2004

en, Version C

as of Software-Version 1.1 (32 pages)

Order Code

B-585 Instructions

96981

1 Scope of delivery



Fig. 1: B-585 Drying

1.1 Glass oven for drying

Description	Order Code
B-585 Drying	
Drying oven B-585 100 V - 230 V / 50/60 Hz	46600

Additional package contents:

2 Replacement fuses 3,15 AT	
1 Drying accessory complete	37010
1 Mains cable PNE, 1.5m	
Typ CH	10010
Typ Schuko	10016
Typ GB	17835
Typ USA	10023
Typ AUS	17836
1 Instructions	
German	96980
English	96981
French	96982
Italian	96983
Spanish	96984



Fig. 2: Ball tube drive complete

Optional accessories

1 Complete ball tube drive for converting to a ball tube distillation oven (Kugelrohr) incl. cooling device	46617
1 Complete sublimation accessory for conversion to the Sublimation configuration	37133
1 Communication cable B-585 / V-500	46728

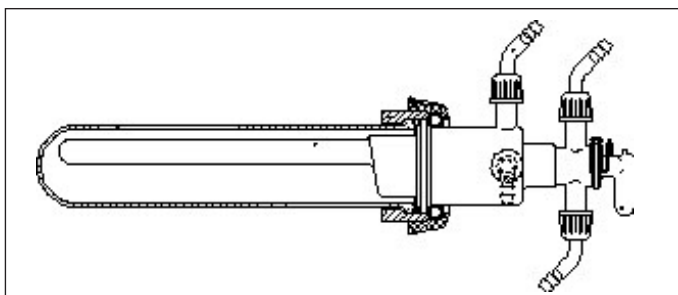

Fig. 3: Sublimation accessory complete



Fig. 4: B-585 Kugelrohr configuration

1.2 Glass oven for ball tube (Kugelrohr) distillation

Description

B-585 Kugelrohr configuration	Order Code
Kugelrohr distillations oven B-585 100 V - 230 V / 50/60 Hz	46601

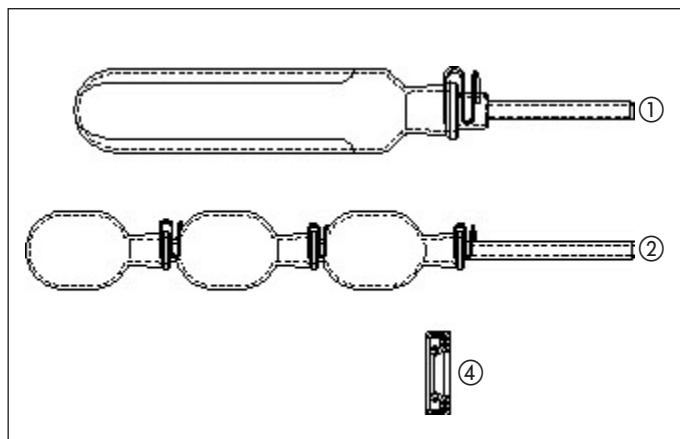

Fig. 5a: Glass Accessories including with B-585 Kugelrohr configuration

Additional package contents:

1 30 ml rotation drying flask with vapour duct and clip ①	37143
1 20 ml ball tube with vapour duct and clips ②	37107
1 Replacement gasket for the ball tube drive ④	37288
1 10 g tube of vacuum grease	17595
2 Replacement fuses 3,15 AT	
2 GL 14 hose nipples	37287
1 Iris diaphragm cpl. ⑤	46605
1 Cooling unit compl. ③	46616
1 3-wire power cord. 1.5m	
Type CH	10010
Type Schuko	10016
Type GB	17835
Type USA	10023
Type AUS	17836
1 Instructions	
German	96980
English	96981
French	96982
Italian	96983
Spanish	96984

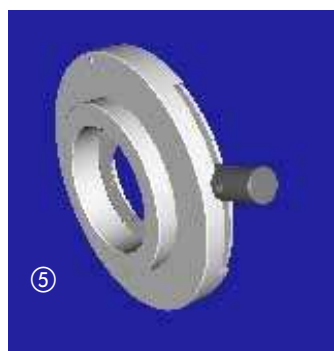

Fig. 5b/c: Other Accessories including with B-585 Kugelrohr configuration

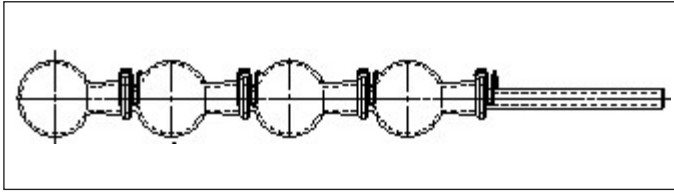

Fig. 6a: 10 ml ball tube

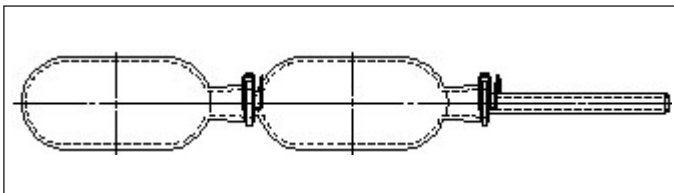

Fig. 6b: 40 ml ball tube

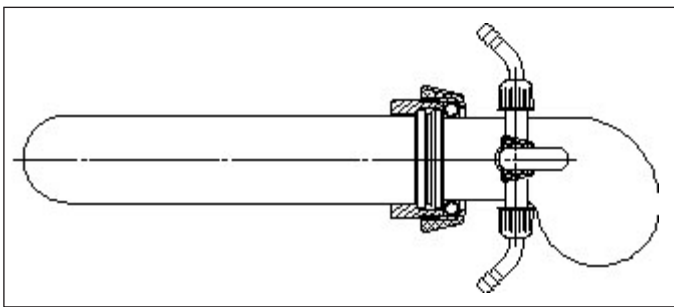

Fig. 6c: Drying accessory

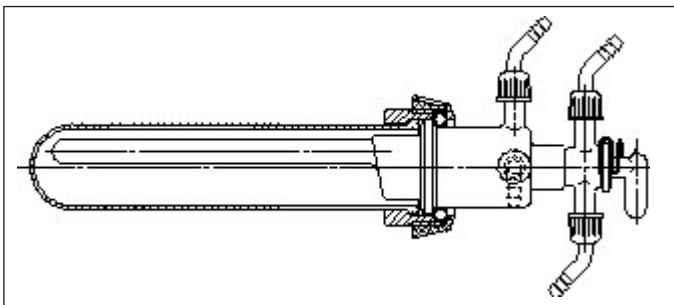

Fig. 6d: Complete sublimation accessory

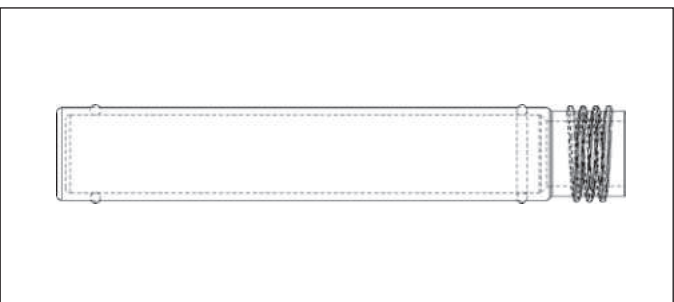

Fig. 6e: The freeze drying accessory

Optional accessories

1 10 ml ball tube with vapour duct and clips	37118
1 40 ml ball tube with vapour duct and clips	37117
1 Drying accessory for converting to the B-585 Drying model	37010
1 Complete sublimation accessory for converting to the B-585 Sublimation model	37133
1 Freeze drying accessories	46710

2 Safety

The device has been built using state art techniques and in accordance with the recognized safety regulations. There are no risks or hazards associated with the use of this device if used according to the instructions.

2.1 Symbols

**Stop**

Information about hazards which can lead to serious material damage or cause serious or potentially fatal injury.

**Warning**

Information about hazards which can be harmful to your health and lead to material damage.

**Please note**

Information about technical requirements. Non-observance can lead to malfunctions, inefficiency and lost production.

2.2 Requirements to be met by the customer

The device may only be used by laboratory personnel and other persons who, due to their training or experience, can recognize the hazards associated with operating the device.

Personnel without this type of training or persons currently in training require careful instruction. This instruction can be considered to be the basis for this instruction manual.



When working with solvents whose composition is not known, it is the management's responsibility to obtain information from the appropriate persons about possible hazards associated with using such solvents.

2.3 Proper use

The device has been designed and built as a laboratory device. Appropriate uses of the device are for the drying, distillation, sublimation and freeze-drying of small quantities of substance from room temperature up to 300°C.

2.4 Improper use

Using the device for any other purpose other than those stated above or using in any application that does not correspond to the technical data is considered to be improper usage. Any damage resulting from such use is the sole responsibility of the operator.

Using the device in the following situations is especially prohibited:

- Using the device in rooms which require explosion-proof equipment.
- Testing samples which, through impact, friction, heat or sparking, may explode or ignite (for example, explosives, etc.).
- Using in conjunction with solvents containing peroxides

2.5 General hazards



General hazards arise from:

- When using with mixtures with unknown composition or impurities.
- Flammable solvents (attend the burning point)
- Toxic gases, which can result during operation.
- Flammable gases or solvent fumes in or around the device.
- Damaged glassware.
- When the device is too close to the wall (see Chapter 4, Putting into operation)
- Touching the heating elements, causing burns.
- Squeezings by inappropriate retracting and extending of the drive or adjustment of the heating angle.
- Storage of the unit in confined places when hot.



Rotation drive

Care must be taken to ensure that hair, clothing, jewelry or any other article is prevented from entering any rotating parts of the instrument.

Removing the cover using common hand tools is - except for authorized maintenance personnel, prohibited. The device may not be put into operation if the glassware is damaged.

It may be fatal if any high voltage parts of the device are touched!

Use of dry ice

Dry ice can cause serious burns if allowed to come into contact with skin or eyes. Appropriate protective clothing must be worn. **NB** Dry ice will foam strongly if allowed to come into contact with acetone.

2.6 Safety measures

It is required that you wear protective gear such as **protective glasses, gloves** and a **lab coat**.

These instructions must be available at all times to the operating personnel at the location where the device has been installed, as it is considered to be a component of the glass oven. This is also true of the copies of the instructions in other languages, which may be ordered separately at a later date.



Modifications

Modifications to the device or to the replacement parts or accessories, as well as using any replacement parts or accessories other than those mentioned in these instructions, is only allowed with the express written consent of Büchi Labortechnik AG.

Responsibilities of the Management

The management is responsible for instructing its personnel. To help in this task, you can order these instructions in several other languages.



Protective Shield

The protective shield mounted on the device does not serve to completely protect the operator from coming into contact with hot glass elements. It is only there to protect the operator from burns occurring due to carelessness.

2.7 Over-temperature protection

The device has an over-temperature cut-out for the protection of samples and the oven. This protective device switches the heating off in the event of the oven temperature reaching 320°C:

- For additional information, please see. Troubleshooting; Chapter 9.2 Error messages

3 Function

3.1 Working with the glass ovens

The core of the glass oven comprises two borosilicate glass tubes lying one within the other. The outer tube (1) protects against damage to the heating tube, and at the same time prevents contact with parts that are electrically live. A metal screen (2) around the outer jacket provides additional protection. The transparent, electrically conductive semi-conductor coating, does the actual heating. Temperatures up to 300°C are attained, the oven temperature being monitored via an integral temperature sensor (4). A lock nut (5) can be used to tilt the oven and to secure it in a suitable position.

The basic equipment can be used for drying, distilling and sublimating, if the appropriate accessories are used.

To avoid thermal damage to, or decomposition of, samples requires gentle heating techniques. Conventionally, this has been done by heating the sample via an intermediate medium (e.g. water or oil) whose temperature is regulated just above the required setpoint for the sample. In bulb-tube distillations, a semi-conductor coating is used to provide direct, yet still gentle, heating. The product may be heated directly because the heat source provides evenly across the entire surface of the heater. Because the thermal capacity and the thermal conductivity of the vapour-coated glass are significantly better than those of the gas/atmosphere outside, most of the heat given off is taken up by the glass and radiated inwards. There are further advantages in addition to the gentle heating: Because 75% of the heat is supplied to the product through radiation and only 25% via heated gas, the oven heats up very quickly and also cools down relatively quickly when it is switched off. In addition, because the semi-conductor is fully transparent, the sample can be observed during the drying process, so that any decomposition can be identified quickly and any necessary countermeasures can be taken in time.

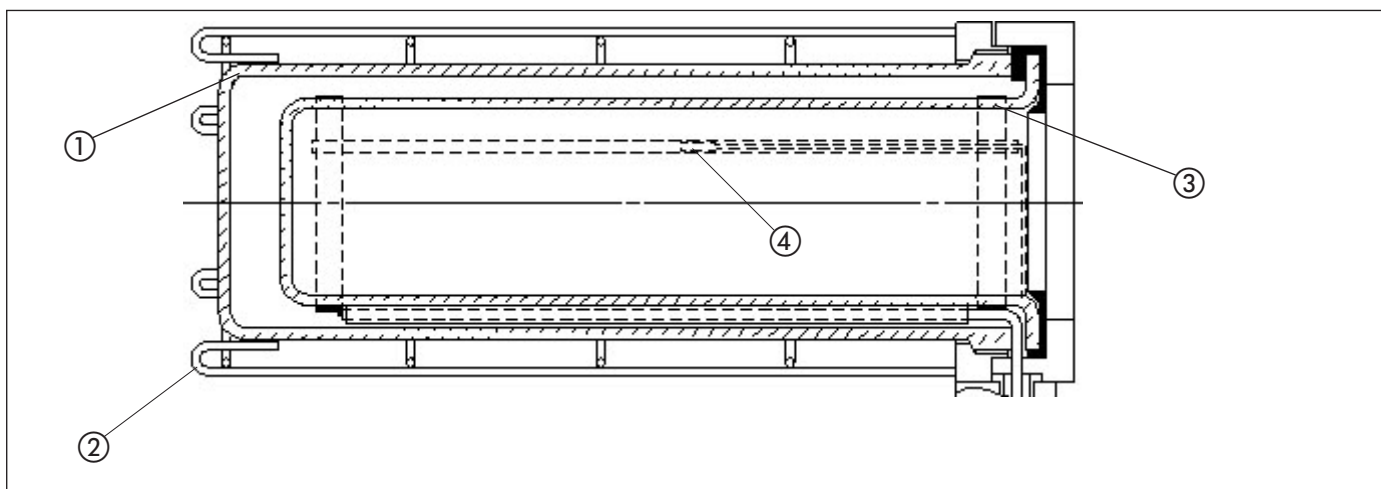

Fig. 7: Function principle of the glass oven

- ① Jacket tube
- ② Heat protection
- ③ Heating tube
- ④ Temperature sensor



The electrically conductive semiconductor layer operates at supply voltage. There is a possibility for fatal injuries when the outer jacket tube has been removed.

4 Putting into operation



Please inspect the package for any damage while unpacking. Any damage suspected of having occurred during transportation should be reported immediately to the appropriate authorities (distributor, post office, railroad or trucking company).

The original packaging should be saved in case it is required at a later date.

4.1 Installation Location

The device must be set up on a clean, stable and level surface.

The device may not be used in rooms meant for use with explosive gases.



For safety reasons, there **must be at least 30 cm** between the wall or other equipment and the rear and sides of the device. No containers, chemicals or other devices should be placed behind the device.

4.2 Power connections



Check to ensure that the voltage coming out of the electrical socket agrees with the voltage stated on the devices ratings plate. The glass oven must always be connected to an earthed electrical socket. External couplings and extension cords must have an earth wire (3-pole couplings, cords and sockets). It is prohibited to cut or interrupt the earth wire. to avoid the risk of damage to the device, or personal injury.



In a vertical operation care must be taken to ensure that every cable of the B-585 not gets in contact with the heating element.

Discription of the interface:

Drive:	interface for the drive unit
Vac Pump:	interface for communications cable B-585/V-500 to a vacuum pump V-500
Air Pump:	interface for air pump Mettler for the KF-Method (not avaiilabel at Büchi)

4.3 Installation of the glass parts and the drive unit

For installation of the different parts please see chapter 5.6 "Converting the Glass Oven".

5 Operation

5.1 Overview of program structure

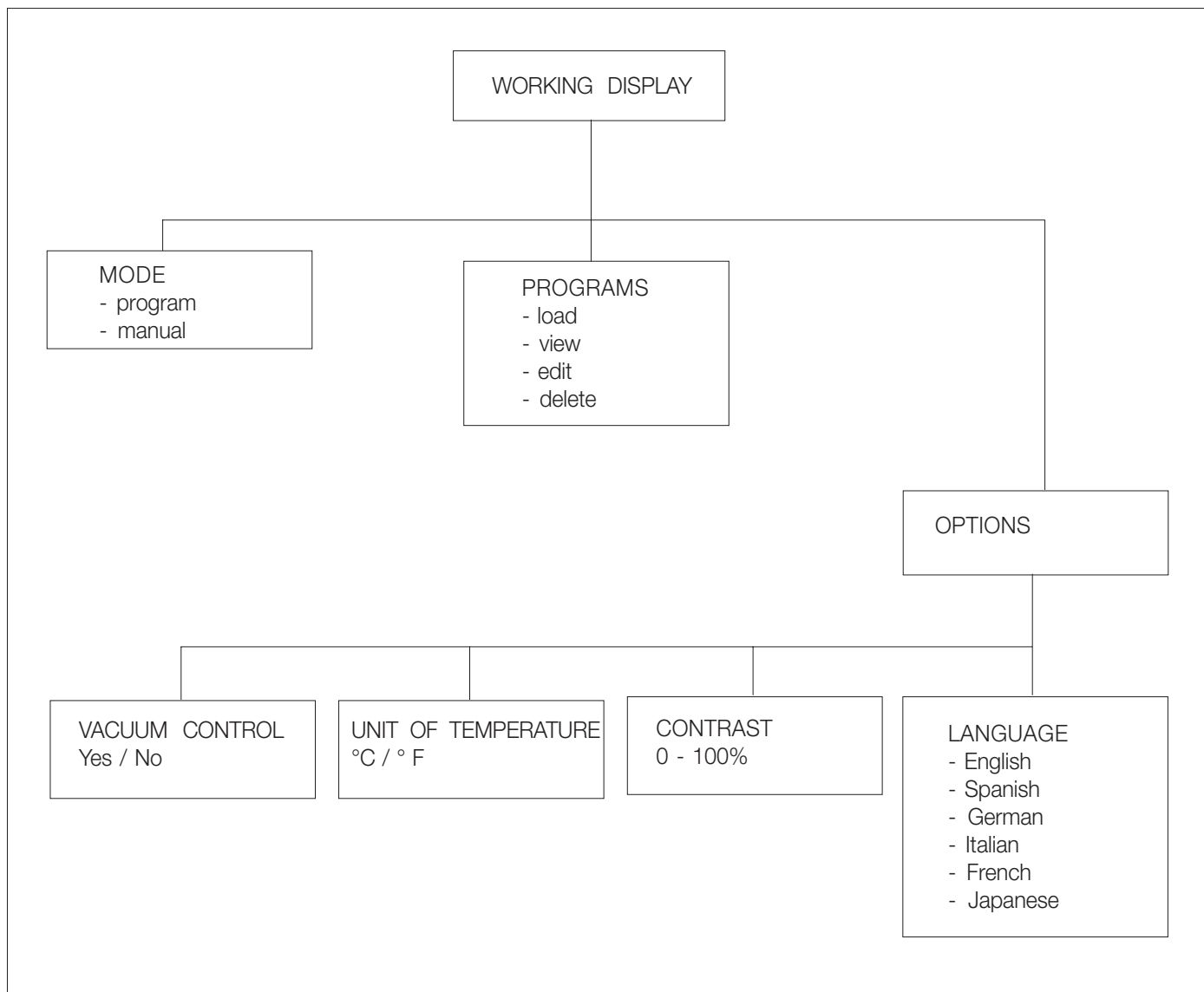
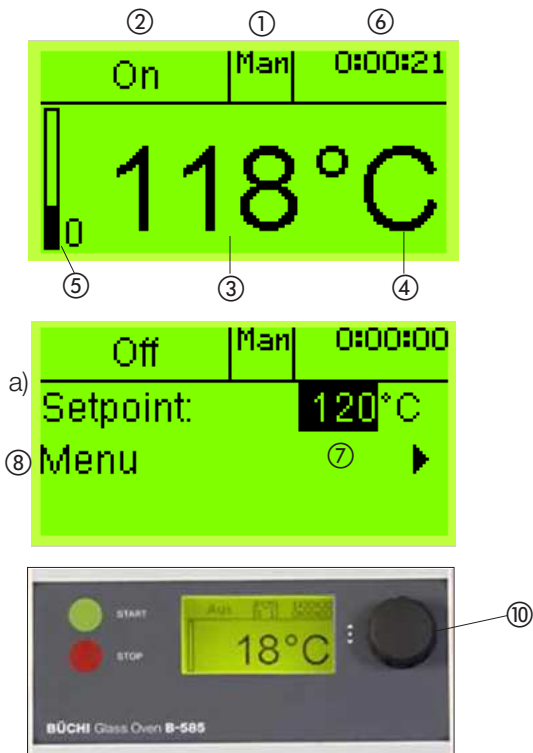

Fig. 8: Overview of program structure B-585



5.2. Basic display arrangement

- ① Active mode information
- ② Operating condition
- ③ Actual temperature
- ④ Temperature unit of measurement
- ⑤ Graphic display of heating intensity
- ⑥ Display of the elapsed time
- ⑦ Set point adjustment
- ⑧ Menu adjustment
- ⑨ Graphical display, shows level indication of the user
- ⑩ Multifunction button

By pressing and turning the Multifunction button allows access to the *working menu* where changes and modifications can be made. Pressing the Multifunction button again activates the set point. An *existing value* can be modified by turning the Multifunction button and is stored by pressing the button again. The cursor will jump forward to the display *menu*.

By turning the Multifunction button you get back to the actual working menu or access another control mode. It is possible to change/create, delete, read or load a program profile in the menu *program* or change the *main settings*.

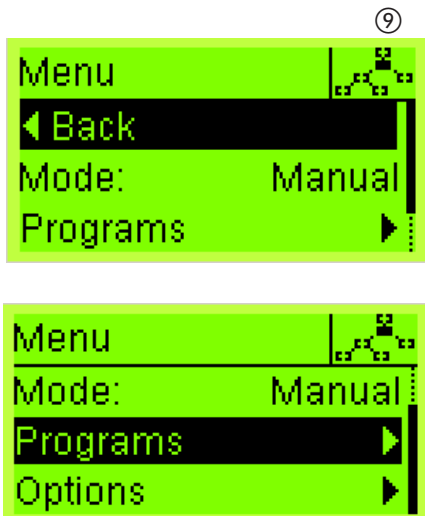

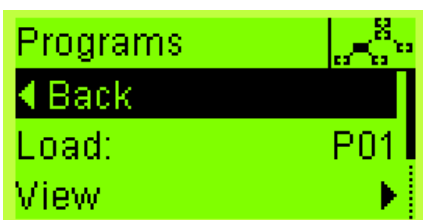
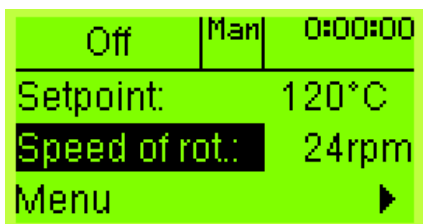

5.2.1 Operation of the B-585 in manual mode

Changing the actual temperature and the speed of rotation in manual mode.

By pressing the Multifunction button the user gets into the working menu, where the changes to the actual *temperature set point* and the *rotation speed* can be made. Pressing the Multifunction button again activates the menu *set point*. To select the desired temperature turn the button. By pressing the Multifunction button the selected temperature will be stored. The cursor will then jump forwards to the *rotation speed* or (if no rotation speed is available) to the *menu*.

5.2.2 Selection of the rotation speed before operation

The rotation speed can be pre-selected prior to a run with real samples. Select "speed of rotation" from the working menu and confirm the desired value by rotating and then pressing the Multifunction button.

The motor will now start running at the newly adjusted speed. Note, if the new chosen speed is not confirmed within 10 seconds, then the value automatically reverts to the previously stored value. Pushing the "stop" button causes the motor to stop.

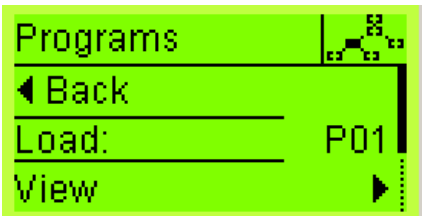
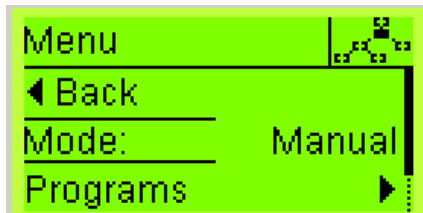
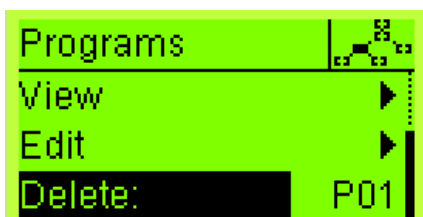
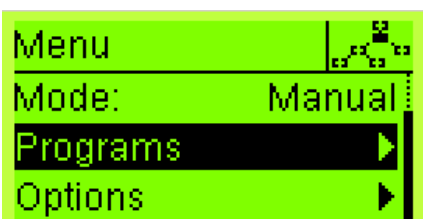

5.2.3 Change/build or delete a program profile in manual working mode.

Even when the instrument is working in *manual mode*, a program can be created, deleted or changed.

Whilst the instrument is in operation, the program points to "load program" and "mode of operation" can not be chosen.

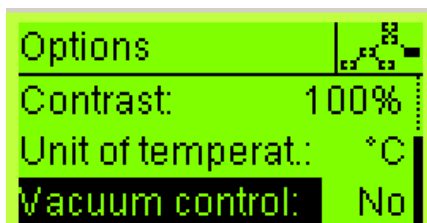
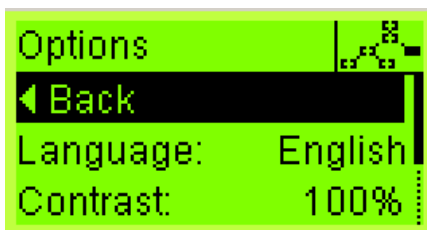

5.2.4 General information about the menu functions:

On the menu item *language* it is possible to choose between the following languages: English, Spanish, Italian, French, German and Japanese.

On the menu item *contrast* it is possible to optimize the display.

On the menu item *temperature* it is possible to choose either Fahrenheit or °Celsius.

On the menu item *Vac. pump* it is possible to switch the vacuum pump on or off directly from the B-585, (Requires Büchi vacuum pump V-500 series with the B-585/V-500 cable). The cable has to be connected at the plug socket in the middle.

5.2.5 Adjusting the working angle of the oven

The working angle of the oven can be adjusted by the release handle.

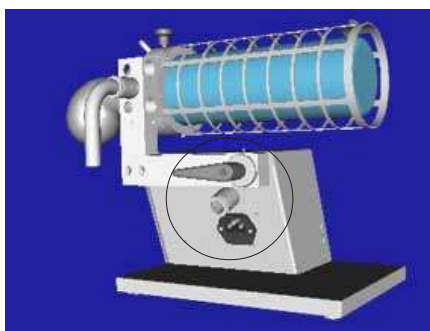

Fig. 9: Angle 3

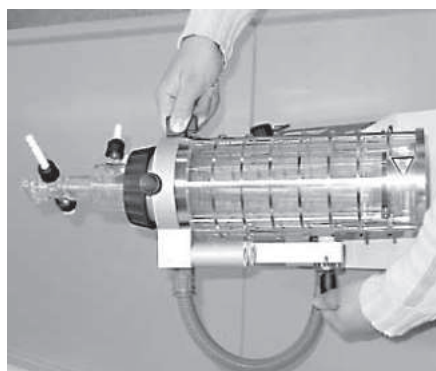
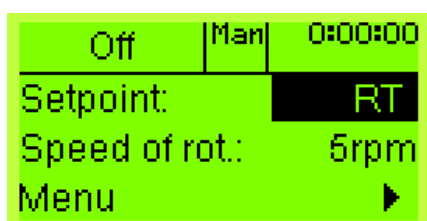
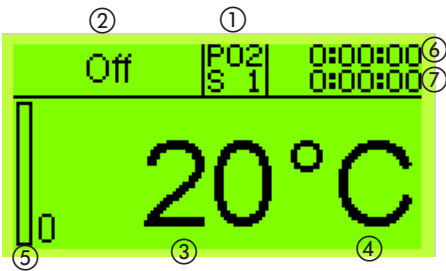

Fig. 10: Working angle



5.2.6 Working at room temperature

To operate at room temperature, select the value "RT" from the Setpoint values. This setting switches the heating circuitry off.



5.2.7 Operation of the B-585 in the program mode

Fundamentals arrangement of the display:

- ① Information about the active mode and current stage of the program (I, II or III)
- ② Operating condition
- ③ Actual temperature
- ④ Temperature unit of measurement
- ⑤ Graphical heating display
- ⑥ Indication of the remaining time to the end of the program
- ⑦ Indication of the remaining time in the current program step

Program load, edit select, delete, view:

By turning the Multifunction button, the display will change to the working menu. By choosing the menu "program" existing programs can be checked, deleted or modified.



To load an existing program, turn the Multifunction button to *load* and confirm it by pressing the button. The cursor will jump to the next selection. By turning the button again the stored programs are shown (P01, P02...) . By pressing the button, the chosen program will be confirmed. Now it shows the working display. To start the chosen program press the green button *start*.

5.2.8 Change or create a program:

If the cursor is on position *change/new*, a new program can be built or an existing program can be changed.

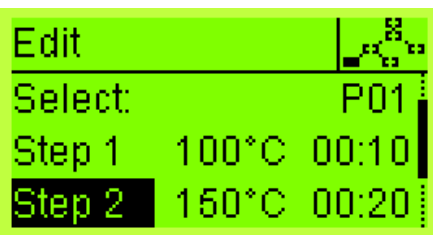

By confirming *choose* the cursor will get to the existing programs. (P01, P03, new.....).

After choosing the program the cursor jumps to *step1* . Pressing the Multifunction button allows the user to change the temperature or time. The cursor jumps to the temperature display. It is now possible to make any desired changes. Press the button to enter the chosen temperature and the cursor will then jump to the time display. Continue accordingly as for the temperature setting.

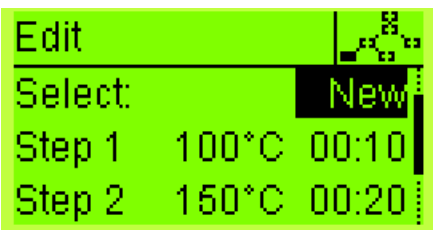

If a new program is created, an empty memory positions are will be offered. **If all of the 10 memory position occupied, then an existing program must be either edited and saved to store the desired parameters, or one must be deleted before a new program can be created and stored.**

At any time, even during a run, any program stored in memory (apart from the one currently loaded), can be edited or deleted. New programs can also be created.

5.3 Operation of the B-585 Drying Oven

Please ensure that the device has been correctly put into operation according to Chapter 4, Putting into operation.

5.3.1 Operational and display elements



Fig. 11: B-585 Drying

- ① Unit sockets with main fuses
- ② Main power switch
- ③ Digital display showing the current temperature
- ④ Multifunction button for setting the desired oven temperature
- ⑤ Pilot lamp, illuminated when heating is turned on
- ⑥ Lever used to open the iris diaphragm
- ⑦ Glass ball cooling apparatus
- ⑧ Holder for the safe contact of the furnace
- ⑨ Start
- ⑩ Stop
- ⑪ Lever of the adjustment of the inclination of the furnace angle

5.3.2 Drying

The glass oven can also be used to dry solid substances. Unlike permanently installed drying cabinets, the drying oven only has to heat up a small volume. It requires less energy, reaches the desired temperature more quickly, and thereby reduces the time for drying. Moreover, if used as a vacuum oven, it has a significantly tighter seal than a drying cabinet and can therefore maintain a better vacuum. There are three methods used for drying direct drying, indirect drying, and rotary drying. The drying accessory is used for direct and indirect drying, the rotary flask for rotary drying.

5.3.3 Filling with the Material to be Dried

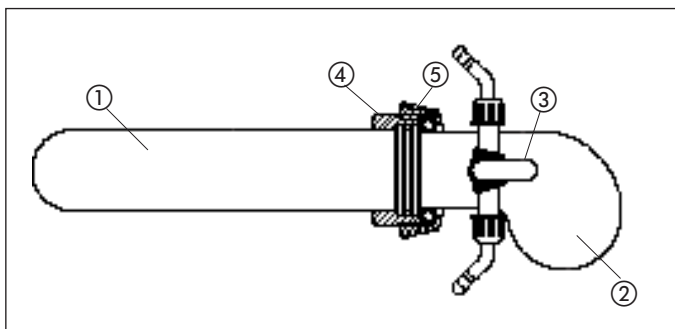

Fig. 12: Direct Drying (A)

The drying accessory consists of three parts. While the drying is in progress, the drying tube (1) into which the product is put (either directly or inside a container), is in the oven. The end cap (2) that catches the moisture evaporated off can be filled with desiccants to improve the drying effect. A stopcock (3) is used to evacuate or aerate the sample chamber. The aluminum flange ring (4) joins the two glass sections in a screwed joint, sealing them vacuum-tight. The flange ring (5) is also used to hold the drying accessory in position within the glass oven. This drying accessory does not rotate.

The material to be dried can be placed in the drying tube in various ways. The method chosen depends mainly on the amount of substance.

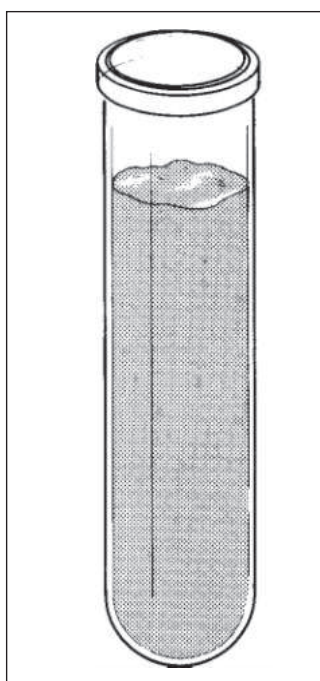

Fig. 13a: Indirect Drying (A)

Example (A)

A large quantity of the material to be dried is placed directly in the drying tube. With this method, existing glass boats, metal dishes, etc., may be used. This drying method should not be used for hygroscopic samples, as these may absorb moisture during transfer to another container after having been dried.

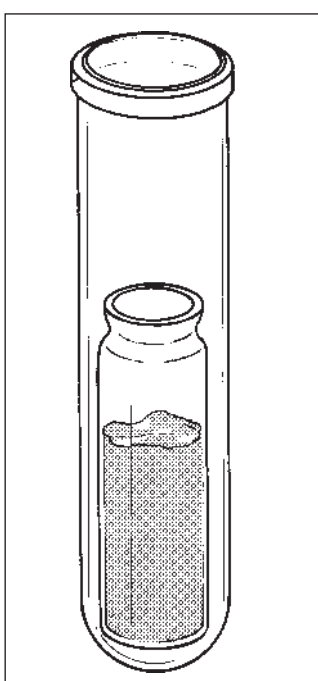

Fig. 13b: Indirect Drying (B)

Example (B)

The material to be dried is placed in its container and the container is placed in the drying tube. The drying oven must be operated in the vertical position for this method. The advantage of this method is that the substance does not need to be transferred from one container to another after drying, and that its container can be sealed immediately after drying.

Example (C)

A hard surface layer is created while drying some substances which increases the drying time dramatically. This can be avoided by rotating the container regularly. It is therefore recommended to use the notched rotation drying flask **which can only be used in conjunction with an electrical ball tube drive.**

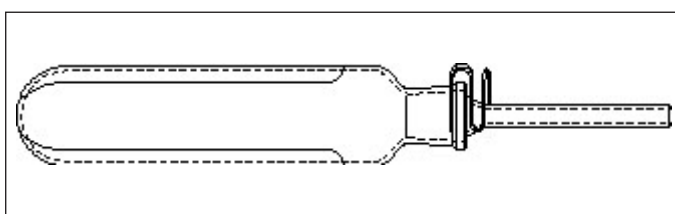

Fig. 14: Rotation Drying Flask (C)



Fig. 15: Drying Tube

5.3.4 Placing the Drying Tube in the Drying Oven

If the material to be dried has been placed in the drying tube according to Chapter 5..., the tube and the end cap are screwed together. The entire assembly is then placed in the drying oven and fastened with the screw ①. You should ensure that the stopcock is vertical and that the reservoir in the end cap is directed downwards.

The oven temperature must be set for drying and, if necessary, the vacuum must be connected. After drying, aeration follows, either using the air in the environment or using an inert protective gas using the corresponding gas connection. The assembly is taken out of the oven and left to air-cool.

5.3.5 Working with Desiccants

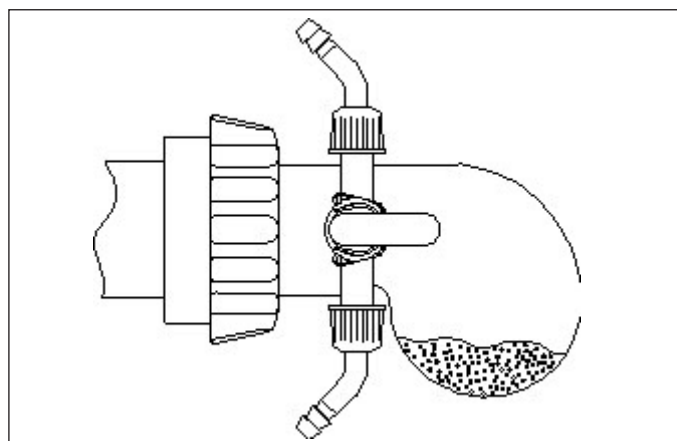

Fig. 16: Desiccant

The drying of substance samples containing water can be accelerated and optimized by using desiccants such as silica gels, CaCl_2 or P_2O_5 . Such desiccants are placed in the rear part of the end cap. When filling with a free-flowing desiccant, you must make sure that the end cap remains clean between the aeration stopcock and the flange. If dust particles adhere to the sides, then the end cap must be cleaned afterwards. Otherwise, there is the danger that of these particles will be taken with the flow of air when aerating the evacuated drying tube, thereby adding impurities to the material to be dried.



The safety guidelines on the original packaging of the P_2O_5 / CaCl_2 should be observed.

5.4 Operation of the B-585 Kugelrohr

Please ensure that the device has been correctly put into operation according to Chapter 4, Putting into operation

5.4.1 Operational and display elements

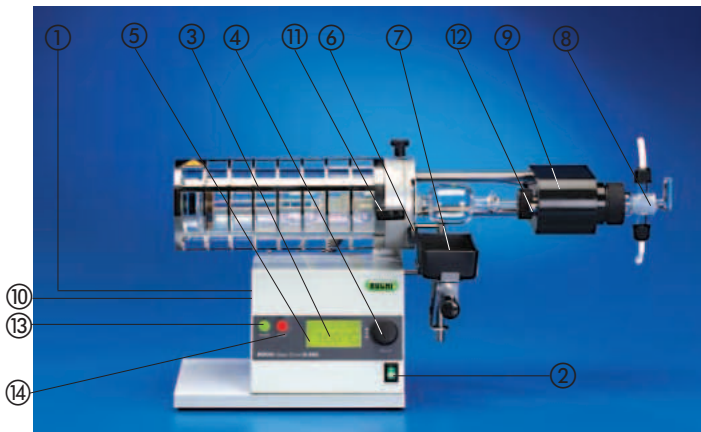

Fig. 17: B-585 Kugelrohr

- ① Unit sockets with main fuses
- ② Main power switch
- ③ Digital display showing the current temperature
- ④ Multifunction button for setting the desired oven temperature and the rotation speed
- ⑤ Pilot display for heating
- ⑥ Lever used to open the iris diaphragm
- ⑦ Glass ball cooling apparatus
- ⑧ Glass cook for aeration
- ⑨ Drive unit for rotating the glass ball
- ⑩ Lever for setting the angle of the oven
- ⑪ Holder for the safe contact of the furnace
- ⑫ Lever for adjusting the vapour duct
- ⑬ Start
- ⑭ Stop

5.4.2 Kugelrohr / Distillation

The glass oven can be used for two types of distillation: single distillation and fractional distillation. The fractional distillation is a bulb to bulb distillation that uses three of four bulbs and bulb cooling. The single distillation may be done either as a bulb to bulb distillation using two bulbs and bulb cooling, or with a condenser with a cooling coil and a collection flask. In this latter application, the glass oven may be viewed as a small rotary evaporator. Common to all three types of distillation is the fact that they all work using the bulb-tube drive. Bulb to bulb distillation uses a tube that consists of as many bulbs as there are components in the mixture.

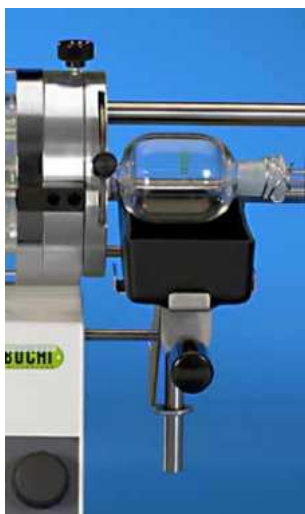

Fig. 18: Cooling device

5.4.3 Cooling

For substances with a low boiling point, air-cooling is not always sufficient to make the vapour condense in the balls outside of the oven area. In this case, it is recommended to use a cooling apparatus. You can fill the dish with tap water, ice-water, an ice-salt mixture, dry ice or a dry ice-alcohol mixture.

The cooling dish is designed so that either a small glass ball can be cooled by turning the dish sideways, or two small or one large glass ball can be cooled by turning the dish lengthwise.



The cooling dish is made of polyethylene. This material is not resistant to chlorinated solvents. For this reason, cooling mixtures containing these types of solvents may not be used. The dish should be prevented from coming into contact with the metal flange.



Dry ice and dry ice-alcohol mixtures will cause injury and burns if they come in contact with skin.

If dry ice-solvent mixtures are used, then there must always be dry ice in the solvent as long as the temperature in the glass oven is higher than 50°C.



Fig. 19 : Assembly/disassembly of the vapor duct

5.4.4 Assembly/disassembly of the vapour duct

The vapour duct is inserted into the drive unit as follows:

The aeration tap, together with the seal, is screwed from the right into the drive unit. The seal should be lightly greased on the sealing side.

The vapour duct with its screw and cone is pushed from the left into the drive unit, such that it passes the seal in the aeration tap on the other side of the drive unit. To tighten the screw of the vapor duct, press the tube adjustment lever down.



Repeat the greasing of the vapour duct if necessary.

5.4.5 Working procedure for a simple distillation

The liquid to be distilled is placed in the vertical glass tube with having only a single ground-glass joint using a pipette.

The glass tube can be filled up to the „max“ mark. The desired number of glass balls are connected to each other and secured against unwanted release with the clips. The ball tube is connected to the vapour duct and pushed into the oven. The aperture is closed and the electrical drive is turned on. The oven temperature is increased until distillation begins. This temperature can be anywhere between 10-40 °C above the sample's boiling point.

If you are distilling in a vacuum, then the ground-glass joints must be lightly greased.

If the user is only interested in the distilled product and not in the residue, the first ball that is sticking out of the oven can be cooled. The platform with cooling dish which is mounted on the device can be used to accomplish this. By connecting the glass stopcock to a vacuum source, the boiling point of thermolabile substances can be suitably reduced.



If the goal of the distillation is the distilled product and not the residual product in the oven, then you should regulate the vacuum and not operate under high vacuum conditions



In order to guarantee the longest possible lifespan of the glass balls, the iris diaphragm aperture should not be closed so tightly that it makes contact with the glass ball or joints when the rotation drive is turned on.

5.4.6 Working procedure for a rough separation of a mixture with several components

Mixtures can be partially separated if the difference in the boiling points between the individual components is fairly large ($> 20\text{C}^\circ$). All of the glass balls are placed in the oven except for the glass ball farthest right. The temperature is increased until distillation begins. The first fraction is caught in the far right ball. If the volume of the first fraction stops increasing, then the distillation of the fraction with the lowest boiling point is complete. The next ball is pulled out of the oven and the temperature is increased again.

When working with thermolabile substance, it is also recommended that the boiling point is lowered by connecting to a suitable vacuum source.

5.4.7 Aeration

After having finished vacuum distillation (position A), the device is turned off and the aeration cock is turned to position B. You may now turn off the vacuum pump. By turning to position C, the distillation chamber is aerated either with the air in the environment or, with the corresponding connection, a safe, inert gas.

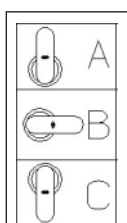

Fig. 20: Aeration stopcock

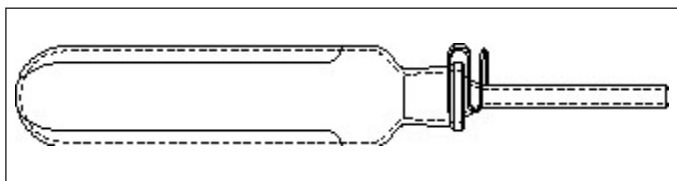

Fig. 21: Rotation drying flask

5.4.8 Working procedure for rotation drying

The vapor duct used for the ball tube distillation must be removed and the vapour duct for rotation drying installed in order to do rotation drying. See Chapter 5.2.3 for information on how to convert the device.

The material to be dried is placed in the drying flask and the tube is connected to the vapour duct. The tube is then placed in the oven and the temperature and speed of rotation are set.

It is also possible here to work under a vacuum.

5.5 Accessories: Sublimation and freeze drying

5.5.1 The sublimation accessory

The vapour pressure of a liquid increases with rising temperature. The same principle applies also to some types of solid materials. Many of them evaporate when warming up without previous liquefaction. This feature is called sublimation. Compounds undergoing sublimation change directly from solid phase to gaseous phase, by-passing the liquid phase. When the gaseous phase is cooled, the liquid phase is again by-passed and the material condenses as a crystalline solid.

The sublimation accessory is inserted into the drying tube (2) instead of the end cover with the bottle connection (1). The solid re-sublimates out on the cooling finger (3), which is cooled with water supplied at the inlet at the side, (4) and removed again at the inlet at the top. A stopcock (5) has been installed to permit evacuation and aeration. Because sublimations are generally carried out under vacuum, care must be taken to see that the O-ring flange gasket (6) has been inserted properly into the holder. Like the drying accessory, the complete sublimation accessory is inserted into the oven.

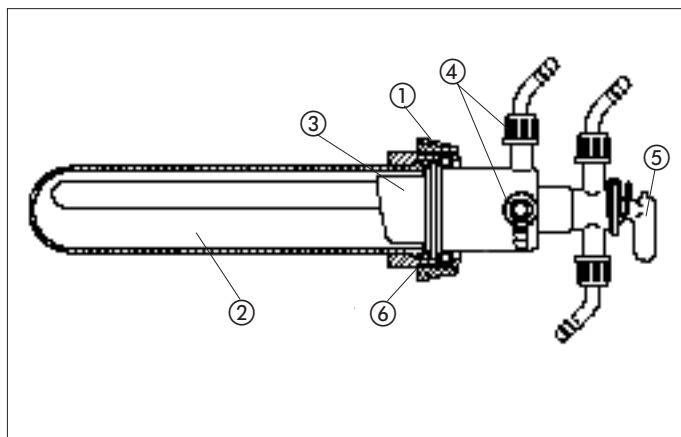

Fig. 22 : Sublimation accessory

5.5.2 Principle of the sublimation

In sublimation, the mixture that is to be cleaned is put into the drying flask and spread out. The cooling finger is then introduced into the drying flask and properly sealed with the flange bolting. When working under vacuum, it is necessary to check that the gasket ring is properly seated in its groove. Next, the sublimation accessory is inserted into the drying oven. The cooling water is connected up and vacuum applied. The inlet and the side should be selected as the cooling water inlet. Sublimation is then started by switching the heater on. The temperature is steadily raised until the substance re-sublimates on the cooling finger. Once sublimation has been completed, the heater is switched off and the flask is aerated. The sublimation accessory is pulled from the oven and cooled. The sublimate can now be removed from the cooling finger.

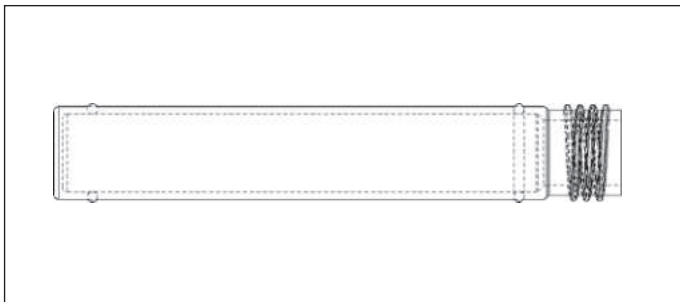

Fig. 23: The freeze drying accessory

5.5.3 The freeze drying accessory

The freeze drying process is a technical procedure for the removal of water. The aqueous solution is cooled down, until it freezes to ice. Now the air pressure over the ice is decreased by connecting a vacuum source, whereby the ice is sublimated from the frozen solution. The dried material can be resolved again in water.

The freezing drying process is the most careful and safest procedure, in order to dry products. The physical phenomenon of sublimation is used.

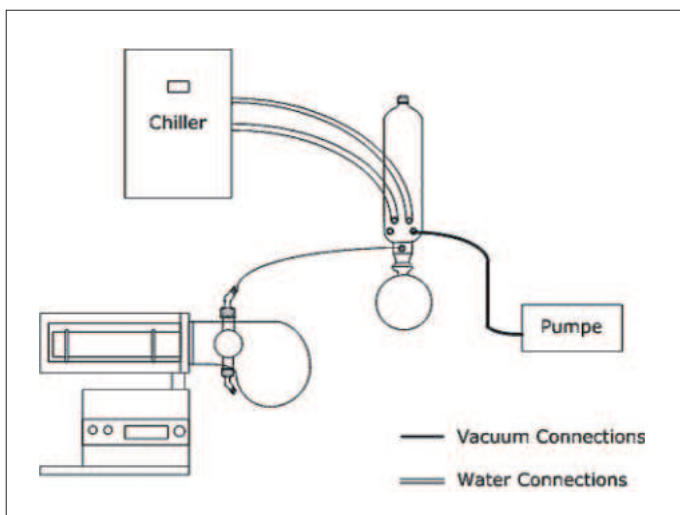

Fig. 24: Scheme of freeze drying

5.5.4 Operation method of freeze drying

The first step of each freeze drying process is the complete freezing of the product which preferably happens in the freeze drying tube.

Before the freezing drying process starts, the system (pump, Chiller) must have reached steady state. The chiller must be cooled down to operation temperature of -30°C to -40°C and the vacuum pump should be warm, before evacuation.

If the samples is in frozen condition in the freeze drying tube, the B-585 is evacuated. The vacuum which can be chosen depends upon the freezing point of the product. Set a vacuum pressure, which ensures a product temperature 10 degrees below the melting point during the drying process.

5.6 Converting the Glass Oven

5.6.1 From the drying configuration to sublimation configuration

With the help of the sublimation accessory samples that sublime onto the cooling finger may be separated from a mixture. For additional cooling of the cooling finger, water can be used. When using cooling water, the upper hose connection should always be used as the water's outlet.

Sublimation processes usually require the use of vacuum. Ensure that the O-ring seal is inserted properly into its groove before the two glass parts are flanged together. Once the sublimation has finished, switch off and leave the instrument to cool down. Pull out the drying accessory and install the flange on the sublimation accessory.



Fig. 25: Glass oven with sublimation accessory

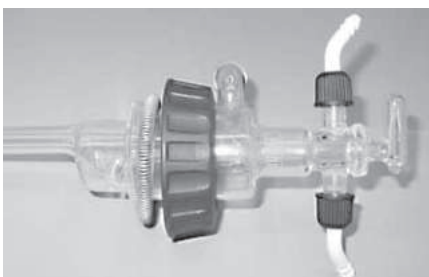

5.6.2 From drying to freeze drying

The freeze drying accessory is immersed into the drying accessory and the vacuum is put on.

5.6.3 From drying configuration to Kugelrohr configuration

First of all switch off the instrument and let it cool down (if it is necessary)

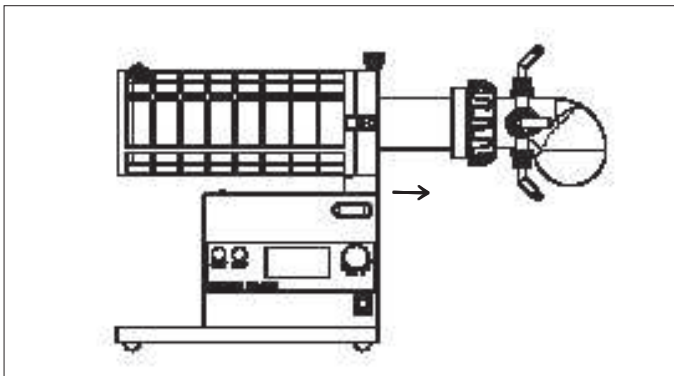

Fig. 26a: Removing drying accessory

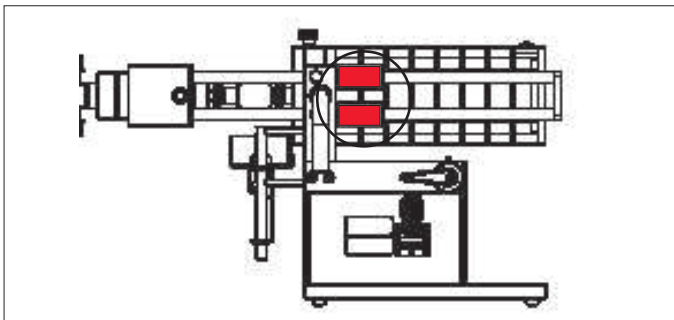

Fig. 26b: Screw on sleeves

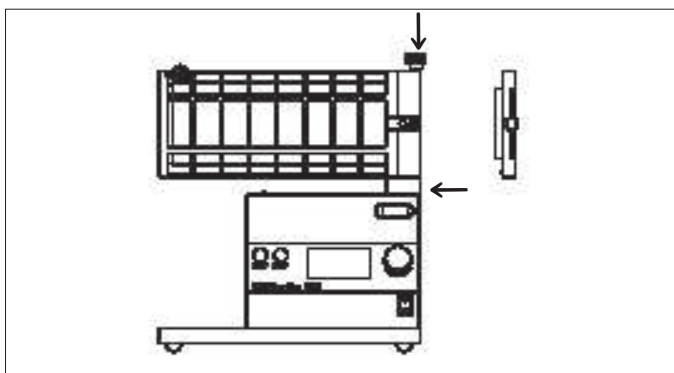

Fig. 26c: Iris diaphragm with fixing screw

The complete drying part has to be removed

- screw in the two sleeves, to facilitate the moving of the drive unit.

- The iris diaphragm can be screwed on

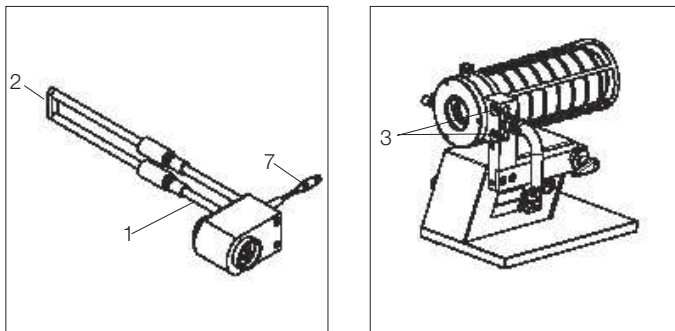

Fig. 26d: Drive unit with sleeves positioned

- To install the drive unit, remove the connection (2) at the end of the rods (1), insert the rods into the openings (3) on the glass oven. Fix up the connection (2) again on the rods.

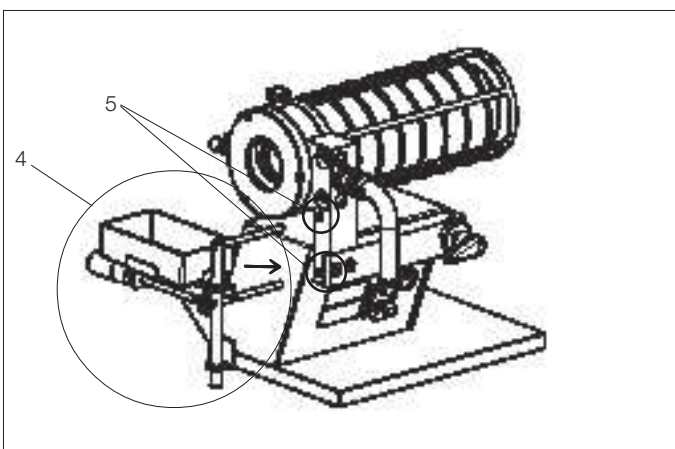

Fig. 26e: Cooling device

- The cooling plate assembly (4) is fastened to the openings (5) in the support frame

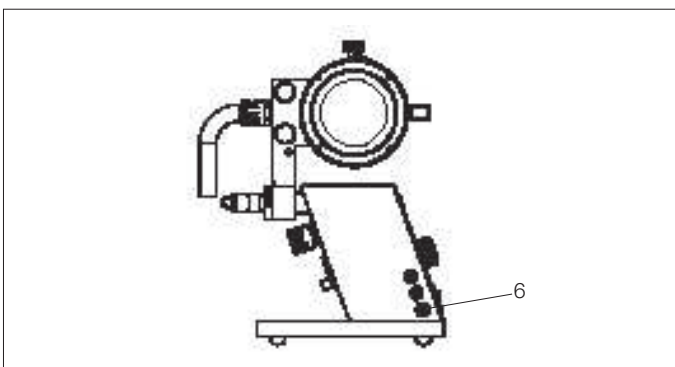

Fig. 26f: Socket for plug in the drive unit

The connection cable (7) for the drive unit has to be plugged into the lower plug socket (6) on the left side of the instrument (drive).

5.6.4 From Kugelrohr configuration to drying configuration

Converting from ball tube distillation to drying is done by following the instructions in Chapter 5.3.2 in the opposite order.

To find out how to operate the drying oven, see Chapter 5.3.

6 Maintenance

All guidelines which are meant to keep the glass oven in working order should be followed. This also includes a periodic cleaning and checking for any visible damage.

6.1 Cleaning



The housing of the B-580 glass oven is coated with paint. Clean only with dry rag or a rag moistened with alcohol.

While cleaning the oven, you should make sure that the iris diaphragm does not become dirty.

The inner oven space is best cleaned with a moist rag. Any kind of solvent may be used to do so.



Never rinse the oven out with running water or wash it using a lot of water. Water could get between the outer and inner glass layers where the heater is and cause an electrical short circuit. If water should accidentally get in the iris diaphragm, you should dry it out by placing the entire oven in a vacuum (vacuum drying cabinet) at 40°C for several hours before you start using it again.

6.2 Service

The service of the device is limited to the ball tube drive, in which the vacuum gasket and the rubber seal in the GL 14 may leak after prolonged usage.

6.3 Customer service

The device may only be serviced by authorized service personnel. Such persons will have undergone fundamental technical training and have knowledge of the hazards associated with not following the safety precautions. Büchi customer service centres have device-specific service instructions which can only be obtained by authorized personnel.

The addresses of the official Büchi customer service centres can be found on the back cover of these instructions. Contact one of these locations in case you encounter malfunctions or if you have technical questions, or application-specific problems.

The Customer Service Department of the Büchi company is available for the following services:

- Replacement parts (please use the part numbers listed in the replacement parts list in the Appendix)
- Repair services
- Maintenance services
- Technical consulting

7 Taking out of operation



- | The device must be cooled down and thoroughly cleaned.

7.1 Storage/Transport

The device must be stored and transported in the original packaging, and must be thoroughly clean.

7.2 Disposal

To dispose of the glass oven in an environmentally friendly manner, you will find a list of the materials of all major parts in Chapter 9, Appendix. This guarantees that you can separate the parts for recycling. To dispose of electrical parts, refer to the appropriate guidelines. You also must observe the regional and local laws regarding disposal.

8 Replacement parts

Only original replacement parts that guarantee the safe use and functionality of the device. The use of replacement parts and supplies other than Büchi replacement parts and supplies is only allowed with the consent of the manufacturer. For assembly and disassembly purposes, replacement parts may only be used according to the descriptions in Chapter 6, Maintenance. The manufacturing of this product, as described in these instructions, is prohibited.

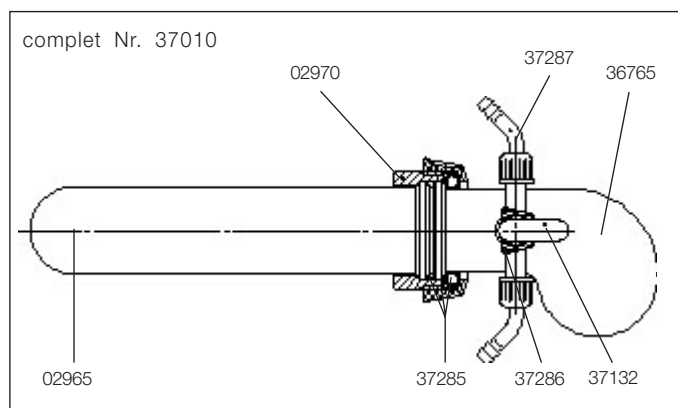

Fig. 27: Drying unit complete

8.1 B-585 Drying configuration replacement parts

Drying accessory complete	37010
Drying tube	02965
Flange ring	02970
10 Device fuses 3,15 AT	19659
End cap for drying	36765
Stopcock	37132
Set compr. Flange screw, spring and flange seal	37285
Set STJ clips (12 pieces)	37286
Set hose nipples GL 14 (4 pieces)	37287

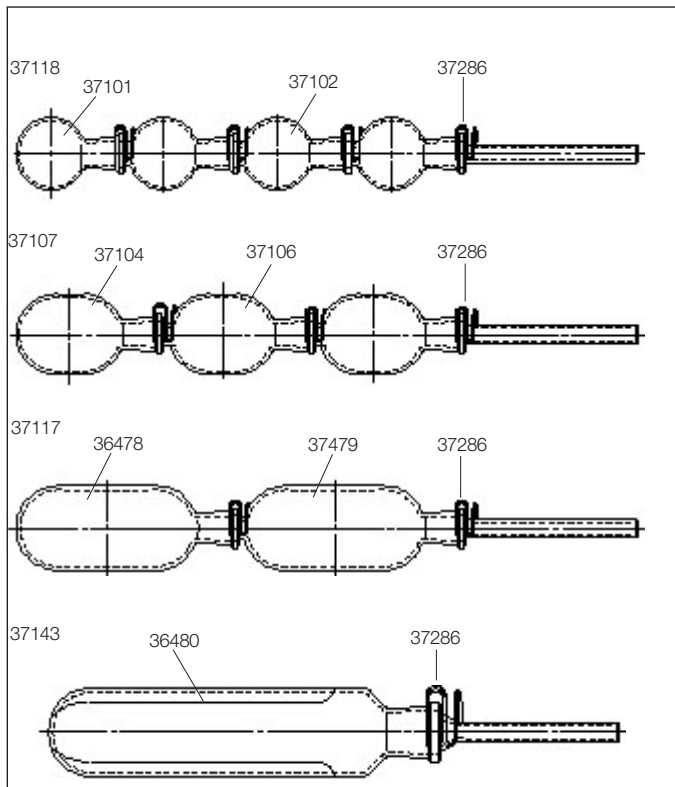

Fig. 28: Kugelrohr

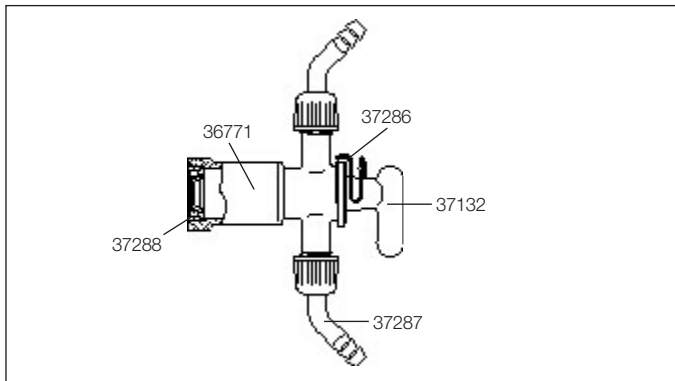

Fig. 29: Hose connection assembly with stopcock

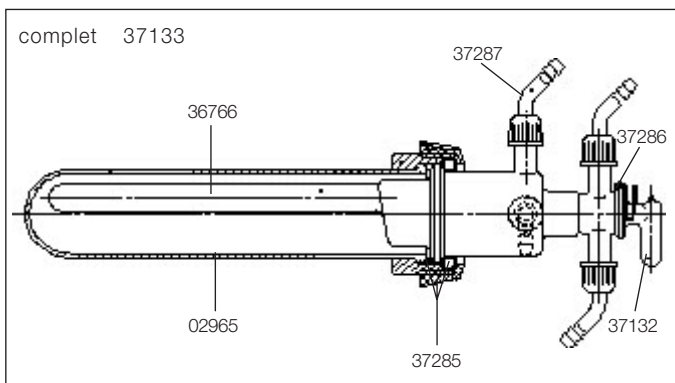

Fig. 30: Sublimation accessory complet

8.2 B-585 Kugelrohr configuration replacement parts

Description	Order Code
10ml ball tube (Ns 14.5/23) with vapour duct and clips	37118
20ml ball tube (Ns 14.5/23) with vapour duct and clips	37107
40ml ball tube (Ns 14.5/23) with vapour duct and clips	37117
Rotation drying flask with vapour duct and clip	37143

Communication cable B-585/V-5xx	46728
10 Device fuses 3,15 AT	19659
Connection piece	36771
Stopcock	37132
Cooling dish	37152
Set STJ (12 pieces)	37286
Set hose nipples GL14 (4 pieces)	37287
Set vacuum gaskets (5 pieces)	37288

8.3 Sublimation accessory replacement parts

Complete sublimation accessory	37133
Drying tube	02965
Flange ring	02970
Sublimation insert	36766
Cock	37132
Set flange screw, spring, gasket	37285
Set STJ (12 pieces)	37286
Set hose nipples GL14 (4 pieces)	37287

9 Appendix

9.1 Technical data

Supply voltage		100 - 230 VAC +/-10 %
Frequency		50/60 Hz
Power		max. 450 W
Pin assignment	Pin 1: Pin 2: Pin 3 to 8:	Ground (Gnd) + 24 V DC not assigned
Warm-up time		ca. 10 min. (from 20°C to 300°C)
Temperature regulation range		40-300°C
Temperature accuracy		+/- 5°C (in the middle of the oven at 300°C)
Drying	Drying volume Dimensions Weight	max. 100-250 ml 410 x 300 x 300 (width x depth x height) 9.5 kg
Kugelrohr	Distillation volume Rotational speed Dimensions Weight	max. 10-60 ml 0-50 rpm. 650 x 300 x 300 (width x depth x height) 11.5 kg
Ambient temperature		5-40°C
Installation / overvoltage category		II
Pollution degree		2
Environmental conditions		for indoor use only maximum relativ humidity 80% for temperatures up to 30°C decreasin linearly to 50% relative humidity at 40°C

9.2 Error messages

Error message	Possible cause	Remedy
Main switch does not light up	Device is turned off, power supply voltage is missing or fuse defective	Switch on the device, check power supply voltage and fuses
No temperature indication	Display or print defective	Check power supply voltage/fuses and replace them, send device to service center
Oven does not heat	No power supply voltage or fuses defective	Check heating lead,
Motor does not turn	Device is turned off, no mains voltage or fuses defective, motor set is on 0 r/min, control cable is not plugged in properly,	Switch on the instrument, check the control cable, please contact the service department
E1	Internal temperature sensor defective	Please contact service department
E2	Internal temperature sensor defective	Please contact service department
E3	Internal temperature sensor defective	Please contact service department
E9	Heating defective	Please contact service department
E10-11	Heating defective	Please contact service department

9.3 Materials used

Description	Materials	Material code
Housing	Steel sheet metal	ST 12
Heating tube	Borosilicate glass	
Glass jacket tube	Borosilicate glass	
Cooling dish	Hard-polyethylene	HD-PE
Heater fixture (site)	Aluminium	ALMGSI 1
Kugelrohr-Insert	Aluminium	ALMGSI 1
Kugelrohr-housing	Polyacetal	POM
Heating flange	Aluminium	ALMGSI 1

9.4 Declaration of conformance

We

BÜCHI Labortechnik AG
Postfach, CH-9230 Flawil
Switzerland

declare under our sole responsibility that the product:

BÜCHI Glass Oven **B-585**

to which this declaration relates is in conformity with the following standards:

EN 61010-1: 2002

Safety requirements for electrical equipment for measurement control laboratory use: General requirements

EN 61326: 2002

Electrical Equipment for measurement, control and laboratory use-
EMV requirements

EN 61000-3-2: 2000

Limits for harmonic current emissions

EN 61000-3-3: 1995

Limitation of voltage fluctuations and flicker

following the provisions of EU-Directive:

Directive 73/23/EEC

Directive 89/336/EEC

Flawil, 18.05.2004

BÜCHI Labortechnik AG
Meierseggstrasse 40
9230 Flawil
Schweiz

Tel +41 (0)71 394 63 63

Fax +41 (0)71 394 65 65

buchi@buchi.com

www.buchi.com



Guido Worch
Quality Manager

