

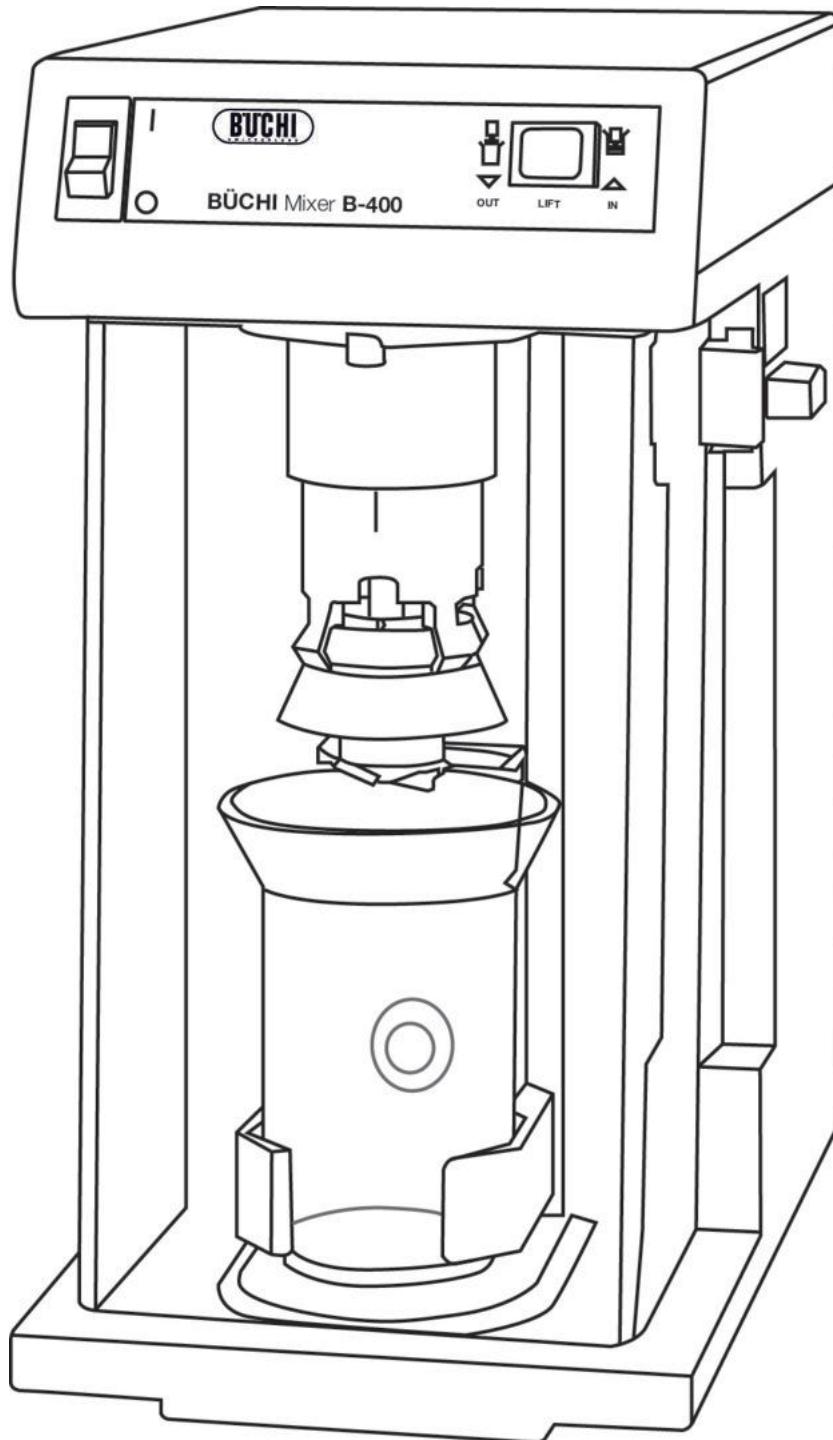

Mixer B-400 Operation Manual



Imprint

Product Identification:
Operation Manual (Original) Mixer B-400
096541

Publication date: 05.2018

BÜCHI Labortechnik AG
Meierseggrasse 40
Postfach
CH-9230 Flawil 1

E-Mail: quality@buchi.com

BÜCHI reserves the right to make changes to the manual as deemed necessary in the light of experience, especially with respect to structure, illustrations and technical details.

This manual is copyrighted. Information from it may neither be reproduced, distributed, or used for competitive purposes, nor made available to third parties. The manufacture of any component with the aid of this manual without prior written agreement is also prohibited.

Contents

Contents	3
1 Scope of delivery	4
2 Safety	5
3 Function	8
4 Putting into operation	10
5 Operation	11
6 Maintenance	12
7 Taking out of operation	16
8 Replacement parts	17
9 Appendix	19



Read these instructions carefully before you use the BUCHI Mixer **B-400**. Keep the instructions in a safe place close to the Mixer for quick reference whenever required.

Chapter 2 contains important notes concerning safety. Read these notes to operate the Mixer safely.

Subject to change without prior notification. No part of these instructions may be processed, duplicated or distributed by electronic or optical means without the written permission of BÜCHILabortechnik AG. All rights reserved. Copyright© BÜCHILabortechnik AG, 1995

EN Version F (22 pages)

Order No.

B-400 Instructions

096541



LAB Online Exhibition



1 Scope of delivery



Figure 1: General view



Figure 2: Enclosed items

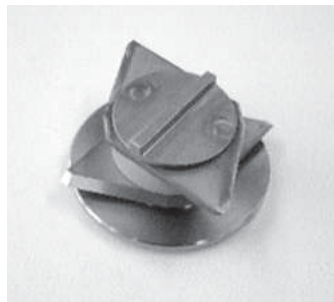

Figure 3: Cutter



Figure 4: Diaphragm seal

Designation

Order No.

Models:

Version with steel cutter	50 Hz	34220
Version with steel cutter	60 Hz	34325
Version with ceramic cutter	50 Hz	34239
Version with ceramic cutter	60 Hz	34327

Enclosed items:

1 Sample beaker	26441
1 Cutter key	34225
1 Power cable of the following types:	
Type CH	10021
Type Schuko	10029
Type GB	17833
Type AUS	17834
Type USA	33756
1 Instructions in the following languages:	
German	096540
English	096541
French	096542
Italian	096543
Spanish	096544
1 Packaging	34447

Optional accessories:

Cutter, complete	
Steel upper	36913
Steel lower	36914
Ceramic upper	36915
Ceramic lower	36916
Diaphragm seal (Polyvinylidenfluorid)	36912
List of applications	
German	97661
English	97662

Table 1: Scope of delivery

2 Safety

The Mixer complies with the state of engineering and the recognized rules of safety.

Please note:

- it should be used by persons with sufficient training
- it should be used for purposes for which it is intended.

Symbols



Stop

Information about hazards which can lead to serious material damage and cause serious fatal injury.



Warning

Information about hazards which can lead to material damage and be harmful to your health.



Please note

Ignoring information about technical requirements can lead to malfunctions, inefficiency and lost production.

Requirements to be met by the customer

The Mixer must be operated by laboratory personnel who understand the hazards that can arise when using the Mixer. These instructions should be read by all personnel prior to the use of this Mixer.

Proper use

The Mixer is designed and built for laboratory service. It is intended to be used as a disintegrating and mixing machine for laboratory samples.

The Mixer is used for:

- the disintegration and simultaneous mixing of samples with a high water, fat or fiber content
- the preparation of samples for trace element analysis.

Practical examples of applications with accompanying notes can be found in Section 5, Operating the Mixer. For the Mixer to be used properly, it must be cleaned and handled carefully as outlined in these instructions.

Improper use

The customer is responsible for any damage due to any use other than those already listed or any application that does not conform with the technical data.

The following applications are prohibited:

- Use of organic solvents.
- Samples of hard and brittle materials (e.g. soil samples, hard grains, sandy samples...) that can wear down the cutter too quickly, break the beaker or damage the diaphragm seal.
- Hard, deep-frozen samples.
- Preparation of food prior to human or animal consumption
- Samples that may explode and ignite when subjected to impact, friction, heat or sparking (e.g. explosives, ...).



Substances which may lead to spontaneous reactions or explosions by impact, friction, heat or sparking are strictly prohibited.

General hazards

Hazards arise generally

- from the two sharp blades rotating at very high speed.
- from replacing the cutter
- from extreme vibrations caused by imbalance due to improper use
- from unsuitable sample material (risk of fire or explosion).



You are allowed to install and remove only those specific parts of the Mixer that are so designed to enable it to perform its function. To do so, you should use the tool supplied with the Mixer. Apart from authorized maintenance personnel, no one is allowed to use standard tools to remove any safety devices and covers. The Mixer should be turned off and unplugged when replacing parts!

Safety measures

The **guard door** must always be closed to operate the Mixer. After the door latches into position, turn the safety catch fully clockwise until it stops.

There is a risk of injury when replacing and handling the sharp cutter. To reduce the risk, you should wear suitable **gloves** and use the special tool.

Depending on the sample material in question it may be necessary to wear additional personal safety items such as **goggles** or a laboratory coat.

The customer shall be responsible for **instructing** personnel. These instructions are to be considered a part of the Mixer and should always be kept with it so that operating personnel can consult them at any time. The instructions can be ordered in other languages.

The customer shall notify the manufacturer immediately of any **concerns about safe operation**.

Modifications are only permitted after consulting with the manufacturer and obtaining written consent.

Regional and local **laws and regulations** should be observed.

Safety elements

The Mixer can only be operated with the safety door closed. Opening the door while the Mixer is in operation will cause it to stop. When this happens, the rotating cutter is quickly decelerated.

For the Mixer to function, the rocker button must be kept pressed.

If the resistance of the material in the beaker causes the speed to drop sharply, the beaker and its contents are moved away from the cutter to prevent possible breakage. Once the required speed is reached again, the beaker plus contents are moved back to the cutter.

The power switch also acts as a motor overload or cut-out.

Please read the description in Section 4, Putting into operation.

3 Function

The process is based on the **simultaneous** disintegration and mixing of sample materials with volumetric reduction, using two high-speed blades in a beaker.

The materials used are also suitable for the purposes of **trace element analysis**. In this case you should consult the matrix of materials in Section 9, Appendix.

Starting point: Sample material in the beaker, the beaker in position, the safety door closed.

- Beaker plus contents move up to the cutter.
- As soon as the whole cutter is inside the beaker, it begins to rotate.
- When the cutter reaches maximum speed, the beaker plus contents move up to the cutter.
- The membrane pressure automatically accommodates the sample volume.
- The sample is disintegrated and mixed simultaneously.
- The beaker plus contents moves down far enough for the cutter to coast to a stop while inside the beaker.
- The beaker plus contents moves down away from the cutter.

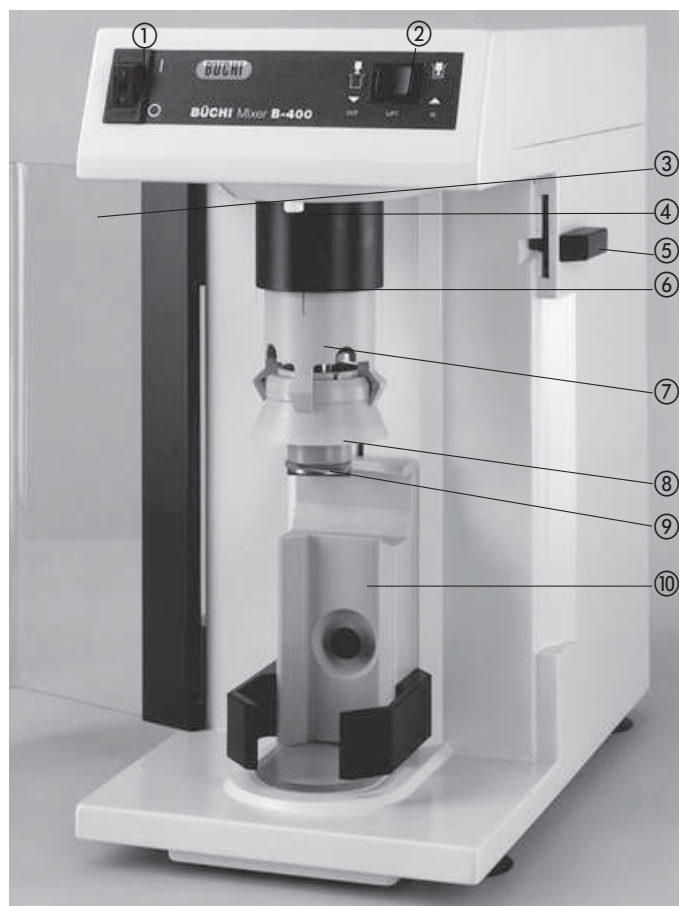

Position of the controls and indicators

- ① Power switch
- ② Rocker button
- ③ Guard door
- ④ Shaft lock button
- ⑤ Door latch
- ⑥ Cover
- ⑦ Diaphragm seal holder
- ⑧ Diaphragm seal
- ⑨ Cutter, complete
- ⑩ Glass holder, complete

Figure 5: Positions and designations of the Mixer's controls and indicators

Function of the controls and indicators

Power switch ①

Switching the Mixer on and off. A bimetal switch cuts the circuit if the line is overloaded in excess of 12A. In this case the power switch is moved automatically into zero position.

Switch on the Mixer and it will be ready for operation again.

Rocker button ②

If you press the rocker button to the right (IN) and keep it pressed, the beaker will move up to the cutter. If you release the rocker button, the beaker will move down but the cutter will remain inside the beaker.

If you press the rocker button to the left (OUT) and keep it pressed, the beaker will move down.

Guard door ③

The Mixer only works when the guard door is closed. The door latch ⑤ is locked by turning to the rear (in clockwise direction) and is opened by turning to the front (counter-clockwise direction).

4 Putting into operation

Unpacking

The Mixer has adhesive rubber feet, so it is best to place it on a firm, clean and level surface.

Keep the original packaging in a safe place in case you ever want to move the Mixer.

Power connections

Always connect the Mixer up to a grounded or earthed socket and outlet. External couplings and extension cables must incorporate a protective conductor (3-pole couplings, cables and plug-and-socket devices). The protective conductor must never be interrupted under any circumstances.

Check that the voltage of the socket-outlet corresponds to the value marked on the rating plate.

Preparing the diaphragm seal for first-time use

Fill the sample beaker up to the blue mark ① with warm water and insert in the mixer. Start the mixing cycle and allow to run for 10 seconds.



Follow this procedure whenever you use a diaphragm seal for the first time. This will prolong the life of the diaphragm seal.



Never put the mixer into operation without any sample material. Dry running can result in the destruction of the diaphragm seal.

5 Operation

Adjustments



Switch off the Mixer at the power switch if it makes any unusual noises or shows signs of instability. Check whether all the parts and particularly the two blades are in position and have been correctly installed (see Section 6, Maintenance).

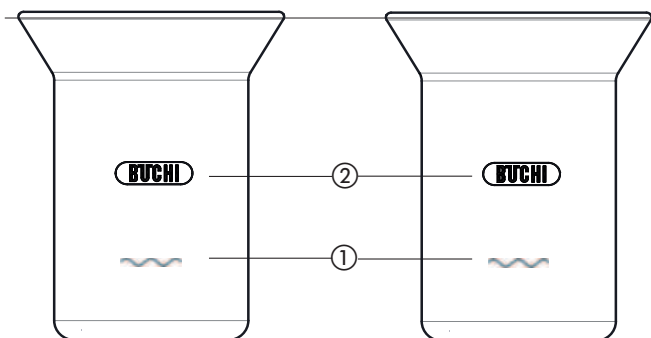

Figure 6: Sample beakers

Procedure

The recommended **sample weight** (see the list of application in Chapter 9, Appendix) must be observed when you fill sample material in the beaker.

Please note the following points:

- Never fill pieces of sample material to a level higher than the green mark ②.
- Never process samples which do not comply with the mixer's intended use (Chapter 2, Safety).
- Never put the mixer into operation without any sample material.



Figure 7: Inserting the sample beaker

Push the beaker over the diaphragm seal from underneath and place in the beaker holder. See Chapter 6, Maintenance, for details of how to fit the diaphragm seal holder, the cover and the cutter.

Close the guard door.

Keep the rocker button pressed to the right (IN) to start the dis-integrating and mixing cycle.

Keep the rocker button pressed to the left (OUT) to move the beaker away from the cutter.

See Chapter 6, Maintenance, for details concerning dismantling, cleaning and assembly.

Malfunctions

Malfunction	Possible cause	Remedy
Mixer performs no function	Mixer not switched on	Plug in cable
	Power switch off	Turn switch on
	Door not closed	Close door
	Fuse F101 on print GS-1 defective	Call technical customer service
Beaker holder does not move up	Fuse F102 on print GS-1 defective	Call technical customer service
Beaker holder does not move up far enough	Sensor print GS-2 is in wrong position	Call technical customer service
	Magnet/Hall sensor out of position on shaft	Call technical customer service
Cutter rotates although rocker button is not pressed	Semiconductor relay on print GS-1 defective	Call technical customer service

Table 2: Malfunctions

6 Maintenance



Wear gloves and use the supplied tool when changing the cutter!
The blades are very sharp and dangerous!

Cleaning

After use, fill the beaker with water up to the bottom mark ① (see Chapter 5, Operation) and insert in the Mixer. Start the mixing process. If necessary, repeat with clean water.

To clean the Mixer thoroughly you must first switch it off and disconnect from the power supply. Remove the cutter, the diaphragm seal, the diaphragm seal holder and the cover, clean with water and dry.

Fitting and dismantling the cutter



The rotating parts run at such high operating speeds that you must be particularly careful when replacing the cutter. Failure to observe the following points may lead to imbalance and have grave consequences.

- Always fit two blades.
- Have the blades resharpened only by the manufacturer; never use blades made of different materials.
- When you install the cover etc., follow the instructions described in this chapter. When you reinsert the beaker holder, make sure it sits firmly.

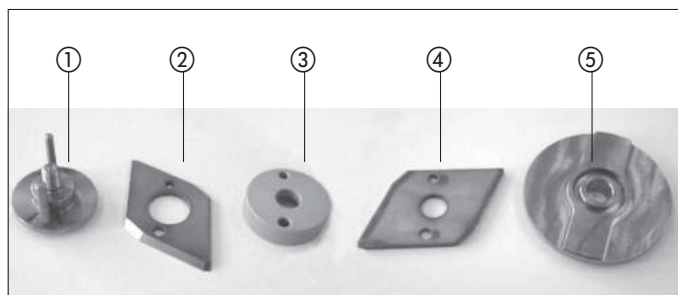

Figure 8: Fitting and dismantling the cutter

Cutter set:

- ① Cutter screw
- ② Bottom blade
- ③ Spacer
- ④ Top blade
- ⑤ Displacement disk

Parts 1–5 must be assembled in the order stated. The cutter set is designed so that it cannot be assembled incorrectly. Use the supplied key to screw the cutter in the drive shaft.

Use the same tool to dismantle the cutter. After having blocked the shaft with the shaft lock button, you can release the cutter.



Figure 9: A leaking diaphragm seal



Figure 10: Flattening the diaphragm seal

Fitting and dismantling the diaphragm seal

The diaphragm seal is fitted by pushing and removed by pulling. No tools are required but the cutter must be dismantled first. Take care not to deform or damage the sealing lips and make sure that the positioning lug ① does not get caught under the holding clip.

Leaking diaphragm seal

The diaphragm seal is not absolutely leak-proof. If its sealing effect deteriorates, it can be dismantled and flattened again with a little pressure.



The diaphragm seal is a wearing part that needs to be replaced from time to time.



When you use a diaphragm seal for the first time, fill the sample beaker up to the blue mark ① (see Chapter 5, Operation) with warm water and insert in the mixer. Start the mixing cycle and allow to run for 10 seconds. This will prolong the life of the diaphragm seal.

Fitting and dismantling the diaphragm seal holder and the cover

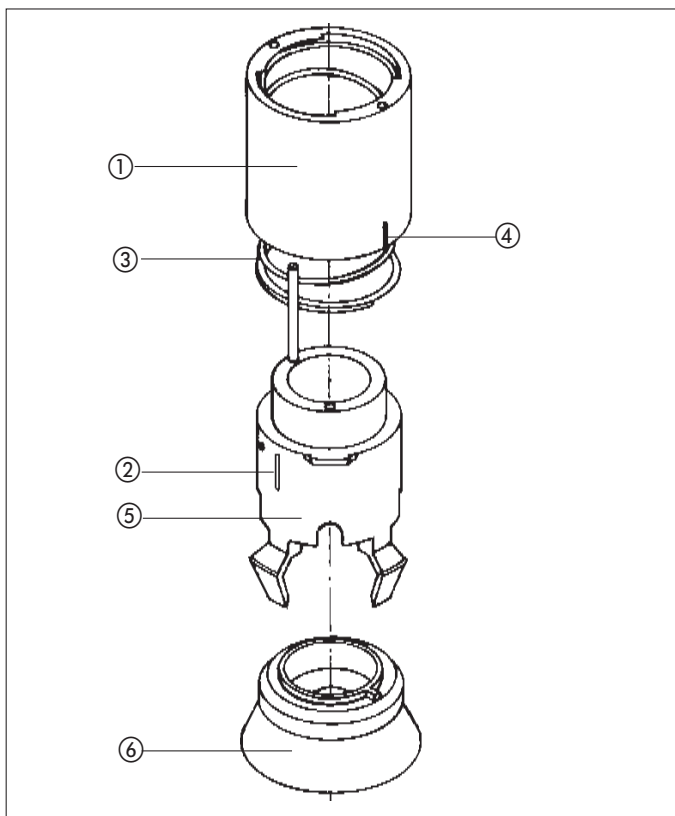

Figure 11: Drawing of the cover

1. Insert the spring ③ in the cover ①.
2. Connect the cover ① to the holder ⑤.
3. Align the mark on the holder ⑤ with the mark ④ on the cover ①.
4. Connect the two parts by pressing and turning to the left simultaneously.
5. Align the two marks ② + ④.
6. Move the marks ② + ④ so that they face the front.
7. Move the cover ① over the shaft.
8. Latch the cover ① in place by pressing and turning to the right simultaneously.
9. The membrane ⑥ is pressed gently into the holder ⑤.

Take care not to deform or damage the sealing lips and make sure that the positioning lug ① does not get caught under the holding clip.



Figure 12: Beaker holder

Running direction of
the cutter

Fitting and dismantling the beaker holder

Pull out button ①, press the beaker holder up and pull it out.

To fit the beaker holder, slide it into the rail and press down until button ① clicks into place.

Compulsory inspection and maintenance

All regulations aimed at keeping the Mixer in good working order must be observed. They include cleaning the Mixer at regular intervals and examining it for any signs of damage. Each time the Mixer is repaired, the customer must first make sure that it only works when the guard door is closed. He must then check that the cutter is decelerated automatically when the process is completed, and that the cutter runs in the proper direction (see Figure 13).

Maintenance of the drive spindle



From 1st Jan. 1996 all B-400 mixers will be supplied with a CTV spindle nut. The spindle nut enables the drive spindle to be used without maintenance, so it must not be lubricated.

Replacement of the driving belt for raising / lowering

Remove the rear panel of the apparatus. From outside, insert a Pozidrive screwdriver (screwdriver for recessed-head screws) through the holes in the bottom of the apparatus and loosen both the screws in the drive motor retaining plate. Place the new belt over the driving pulleys and tension it by means of the retaining plate. 5mm of slack is allowed for the belt between the belt pulleys. Then retighten the two retaining plate screws.

Technical customer service

Request for repair assistance

Only factory authorized service technicians are allowed to completely disassemble the Mixer.

The addresses of BUCHI customer service centers are listed on the back cover of these instructions. Please contact these centers if you have any technical questions, problems with an application or trouble with your Mixer.

Service manuals are available from the BUCHI customer service centers.

7 Taking out of operation



The Mixer must be emptied of any harmful substances and cleaned thoroughly (Chapter 6, Maintenance). This will eliminate the possibility of persons suffering injury from harmful materials.

Storage/Transportation

The Mixer should be stored and transported in its original packaging.

With its adhesive rubber feet the Mixer displays a very strong grip. It is therefore advisable to tip the Mixer slightly to the side before attempting to lift it.

Disposal

To help you dispose of the Mixer in as environment-friendly a way as possible, we have listed the materials (with material codes) of the main components in Chapter 9, Appendix, Table 5. You are thus able to sort the parts accordingly for recycling. We wish to point out that there are special guidelines in force for the disposal of electronic components. It is also necessary to observe regional and local laws.

8 Replacement parts

The following replacement parts may only be used in conjunction with Chapter 6 of these instructions for fitting and dismantling purposes. The Mixer's operational safety and serviceability are only guaranteed by **original BUCHI accessories**. The use of other makes of replacement parts and accessories is only permitted after consulting with and receiving written approval from BÜCHI Labortechnik AG or from a BUCHI factory authorized service center.

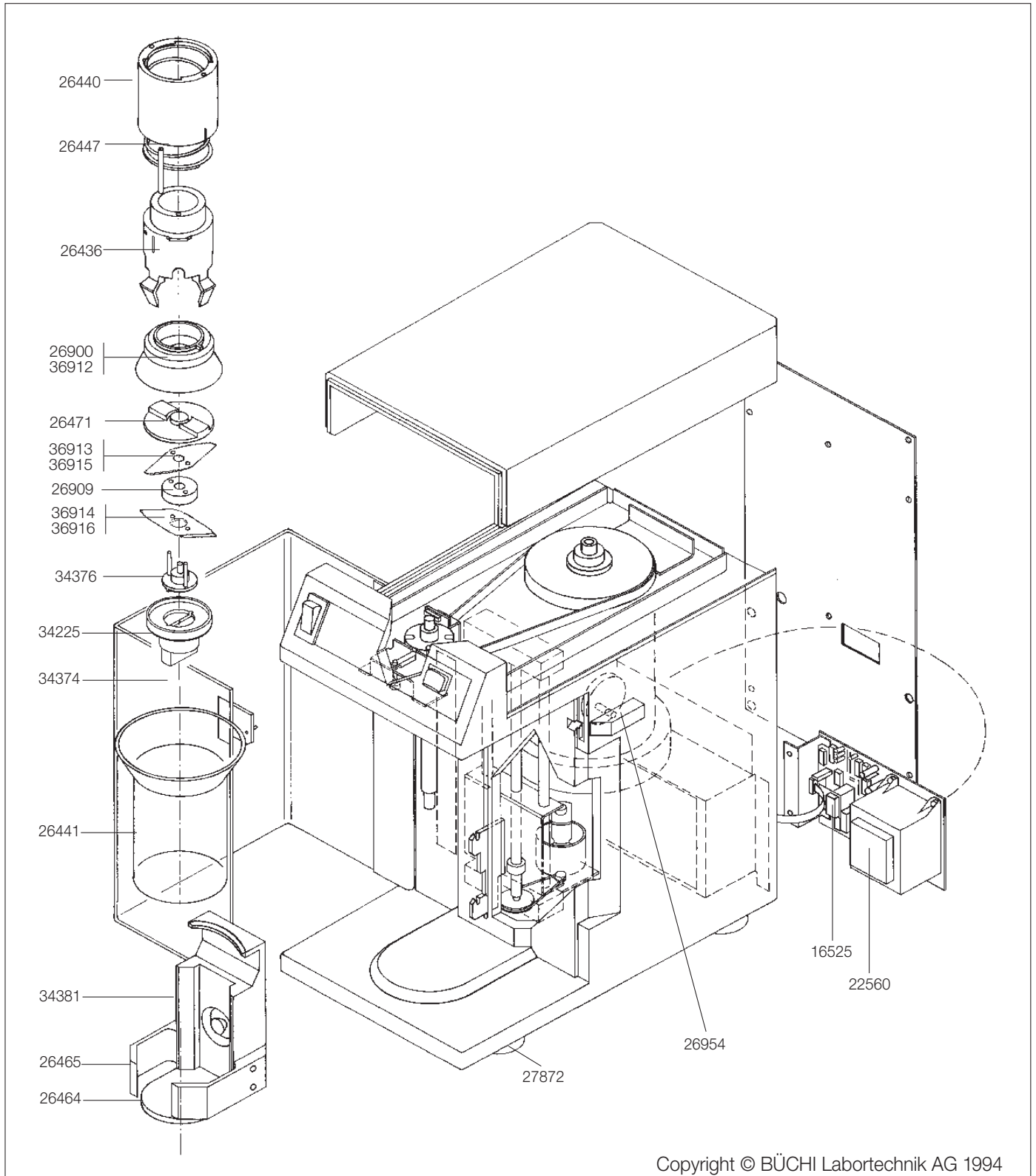

Figure 13: Exploded drawing of the Mixer

Copyright © BÜCHI Labortechnik AG 1994

Order No.	Item
34376	Cutter screw, titanium
26909	Spacer, PEEK
26471	Displacement disk, titanium
26900	Diaphragm seal
26436	Diaphragm seal holder
26447	Spring, D=65/3.2, L=97
26441	Sample beaker
34381	Beaker holder, complete
26465	Beaker clip
26464	Beaker holder bottom
27872	Rubber feet
26954	Knob for latch
34374	Guard door, complete
34225	Tool for cutter
26440	Cover
16525	Fuse 250mA, slow (10 pcs)
22560	Fuse 2.5A, slow (10 pcs)
36913	Top blade, steel
36914	Bottom blade, steel
36915	Top blade, ceramic
36916	Bottom blade, ceramic

Table 3: Replacement parts

9 Appendix

Technical data

Mixer dimensions (width x height x depth)	300 x 510 x 530 mm
Package dimensions (width x height x depth)	400 x 640 x 580 mm
Weight (net)	26 kg
Weight (gross)	32 kg
Mains connection	3 wire power cable
Voltage	200–240 V
Frequencies (2 variants)	50 Hz 60 Hz
Power consumption	max. 2100 W
Current consumption	approx. 10 A
Hardness	
Blade made of steel	~800 Vickers
Blade made of titanium	~1400 Vickers
Blade made of ceramic	~1750 Vickers
Sample quantity	Depends on consistency and volume; see Application List
Max. cycle time	30 s
Interval between 2 cycles	90 s
Temperature limits	
In operation	5 to 40° C
In storage	5 to 40° C
Relative humidity	
In operation	80 % rH up to 31° C / 50% rH up to 40° C
In storage	65 % rH

Table 4: Technical data



Never interrupt the earth conductor (protective conductor).
Never use 2 wire power cables.

Materials used in the most important parts

Part	Material	Materialcode
Cutter screw	Titanium	Ti
Displacement disk	Titanium	Ti
Shaft bearing unit	Titanium	Ti
Inscription foil	Polyethyleneterephthalate	PET
Cover	Polyoxymethylene	POM
Knob for latch	Polyoxymethylene	POM
Knob for guard door	Polyoxymethylene	POM
Diaphragm seal	Polypropylene	PP
Diaphragm seal holder	Polypropylene	PP
Beaker holder (not complete)	Polypropylene	PP
Beaker clip	Polyoxymethylene	POM
Beaker holder bottom	Polycarbonate	PC
Case	Polyurethane	PUR
Hood	Polyurethane	PUR
Guard door (not complete)	Polymethylmethacrylate	PMMA
Small belt	Polyurethane	PUR
Big belt	Polychloroprene	
Spacer	Polyetherketone	PEEK

Table 5: Materials used for the most important parts

Further materials used:

Metals: Aluminum, nonferrous metals, steel, chromium steel

Electronic parts: Printed circuit boards, motor

Glass parts: Sample beaker made of borosilicate

List of application

Fruit and Vegetables:	approx.	Duration
Apple slices, dried	60 g	4 – 5 s
Apricots, dried (stone removed)	60 g	4 – 5 s
Bananas, dried	80 g	4 x 3 s
Pears, apples	150 g	5 s
Lettuce	150 g	5 s
Figs, dried	80 g	4 x 3 s
Carrots (cooled)	150 g	5 s
Potatoes	120 g	5 s
Kohlrabi	150 g	5 s
Leeks (cooled)	150 g	5 – 7 s
Peaches, dried	80 g	3 s several times
Plums, dried	80 g	4 – 5 s
Rhubarb	100 g	2 x 15 s
Raisins	100 g	3 s several times
Red cabbage	150 g	5 – 7 s
Morello cherries, dried	80 g	3 s several times
Pickled white cabbage	250 g	5 – 7 s
Asparagus	100 g	15 s
Sugarbeet	120 g	5 s
Onions	150 g	5 – 7 s

Meat/Fish/Sausage:	approx.	Duration
Frying sausage, raw	100 g	7 s
Trout (cooled)	120 g	8 – 10 s
Goulash (pork)	100 g	5 – 7 s
Chicken meat (cooled)	100 g	5 – 7 s
Cod (dressed)	120 g	10 s
Raw meat	100 g	10 – 15 s
Raw bacon	80 g	7 s
Salami (Hard-cured sausage)	80 g	5 s
Pig's liver	100 g	5 s
Bacon (boiled)	100 g	7 – 8 s
Gravy-beef	100 g	10 s
Soft-cured sausage/meat loaf	100 g	5 – 7 s

Miscellaneous:	approx.	Duration
Emmentaler (hard cheese)	80 g	12 s
Peanuts, salted	80 g	3 x 3 s
Peanuts with shells	80 g	3 x 3 s
Flakes, granules	80 – 100 g	8 s
Gnocchi (cooled)	100 g	2 x 3 s
Hazelnuts	60 g	3 x 3 s
Cheesecake (cooled)	120 g	5 – 7 s
Croquettes (thawed)	80 g	3 x 3 s
Pizza	80 g	8 – 10 s
Waffles	80 g	4 – 5 s
Waffles with cream filling	80 g	4 s
Soft cheese	80 g	4 – 5 s

Fodder:	approx.	Duration
Hay	20 g	10 s
Straw	20 g	10 s
Dog food (pellets)	70 g	2 x 3 s
Cat food	200 g	8 – 10 s

Table 6: Application data



Where repeat mixing (e.g. 3 x 3 s) is called for, insert the mixer for the time quoted, e.g. 3 s, remove it again and repeat the process as often as stated, loosening the contents in between (by shaking or stirring) if necessary. Samples can first be cooled and then mixed in order to further reduce the build-up of heat.

This list is intended to serve as a guide for mixing your own samples.

You are welcome to contact Büchi at any time for an updated list. If you have any problems or questions concerning the list of applications or samples, please do not hesitate to get in touch with us.

FCC requirements (for USA and Canada)**English:**

This equipment has been tested and found to comply with the limits for a Class A digital device, pursuant to both Part 15 of the FCC Rules and the radio interference regulations of the Canadian Department of Communications. These limits are designed to provide reasonable protection against harmful interference when the equipment is operated in a commercial environment.

This equipment generates, uses and can radiate radio frequency energy and, if not installed and used in accordance with the instruction manual, may cause harmful interference to radio communications. Operation of this equipment in a residential area is likely to cause harmful interference in which case the user will be required to correct the interference at his own expense.

Français:

Cet appareil a été testé et s'est avéré conforme aux limites prévues pour les appareils numériques de classe A et à la partie 15 des réglementations FCC et à la réglementation des radio-interférences du Canadian Department of Communications. Ces limites sont destinées à fournir une protection adéquate contre les interférences néfastes lorsque l'appareil est utilisé dans un environnement commercial.

Cet appareil génère, utilise et peut radier une énergie à fréquence radioélectrique, il est en outre susceptible d'engendrer des interférences avec les communications radio, s'il n'est pas installé et utilisé conformément aux instructions du mode d'emploi. L'utilisation de cet appareil dans les zones résidentielles peut causer des interférences néfastes, auquel cas l'exploitant sera amené à prendre les dispositions utiles pour pallier aux interférences à ses propres frais.

BUCHI Affiliates:

Europe

Switzerland/Austria

BUCHI Labortechnik AG
CH – 9230 Flawil
T +41 71 394 63 63
F +41 71 394 64 64
buchi@buchi.com
www.buchi.com

Italy

BUCHI Italia s.r.l.
IT – 20010 Cornaredo (MI)
T +39 02 824 50 11
F +39 02 575 12 855
italia@buchi.com
www.buchi.com/it-it

Benelux

BUCHI Labortechnik GmbH
Branch Office Benelux
NL – 3342 GT Hendrik-Ido-Ambacht
T +31 78 684 94 29
F +31 78 684 94 30
benelux@buchi.com
www.buchi.com/bx-en

Russia

BUCHI Russia/CIS
Russia 127287 Moscow
T +7 495 36 36 495
russia@buchi.com
www.buchi.com/ru-ru

France

BUCHI Sarl
FR – 94656 Rungis Cedex
T +33 1 56 70 62 50
F +33 1 46 86 00 31
france@buchi.com
www.buchi.com/fr-fr

United Kingdom

BUCHI UK Ltd.
GB – Oldham OL9 9QL
T +44 161 633 1000
F +44 161 633 1007
uk@buchi.com
www.buchi.com/gb-en

Germany

BUCHI Labortechnik GmbH
DE – 45127 Essen
T +800 414 0 414 0 (Toll Free)
T +49 201 747 49 0
F +49 201 747 49 20
deutschland@buchi.com
www.buchi.com/de-de

Germany

BUCHI NIR-Online
DE – 69190 Walldorf
T +49 6227 73 26 60
F +49 6227 73 26 70
nir-online@buchi.com
www.nir-online.de

America

Brazil

BUCHI Brasil Ltda.
BR – Valinhos SP 13271-200
T +55 19 3849 1201
F +55 19 3849 2907
brasil@buchi.com
www.buchi.com/br-pt

USA/Canada

BUCHI Corporation
US – New Castle, DE 19720
T +1 877 692 8244 (Toll Free)
T +1 302 652 3000
F +1 302 652 8777
us-sales@buchi.com
www.buchi.com/us-en

Asia

China

BUCHI China
CN – 200052 Shanghai
T +86 21 6280 3366
F +86 21 5230 8821
china@buchi.com
www.buchi.com/cn-zh

India

BUCHI India Private Ltd.
IN – Mumbai 400 055
T +91 22 667 75400
F +91 22 667 18986
india@buchi.com
www.buchi.com/in-en

Indonesia

PT. BUCHI Indonesia
ID – Tangerang 15321
T +62 21 537 62 16
F +62 21 537 62 17
indonesia@buchi.com
www.buchi.com/id-in

Japan

Nihon BUCHI K.K.
JP – Tokyo 110-0008
T +81 3 3821 4777
F +81 3 3821 4555
nihon@buchi.com
www.buchi.com/jp-ja

Korea

BUCHI Korea Inc.
KR – Seoul 153-782
T +82 2 6718 7500
F +82 2 6718 7599
korea@buchi.com
www.buchi.com/kr-ko

Malaysia

BUCHI Malaysia Sdn. Bhd.
MY – 47301 Petaling Jaya,
Selangor
T +60 3 7832 0310
F +60 3 7832 0309
malaysia@buchi.com
www.buchi.com/my-en

Singapore

BUCHI Singapore Pte. Ltd.
SG – Singapore 609919
T +65 6565 1175
F +65 6566 7047
singapore@buchi.com
www.buchi.com/sg-en

Thailand

BUCHI (Thailand) Ltd.
TH – Bangkok 10600
T +66 2 862 08 51
F +66 2 862 08 54
thailand@buchi.com
www.buchi.com/th-th

BUCHI Support Centers:

South East Asia

BUCHI (Thailand) Ltd.
TH-Bangkok 10600
T +66 2 862 08 51
F +66 2 862 08 54
bacc@buchi.com
www.buchi.com/th-th

Middle East

BUCHI Labortechnik AG
UAE – Dubai
T +971 4 313 2860
F +971 4 313 2861
middleeast@buchi.com
www.buchi.com

Latin America

BUCHI Latinoamérica Ltda.
BR – Valinhos SP 13271-200
T +55 19 3849 1201
F +55 19 3849 2907
latinoamerica@buchi.com
www.buchi.com/es-es

We are represented by more than 100 distribution partners worldwide.
Find your local representative at: www.buchi.com