



# ***LAB Online Exhibition***



**Operation Manual**



**knowledge**



**Action movie**

# Identification

These Operating Instructions apply to the **Büchi B-302** moisture analyzer with touch-screen and graphical display.



Read these instructions thoroughly before you use the **Büchi B-302**. Store these instructions in the immediate vicinity of the apparatus so that they may be consulted at any time.

The unit must only be connected to the mains and switched on after having completed all necessary preparations.

Chapter 2 contains important safety information. Knowledge of this imperative for the safe operation of the moisture analyzer.

Subject of technical change without notice. No part of these instructions may be reproduced in any whatsoever or processed, reproduced or disseminated by means of electronic or optical systems without the express written permission of Büchi Labortechnik AG. All rights reserved.

Copyright © Büchi Labortechnik AG 2003

en Version: 350-8104-014b1

Order Code  
96911

■ *Overview of the instrument*

# Overview of the instrument

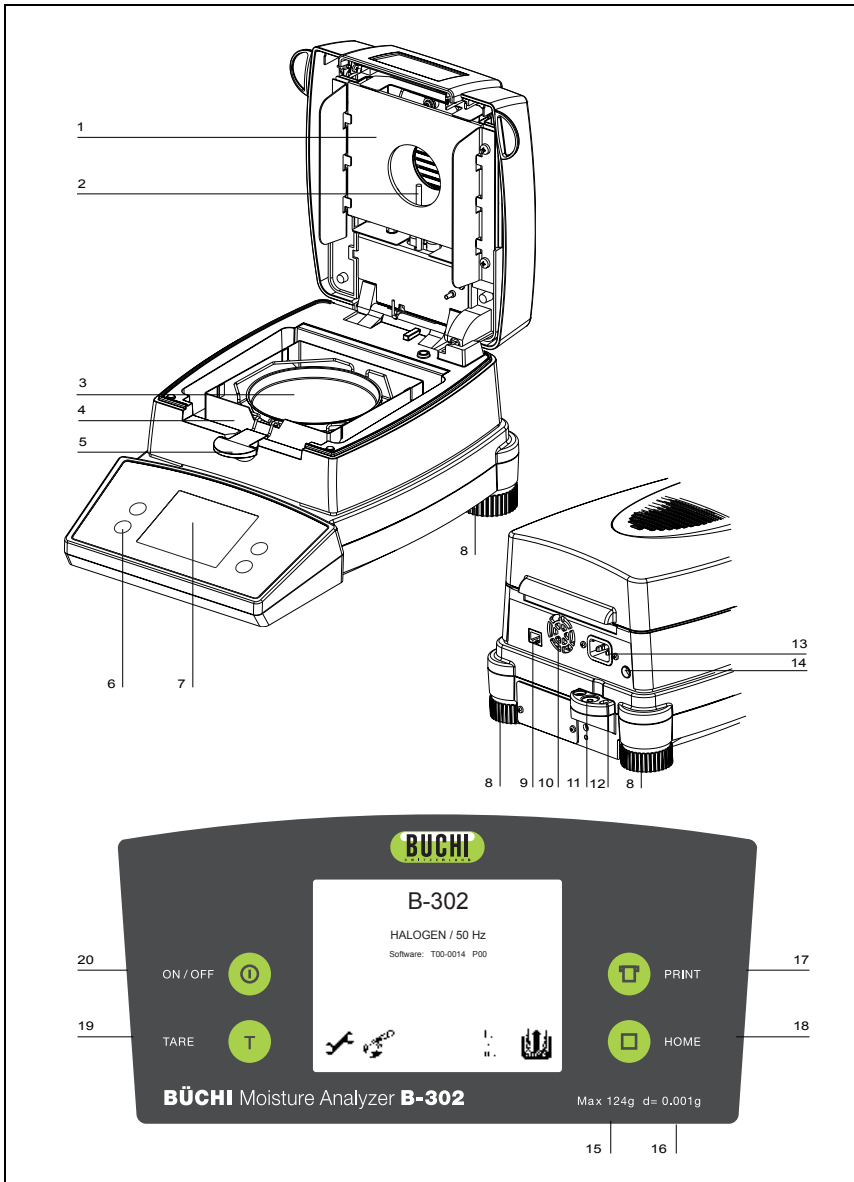

## Overview of the instrument

No.	Description	Section
1	Heater	8.1
2	PT100 temperature sensor	17.2
3	Weighing pan	3.3 / 8.2
4	Draftshield	3.3
5	Sample holder	3.3
6	Keypad	5.1
7	Touch screen	5.2
8	Rotating adjustable feet	3.7
9	Serial interface, RJ45 socket	18.1
10	Fan	3.9
11	Levelling bubble	3.7
12	Mechanical anti-theft protection	
13	Mains connection socket	3.5
14	Mains fuse	19.2
15	Weighing range	20.1
16	Readability	20.1
17	Print key	5.1
18	Home key	5.1
19	Tare key	5.1
20	ON / OFF key	3.9 / 5.1

## ■ *Table of Contents*

	Identification .....	1
	Overview of the instrument .....	2
<b>1</b>	<b>Introduction .....</b>	<b>7</b>
1.1	Operating Instruction tips .....	7
1.2	Warranty .....	8
<b>2</b>	<b>Safety .....</b>	<b>9</b>
2.1	Representations and symbols .....	9
2.2	Safety instructions.....	9
<b>3</b>	<b>Set up .....</b>	<b>11</b>
3.1	Unpacking .....	11
3.2	Transport, storage .....	12
3.2.1	Transport and shipping .....	12
3.2.2	Storage .....	12
3.3	Inspection and assembly.....	13
3.4	Choosing a suitable location.....	14
3.5	Connecting to power.....	15
3.6	Safety measures.....	16
3.7	Leveling .....	16
3.8	Weight calibration.....	17
3.9	First measurement .....	18
<b>4</b>	<b>Methods, Measurements and Batch.....</b>	<b>22</b>
4.1	Methods.....	22
4.2	Measurements and Batch .....	23
<b>5</b>	<b>Operation.....</b>	<b>24</b>
5.1	The keypad.....	24
5.2	The touch screen.....	24
5.3	Numerical Data Entry .....	25
5.4	Activation / Deactivation .....	26
5.5	Text Entry .....	26

<b>6</b>	<b>The Home Screen</b> .....	<b>27</b>
<b>7</b>	<b>The Configuration</b> .....	<b>28</b>
7.1	Loading and Saving the Configuration .....	28
7.2	Setting the Configuration .....	28
7.2.1	Language .....	30
7.2.2	Date and Time .....	30
7.2.3	Contrast.....	31
7.2.4	Buzzer .....	31
7.2.5	Anti-Theft Encoding.....	31
7.2.6	Working mode .....	32
7.2.7	Data protection .....	33
7.2.8	Auto start .....	34
7.2.9	Print format .....	34
7.2.10	Print rate .....	37
7.2.11	RS232 Interface.....	38
<b>8</b>	<b>Determining moisture levels</b> .....	<b>39</b>
8.1	Fundamental principles.....	39
8.1.1	Adapting to the current test procedure.....	40
8.2	Sample preparation.....	40
8.2.1	Preventing samples from skinning over.....	41
<b>9</b>	<b>Drying</b> .....	<b>43</b>
9.1	Setting and Measuring the Starting Weight .....	43
9.2	During the Drying Process .....	45
9.3	After the Drying Process .....	46
<b>10</b>	<b>Setting the method</b> .....	<b>47</b>
10.1	Name.....	47
10.2	Heating .....	48
10.3	Stop mode .....	51
10.4	Unit.....	53
10.5	Target weight .....	54
10.6	Standby temperature .....	55

## ■ *Table of Contents*

<b>11</b>	<b>Units .....</b>	<b>56</b>
<b>12</b>	<b>Measured Data Management .....</b>	<b>58</b>
<b>13</b>	<b>Methods List .....</b>	<b>59</b>
<b>14</b>	<b>Batch List .....</b>	<b>60</b>
<b>15</b>	<b>List of Measured Values .....</b>	<b>62</b>
<b>16</b>	<b>Statistics .....</b>	<b>63</b>
<b>17</b>	<b>Calibration, Adjustment .....</b>	<b>64</b>
17.1	Balance Calibration .....	65
17.2	Temperature adjustment.....	68
<b>18</b>	<b>Data transfer .....</b>	<b>72</b>
18.1	Connections.....	73
18.2	Remote control commands .....	74
18.2.1	Examples of remote control .....	75
<b>19</b>	<b>Service .....</b>	<b>76</b>
19.1	Maintenance and servicing.....	76
19.2	Replacing the power fuse .....	77
19.3	Error messages.....	78
19.3.1	Notes on correcting faults.....	78
19.4	Customer Service .....	79
<b>20</b>	<b>Overview .....</b>	<b>80</b>
20.1	Technical data.....	80
20.2	Accessories .....	83

# 1 Introduction

The B-302 moisture analyzer is easy to operate. It is used as a quick and reliable means of determining the moisture content in powders and liquids by the thermogravimetric principle.

The key features of the B-302 moisture analyzer:

- high-end balance technology built to the highest international standard
- optimum resolution
- simple operation through menu controlled touch-screen
- large viewing window for easy sample monitoring
- a memory for 50 methods, with all the drying settings
- a memory for 999 measurements, which can be organized in different batches
- automatic detection that the measurement has ended by means of ADAPTSTOP
- password protection to prevent unauthorized changes to the instrument configuration and drying parameters
- anti-theft code
- printout in line with GLP guidelines (Good Laboratory Practice)
- software update via the Internet

## 1.1 Operating Instruction tips

Take the time to read these Operating Instructions from start to finish so that you can make full use of the many benefits and features of the B-302 moisture analyzer in your day-to-day work.

These Operating Instructions contain guidance in the form of pictographs and keypad diagrams, which should help you in finding the required information:

- Key names are presented inside quotation marks and are highlighted in bold font: «**ON/OFF**» or «**OK**».
- See chapter 2 "Safety" for the symbols to indicate warnings and tips.

## ■ 1 Introduction

### 1.2 Warranty

A warranty card, which was filled in by your Büchi dealer before you received the moisture analyzer, is enclosed with the Operating Instructions.



#### **NOTE**

Check that the warranty card is inside these Operating Instructions and that it has been duly completed.

## 2 Safety

### 2.1 Representations and symbols

Important safety-related instructions are highlighted visually with a description of what to do:

 <b>DANGER</b>
<b>Warning of a possible danger which may lead to death or to serious injury.</b>

 <b>CAUTION</b>
<b>Warning of a possible danger which may lead to minor injury or damage.</b>

 <b>NOTE</b>
Tips and important rules on how to use the moisture analyzer correctly.

### 2.2 Safety instructions

- When using the instrument in surroundings with increased safety requirements, pay careful attention to the appropriate regulations.
- Only use an extension cord with a protective ground conductor.
- If the power cord is damaged, disconnect the instrument from the electrical supply immediately and replace the power cord.
- If there is any reason to believe that it is no longer possible to operate the moisture analyzer safely, unplug the instrument immediately from the electrical supply and secure it so that it cannot be operated inadvertently.
- When carrying out maintenance work, it is essential to follow the tips in chapter 19.1 "Maintenance and servicing".
- The Operating Instructions should be read by everyone who has to operate the instrument and must be kept handy on-site at all times.



## **DANGER**

Do not place any flammable materials on, under or beside the instrument.

Leave enough clearance around the instrument to prevent a build-up of heat.

The moisture analyzer may not be used to analyze explosive, highly flammable samples.

Do not operate the moisture analyzer in areas where there is any risk of explosion.

Sample materials which release toxic substances must be dried in a fume hood. Take care not to inhale any harmful vapors.

Ensure that no liquid seeps inside the instrument or into the connection ports on the back of the instrument.

If you spill any liquid onto the instrument, unplug it from the electrical supply immediately.

Do not operate the moisture analyzer again until you have had it checked by an Büchi service engineer.



## **CAUTION**

Some of the parts, like the heating element and the viewing window, may become considerably hotter while it is in operation. Only touch the instrument using the handles provided.

Take care when you remove the sample. The actual sample, the heating unit and sample pans used may still be very hot.

The moisture analyzer should generally be used for drying substances containing water. Sample materials which give off aggressive vapors (like acids) may cause corrosion problems to develop on parts of the instrument.

If any damage or injury occurs, liability and responsibility rest with the user.

## 3 Set up

### 3.1 Unpacking

The moisture analyzer comes in environmentally-friendly packaging, specifically developed for this precision instrument, which provides optimum protection for the instrument during transportation.



#### NOTE

Retain the original packaging in order to avoid the moisture analyzer becoming damaged in transit when it is shipped or transported and to store the moisture analyzer under optimum conditions if it is out of operation for an extended period.

Follow instructions carefully when you unpack the moisture analyzer in order to avoid damaging it:

- Unpack the instrument carefully and gently. This is a precision instrument.
- When temperatures outside are very low, the balance should first be stored for a few hours in the unopened transport package in a dry room at normal room temperature, so that no condensation settles on the balance when it is unpacked.
- Check the moisture analyzer for any external visible signs of damage immediately after you unpack it. If you find that it has been damaged in transit, notify your Büchi service agent immediately.
- If the moisture analyzer is not being put into operation immediately after purchase, store it in a dry place with minimal fluctuations in temperature (see chapter 3.2.2 "Storage").
- Read these Operating Instructions carefully before operating the balance, even if you have used Büchi instruments before and pay particular attention to the safety instructions (see chapter 2 "Safety").

## ■ 3 Set up

### 3.2 Transport, storage

#### 3.2.1 Transport and shipping

Your moisture analyzer is a precision instrument. Treat it with care. Avoid shaking it or subjecting it to any heavy jolts or vibrations during transport.

Avoid serious temperature fluctuations and getting the instrument damp during transport.



#### **NOTE**

The moisture analyzer should ideally be shipped and transported in its original packaging to avoid damage in transit.

#### 3.2.2 Storage

If you do not intend to use the instrument for a long time, unplug it from the electrical supply, clean it thoroughly (see chapter 19 "Service") and store it in a place that meets the following conditions:

- No serious shaking or vibrations
- No serious fluctuations in temperature
- No direct exposure to sunlight
- No moisture



#### **NOTE**

The moisture analyzer should ideally be stored in its original packaging because it gives it optimum protection.

### 3.3 Inspection and assembly

The moisture analyzer does not come fully assembled. Once you have unpacked all the parts, check that the delivery is complete and assemble the individual components in the order indicated below.

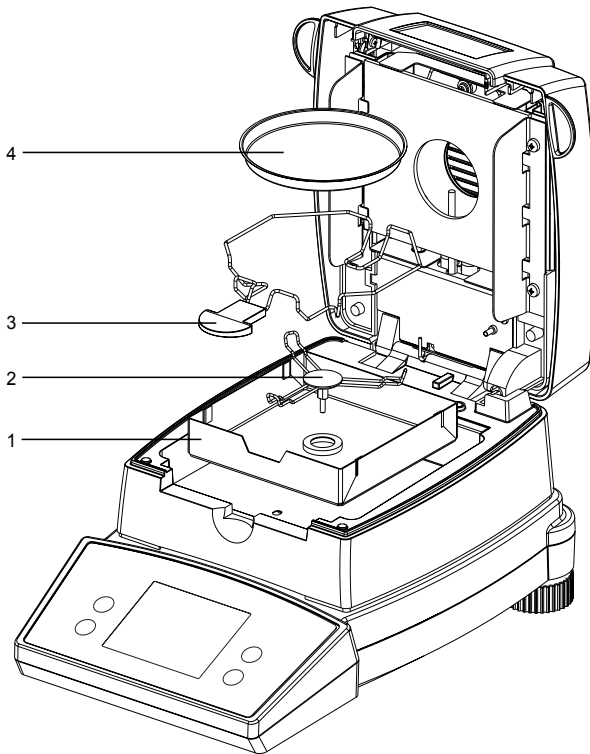

Components delivered	Components delivered
Moisture Analyzer	30 sample pans (4)
Power cord	Operating Instructions
Draftshield (1)	Warranty card
Pan support (2)	Declaration of conformity
Sample holder (3)	

### ■ 3 Set up

- Open the hood and insert the draftshield (1), making sure that it is placed on flat.
- Insert the pan support (2) and turn it so that it locks securely in place.
- Insert the sample holder (3) as shown.



#### **NOTE**

All the parts must be attached together without exerting undue force. Do not apply any force. If you have any problems, contact Büchi customer service.

## **3.4 Choosing a suitable location**

In order to ensure that the moisture analyzer functions properly, select a location that fulfils the following criteria:

- Permissible ambient temperatures
  - Temperature: 5 °C ... 40 °C
  - Relative humidity: 25 % ... 85 %, non-condensing
- Put the instrument on a rigid, firm horizontal base, preferably vibration free
- Make sure that the instrument cannot be shaken or knocked over
- Do not expose it to direct sunlight
- Avoid drafts and excessive temperature fluctuations
- Leave enough clearance around the instrument to prevent a build-up of heat

Do not expose the instrument to high levels of moisture for long periods of time. Avoid letting condensation form on the instrument. If instruments are cold, let them warm up to room temperature (approx. 20 °C) before connecting them to the power source.

Condensation is practically dangerous on instruments which are connected to the power source.

## 3.5 Connecting to power

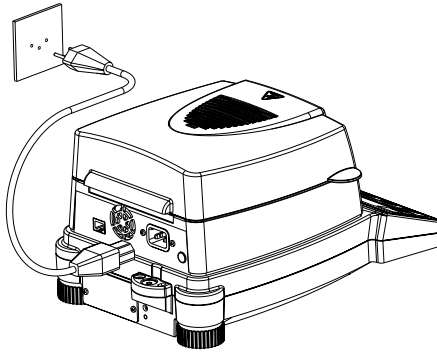

Follow safety instructions when connecting the instrument to the power source:



### **DANGER**

**The instrument may only be operated using the original power cord supplied.**

**If the power cord supplied is not long enough, only use an extension cord fitted with a protective earth conductor.**

**Plug the power cord into a socket which has been installed in accordance with regulations and is fitted with a PE terminal.**

For technical reasons, the heating unit is designed in the factory to accommodate a voltage of 230 V or 115 V and in accordance with your order. Check that the setting match your local setting.

## ■ 3 Set up

### 3.6 Safety measures

The moisture analyzer may only be plugged into a grounded wall outlet. The safety effect may not be undone by using an extension lead without a ground wire. If the voltage is from a power source without a protective earth terminal, arrange for an electrician to create a comparable level of protection in accordance with local installation regulations.

### 3.7 Leveling

In order to function properly, the moisture analyzer must be precisely horizontal.

The instrument is fitted with a “leveling bubble” and two rotatable feet for level-control, with the aid of which it is possible to compensate for small height differences and/or unevennesses in the surface on which the instrument is standing.

The two screw feet must be adjusted so that the bubble is precisely in the center of the sight glass of the leveling bubble.

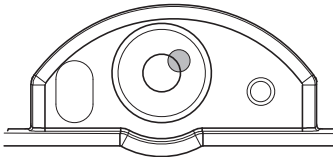

**Incorrect**

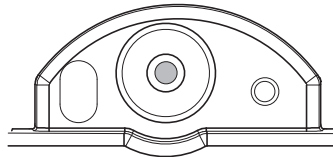

**Correct**



#### **NOTE**

The instrument must be carefully leveled each time it is moved in order to obtain accurate measurements.

### 3.8 Weight calibration

Since the Earth's gravity is not the same everywhere, each balance must be adjusted to compensate for the gravity at each location, in accordance with the underlying physical weighing principle. This adjustment process, which is known as “calibration”, must be carried out on initial installation and then each time the instrument is moved to another location. However, in order to get exact measurements, the instrument should also be recalibrated periodically.



#### NOTE

The moisture analyzer must be calibrated when it is initially installed and then each time it is moved to another location.

If you work in accordance with “Good Laboratory Practice GLP”, observe the prescribed intervals between calibrations (adjustments).

With the aid of the “Intelligent Calibration Mode” (ICM), the instrument can determine the size of the calibration weight itself, allowing exact calibration with different size weights (see chapter 17.1 “Balance Calibration”).

## ■ 3 Set up

### 3.9 First measurement

Once the moisture analyzer is successfully up and running, you can perform an initial measurement to familiarize yourself with the new instrument and to test it for any malfunctions.

Switch the instrument on using the «**ON/OFF**» key. The instrument performs a self-diagnostics test to check the main functions. After completion of the start-up process (which takes about ten seconds), “Zero” appears in the display; this means that the instrument is now ready for operation.

During the first measurement, the instrument uses the drying parameters set at the factory.

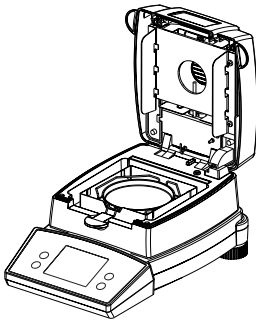

- Open the hood of the instrument
  - Place the sample holder with an empty weighing pan onto the weighing pan holder.
- Note: The weighing pan must sit flat on the weighing pan holder. Always work with the sample holder; it allows you to work safely and prevents possible burning ones self.

- Press the «**TARE**» key.



The instrument is ready to weigh the sample.

### 3 Set up ■

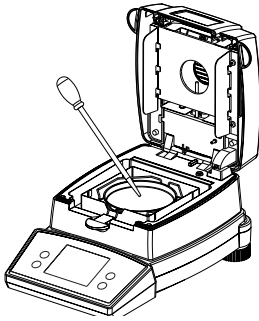

- Pour approx. 1.0 g of water into the weighing pan.

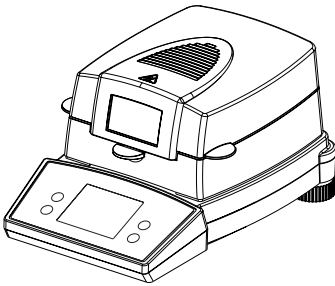

- Close the hood

The instrument is prepared for the first measurement.



- Start the measurement by pressing the «**START**» key.

The heating element heats up the chamber to 105°C, and the fan starts to cool.

### ■ 3 Set up

The dryer display is divided into:

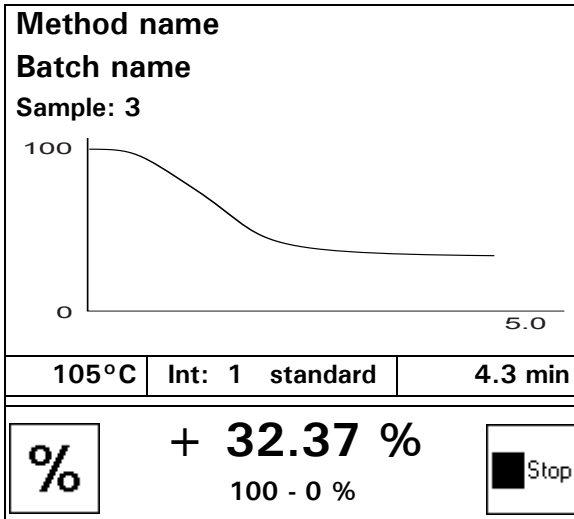

Information about the current method, batch and sample

Change the display by clicking on the graphic or the result (32.37%)

Status line

Measurement display

- The result appears in the measurement and the graphic display (+ 32.37 %) in the unit of measurement set (100 - 0 %).
- The status line displays the current temperature (105°C), the current interval (Int: 1), the heating mode used (standard), and the current duration of the measurement (4.3 min).  
If the temperature is under 40°C, three dashes are displayed „--- °C“.
- Once the drying has ended, an audio signal sounds, and the heating is switched off. The fan keeps running until the temperature in the sample chamber drops below 40°C.

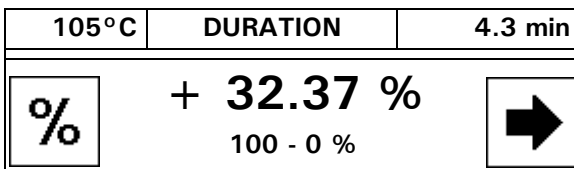

- The result appears in the measurement and graphic display in the unit of measurement set.

- The status line shows how long the measurements takes.

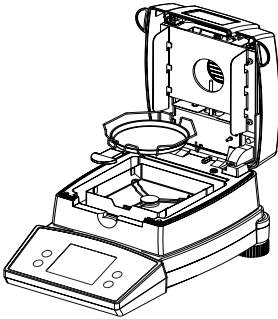

- Setting the unit for the display.
- Forward to measure the starting weight of a new sample.
- Open the hood
- Carefully remove the weighing pan, only gripping the sample holder by the handle.

Caution! All the parts of the sample chamber are hot.

Allow the weighing pan and holder to cool down before doing anything else with them.

- Insert a new weighing pan into the instrument.
- Press the «TARE» Key; the instrument is ready for you to perform a new measurement.



## CAUTION

The weighing pan and holder are hot!

## **4 Methods, Measurements and Batch**

The moisture analyzer supports the saving of fifty different methods. Each method comprises the settings for the drying program and the starting weight.

A number of measurements are normally performed with the same sample in order to obtain conclusive results. These multiple measurements are combined in a batch. The moisture analyzer has memory capacity for 999 measurements. It does not matter how the measurements are divided over the different batches.

### **4.1 Methods**

The following data is saved for each method:

- Method name
- Drying program with:
  - Interval settings (temperature, mode, ...)
  - Stop mode settings (d/s, %/s, ...)
  - Standby temperature
  - Unit for the result
- Starting weight with:
  - Nominal weight
  - Upper weight limit (maximum)
  - Lower weight limit (minimum)

If the method protection is set in the configuration menu under Password Protection, the methods saved are protected against changes or only the methods already saved can be used (chapter 7.2.7 "Data protection").

All the methods saved are displayed in the methods list. The settings for the individual methods can also be printed out there (chapter 13 "Methods List").

## 4.2 Measurements and Batch

The following data is saved for each measurement:

- Method used for drying
- Drying data with:
  - Starting weight
  - End weight
  - Duration of the measurement
  - Date and time
  - Number of the measurement within the series of measurements (sample counter)
- Batch to which the measurement belongs





If the measured value protection is set in the configuration menu under Password Protection, the measurements saved are protected against changes or clearing a measured value (chapter 7.2.7 "Data protection").

All the measurements saved are displayed in the batch list and the measured values list. The batch and the individual measured values can also be printed out there (chapter 14 "Batch List" and chapter 15 "List of Measured Values").





## ■ 5 Operation

# 5 Operation

## 5.1 The keypad

Key	Designation	Function
	«ON/OFF»	<ul style="list-style-type: none"><li>• To switch the moisture analyzer on and off</li></ul>
	«TARE»	<ul style="list-style-type: none"><li>• To tare the moisture analyzer and to reset to the weight display.</li></ul>
	«PRINT»	<ul style="list-style-type: none"><li>• To start the printout (context-related)</li></ul>
	«HOME»	<ul style="list-style-type: none"><li>• To go back to the Home screen</li></ul>

## 5.2 The touch screen

Key	Designation	Function
 1/2 	«Page selection»	<ul style="list-style-type: none"><li>• To scroll through the pages of the menu (e.g. page 1 of 2)</li></ul>
	«Back space»	<ul style="list-style-type: none"><li>• Deletes the character to the left of the cursor (" ")</li></ul>
	«Cancel»	<ul style="list-style-type: none"><li>• To cancel an input without changing the data</li><li>• To deactivate a setting</li></ul>

Key	Designation	Function
	«OK»	<ul style="list-style-type: none"> <li>• To end an entry sequence and save the data</li> <li>• To activate a setting</li> </ul>

### 5.3 Numerical Data Entry

0.1 ..		10.0	.. 99.9	
7	8	9		
4	5	6		
1	2	3		
0		.		

The number entered, "10.0|" appears in the framed entry box. To the left and right of it are the minimum value, "0.1.." and the maximum value, "..99.9".

Some settings require two numbers to be entered. To facilitate this, the entry line is divided into two areas with the "/" character. If you click on the box required, the cursor "|" is placed into the box to enable you to enter the value.

<b>1..</b>	<b>2 </b>	<b>..99 / 1..</b>	<b>130</b>	<b>..180</b>
<i>Minimum 1</i>	<i>Entry 1 with Cursor</i>	<i>Max. 1 / Min. 2</i>	<i>Entry 2</i>	<i>Maximum 2</i>

## ■ 5 Operation

### Note on activation / deactivation:





Once you click on «OK» at the end of an entry, the setting is activated automatically. However, if you click on «Cancel» to abort the entry, the setting is deactivated.

## 5.4 Activation / Deactivation

Some moisture analyzer settings are only used if they are activated. If these settings are deactivated, they are crossed out.

Click on the relevant key to change the activation status. Depending on the type of setting, the status is changed directly or is not activated until you click on «OK» to exit the current entry, or is deactivated by clicking on «Cancel».

## 5.5 Text Entry

01-Method Pet Food							
A	B	C	D	E	F	G	
H	I	J	K	L	M	N	
O	P	Q	R	S	T	U	
V	W	X	Y	Z			



Change the keypad to lower case letters (a .. z) or to numbers with a variety of special characters (0..9, +, -, \*, /, \, ?, ...).

## 6 The Home Screen

The Home screen provides access to the various functions of the moisture analyzer.

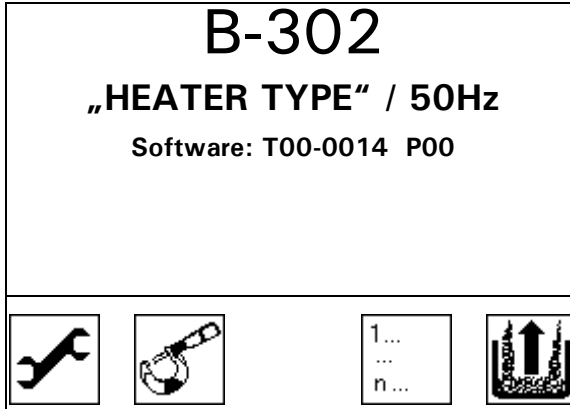

Instrument-specific parameters and the format of the drying report are defined in **Configuration**. You can either work with the basic configuration programmed at the factory or define and save a user configuration which is adapted to suit your specific needs.



**Control and Calibration** contains a variety of functions for the control and calibration of the moisture analyzer.



**Measured Data Management** is used to analyze and manage existing data measurements using statistics, overviews, etc.



Click on the **Drying** key to go to the screen for measuring the starting weight of a new sample which is to be dried.

# 7 The Configuration

## 7.1 Loading and Saving the Configuration

You can reset the moisture analyzer to the basic configuration programmed in the factory at any time or define and save a user configuration which is adapted to suit your specific needs.

- Press «**ON/OFF**» to switch the instrument on.
- During the start-up process, keep the «**TARE**» and «**HOME**» keys pressed in until the function you require appears in the display, then let the keys go:

"FACTORY-CONFIG.": Load the factory configuration.

"USER-CONFIG.": Load the user configuration.

"SAVE CONFIG.": Save the current configuration as the user configuration.

## 7.2 Setting the Configuration

- Press «**HOME**» to go to the Home screen.



- On the Home screen, press the Configuration key.





## ■ 7 The Configuration

### 7.2.1 Language



Setting the language.

Language	
Language:	<input type="text" value="English"/>
<input type="button" value="X"/> Cancel	<input type="button" value="✓"/> OK

In order to change the language, click on the language setting field ("English") and a choice of languages appears. Mark the correct language and click on «OK».

### 7.2.2 Date and Time



Setting the timer.

Date - Time	
Date:	<input type="text" value="22"/> . <input type="text" value="06"/> . <input type="text" value="03"/> dd.mm.yy
Time:	<input type="text" value="10"/> : <input type="text" value="05"/> : <input type="text" value="23"/> hh:mm:ss
Format:	<input type="text" value="dd.mm.yy"/>
<input type="button" value="✓"/> OK	

**NOTE**

If a power failure occurs, the clock keeps running. If this doesn't happen, this indicates that the device's backup battery has run out and must be replaced by Büchi customer service.

**7.2.3 Contrast**



Setting the display contrast.

**7.2.4 Buzzer**

Setting the buzzer and the key tone.

**7.2.5 Anti-Theft Encoding**

The device can be protected against theft by using a freely selectable, four-digit numerical code.

<b>Theft protection</b>	
<b>Code:</b>	8 9 3 7
<b>Protection:</b>	off
 Cancel	 OK

- **Code:**

Enter a new code.

## ■ 7 The Configuration

How the anti-theft function works:

- If the anti-theft code is deactivated, the device can be switched on again and operated after a power failure without having to enter a code.
- If the anti-theft code is activated, the device asks for the code to be input after each power failure.
- If the code is entered incorrectly, the device is blocked.
- If the device is blocked, it must first be disconnected from the power supply, then reconnected and unblocked by entering the correct code.
- After seven consecutive incorrect entries, the display reads "B-302 blocked, Call service". In this case only a Büchi service engineer can unblock the device again.



### NOTE

**The anti-theft encoding is deactivated at the factory.**

The **preprogrammed code** set in the factory is: **8 9 3 7**

This code is the same in all instruments. Therefore, for security reasons enter your own code.

Keep your **own code** in a safe place.

### 7.2.6 Working mode

**MODE**

Setting the working mode.

The working mode indicates how the moisture analyzer is to be used.

**Working mode**

Mode:

---

  
Cancel

  
OK

How the working mode works:

Mode	How it works
Method	The individual measurements are always saved in the same measurement series. If the current method setting is changed, the old series of measurements is deleted.
Batch	The individual measurements are saved as measurement series in different batches. If the current method or batch settings are changed, the old series of measurements is consequently retained.

### 7.2.7 Data protection



The configuration, calibration, methods, drying settings and measured values can be protected against inadvertent or unauthorized changes by entering a user-definable four-digit numerical code.

**Data protection**

**Password:**

**Configuration:**

**Calibration:**

**Methods:**

**Drying:**

**Samples:**





- **Password**

Enter a new password.

## ■ 7 The Configuration

How the data protection function works:

Range	How it works
Configuration	The configuration settings are blocked
Calibration	The balance calibration and the temperature calibration are blocked
Methods	Drying can only take place using the methods currently saved in the memory.
Drying	Drying can only take place using the current method setting.
Samples	No saved measured values and no saved batch can be deleted.



### NOTE

**The data protection is deactivated in the factory settings.**

The **preprogrammed password** set in the factory is: **7 9 1 4**

This password is the same for all instruments and is always valid, at the same time as a password selected by the operator.

Keep a record of your **own password**.

### 7.2.8 Auto start



Switching on the auto start

If auto start is switched on (not crossed out), the measurement is started as soon as the sample chamber is closed. This is provided that the moisture analyzer is prepared for a new measurement.

### 7.2.9 Print format



The drying report can be configured.

The options marked are contained in the report and are printed (see example).

When a peripheral instrument (e.g. a printer) is connected, the instrument interface must be configured (see chapter 7.2.11 "RS232 Interface").

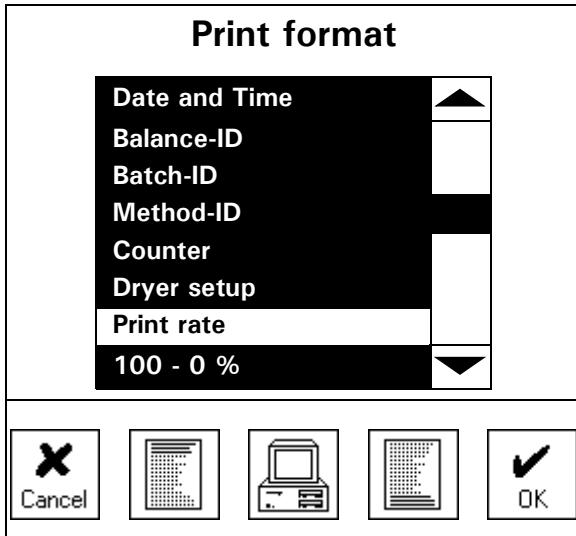

- **Protocol header**



Entry of header.

- **MODE PC**



The "MODE PC" function allows the measurement printout to be output in a format which the PC can support. This format only affects the print rate printout and is used for the graphical evaluation of the drying process with the aid of a computer program (such as Excel). The individual measurements are output separated by tabs, allowing them to be imported easily into a table.

- **Protocol footer**



Entry of footer and defining the control sequence for the end of the protocol.

## ■ 7 The Configuration

Example of a report printout with all the available selection options:

Instrument : B-302	<i>The predefined headline 1</i>
-----	<i>The predefined headline 2</i>
Street	<i>e.g. new headline 3</i>
P.O. Box	<i>e.g. new headline 4</i>
Zip code	<i>e.g. new headline 5</i>
(Blank line)	<i>Blank line at the end of the protocol header</i>
Date 07.10.2002 Time 11:06:01	<i>Date and time, if this is selected</i>
Name : B-302 Hardware identi. : 3600-1	<i>Balance ID, if this is selected</i>
Batch : Can dog H&B	<i>Batch ID, if this is selected</i>
Method : Pet food	<i>Method ID, if this is selected</i>
Sample : 1	<i>Measurement series counter, if this is selected</i>
Interval : 1 Temperature : 105 C Mode : boost  Stop mode: Auto stop : 2/20 d/s  Standby Temp. : 40 C	<i>Dryer setup, if this is selected</i>
Original weight : + 2.186 g	<i>Starting weight is always printed</i>
Mode Temp Time 100 - 0 % ----- B 105 C 1.0 min + 86.81 % B 140 C 2.0 min + 68.08 % B 140 C 3.0 min + 51.97 % 102 C 4.0 min + 44.05 % 98 C 5.0 min + 37.70 % 100 C 6.0 min + 29.84 % 100 C 7.0 min + 24.38 % 100 C 8.0 min + 22.64 % END 100 C 8.2 min + 22.60 %	<i>The measurement is printed in the unit set for drying, provided the print rate function is selected.  The individual values are separated by tabs in the "MODE PC".</i>
100 - 0 % : + 22.60 %  Stop : Auto stop d/s	<i>Drying results are always printed</i>
0 - 100 % : + 73.40 %	<i>Result 0 - 100 % (Each calculation can be set separately too)</i>
Final weight : + 0.494 g	<i>Final weight is always printed</i>
Duration : 8.2 min	<i>Duration is always printed</i>
Operator:	<i>Operator ID, if this is selected</i>
Signature :	<i>Signature, if this is selected</i>

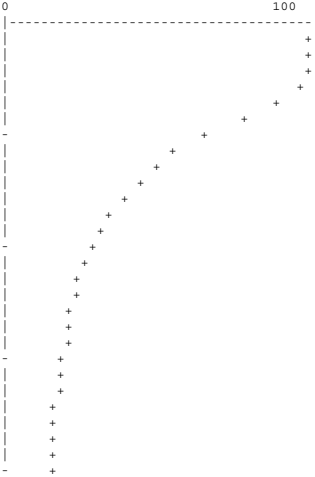
Last calibr. weight: 22.06.02	<i>Balance calibration information, if this is selected</i>
Last adjust. temp. : 22.06.02	<i>Temperature adjustment information, if this is selected</i>
<p style="text-align: center;">100 - 0 %</p>  <p style="text-align: center;">8.2 min</p>	<i>Graphic printout, if this is selected</i>
*****	<i>The predefined footline 5</i>
(Line feed)	<i>Line feed at the end of the protocol footer</i>
(e.g. automatic Form feed)	<i>The controlsequence at the end of the protocol (sequence can be defined in the last footline)</i>

### 7.2.10 Print rate



Setting the print rate.

The interval at which interim results are printed is set with the print rate.

## ■ 7 The Configuration

### 7.2.11 RS232 Interface

**RS  
232**

The RS232/V24 interface on the moisture analyzer is matched to the interface of a peripheral device with the aid of the interface functions (see chapter 18 "Data transfer").

<b>Interface RS232</b>	
<b>Baudrate:</b>	<input type="text" value="9600"/>
<b>Parity:</b>	<input type="text" value="7-even-1stop"/>
<b>Handshake:</b>	<input type="text" value="Hardware"/>
<input type="button" value="X&lt;br/&gt;Cancel"/>	<input type="button" value="✓&lt;br/&gt;OK"/>

In order to change the settings, click on the relevant field ("9600", "7-even-1stop" or "Hardware") and a selection of setting appears. Mark the correct setting and click on «**OK**».

## 8 Determining moisture levels

The moisture analyzer is used as a quick and reliable means of determining the moisture content in powders and liquids by the thermogravimetric process.

### 8.1 Fundamental principles

The term moisture does not just relate to water, it also encompasses all substances which evaporate when they are heated. Alongside water, they also include

- fats
- oils
- alcohol
- solvents
- etc...

There are different techniques for determining the moisture of a material.

Thermogravimetry is the technique used in the moisture analyzer. In this technique, the sample is weighed before and after heating so as to determine the moisture content from the difference.

The conventional drying oven technique works on the same principle except that, the measurement takes much longer. In the drying oven technique, the sample is heated from the outside inwards by a stream of hot air so as to draw out the moisture.

In the case of the IR-radiation used in the moisture analyzer, the radiation mainly penetrates into the sample where it is converted into heat energy, heating the sample from the inside out. A small portion of the IR-radiation is reflected by the sample; this reflection is lower in dark samples than in light samples. The penetration depth of the IR-radiation depends on the permeability of the sample. In the case of low-permeability samples, the IR-radiation only penetrates into the upper layers of the sample, which may lead to incomplete drying, charring or combustion. Consequently, the sample preparation is extremely important.

## ■ 8 *Determining moisture levels*

### 8.1.1 **Adapting to the current test procedure**

The moisture analyzer is frequently used in place of other drying techniques (like the drying oven) because it is easier to operate and offers shorter measuring times. Consequently, the conventional measuring process has to be adapted to the moisture analyzer so that comparable results can be achieved.

- Performing a parallel measurement  
Lower temperature setting in the moisture analyzer than in the drying oven technique
- The result achieved with the moisture analyzer does not match the reference
  - Repeat the measurement with a changed temperature setting
  - Vary the end point conditions
- Adapting with the calibration curve or factor

## 8.2 **Sample preparation**

Prepare one sample at a time for measurement. This prevents the sample exchanging moisture with the ambient surroundings. If a number of samples have to be taken simultaneously, they should be packed in air-tight containers so as to ensure that they do not change while they are in storage.

Distribute the sample **evenly** and **thinly** on the weighing pan in order to achieve reproducible results.

If it is applied unevenly, this causes an inhomogeneous distribution of heat in the sample being dried, resulting in incomplete drying or an extension to the measuring time. If the sample is piled up, it heats up with greater intensity in the upper layers, causing combustion or skinning over. The high layer thickness or possible formation of a crust prevents the moisture from escaping from the sample. This residual moisture means that measurement results achieved this way are not verifiable and reproducible.

**Solids:**



- Distribute powder samples evenly on the weighing pan.
- Make coarse samples smaller using a mortar or grinder. Do not expose the sample to any heat while you are grinding it as this will lead to a loss of moisture.

**Liquids:**

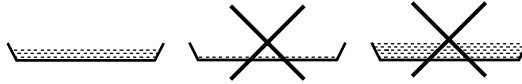

- You are advised to use a sample pad for liquids, pastes or slurry samples. The sample pad offers the following advantages:
  - even distribution on account of the capillary effect
  - no formation of drops
  - quick evaporation due to the larger surface

### 8.2.1 Preventing samples from skinning over

In order to avoid the sample becoming encrusted, solvent can also be added to the sample after the measurement has started. The solvent added has no bearing on the final result of the measurement.

- Start the measurement, automatically or by pressing the «**START**» key.
- The dryer hood can be opened again within 5 seconds of the start. During this time, the words "start drying" are displayed in the info line of the display.
- After opening the sample chamber "close cover" appears in the status line, Now you can add additional solvent at any time until the hood is closed. Once the dryer hood is closed, the measurement is continued. If you press the «**STOP**» key, the measurement is interrupted.

## ■ 8 *Determining moisture levels*



### **NOTE**

The additional solvent is taken into account in the measurement printout because all the interim values are calculated on the basis of the current weight value.

However, it has no bearing on the drying result because the solvent has completely dried off.

## 9 Drying

- Press «HOME» to go to the Home screen.



- On the Home screen, press the Drying key.



### 9.1 Setting and Measuring the Starting Weight

Display when measuring the starting weight

<b>Batch name</b>	
<b>Method name</b>	
Sample: 3	
<b>0.000 g</b>	
0%	100%
... °C	
	1... ... n...
	Start

- **Batch name**

Name of the current batch. The batch name is not displayed in the working mode „Method“.

- **Method name**

Name of the current method.

- **Sample: 3**

The sample counter indicates that the third measurement is being started.

## ■ 9 Drying

### • Last measurement



Go back to the result of the last measurement.  
This key is only visible if a sample has already been dried.

### • Load / Open



Load methods or batches which are already saved in the memory or open a new method or a new batch for drying samples.

Depending on the working mode (see chapter 7.2.6 "Working mode"), this takes you to the appropriate list.

Working Mode	List / Menu
Method	Methods list: chapter 13 "Methods List"
Batch	Batch list: chapter 14 "Batch List"

After loading settings, the sample counter is set accordingly. In other words, a series of measurements is extended or (re-)started.

If the drying is protected, you are asked to enter the password (see chapter 7.2.7 "Data protection").

### • Setting the method



Setting the method for drying the sample (see chapter 10 "Setting the method").

After changing settings, the sample counter is reset to 0, and thus a new series of measurements is opened.

If the drying is protected, you are asked to enter the password (see chapter 7.2.7 "Data protection").

### • Analyze



Analyze and manage existing data measurements using statistics, overviews, etc. (see chapter 12 "Measured Data Management").

- **Start**



Starting drying.

## 9.2 During the Drying Process

Example of how the display looks during drying:

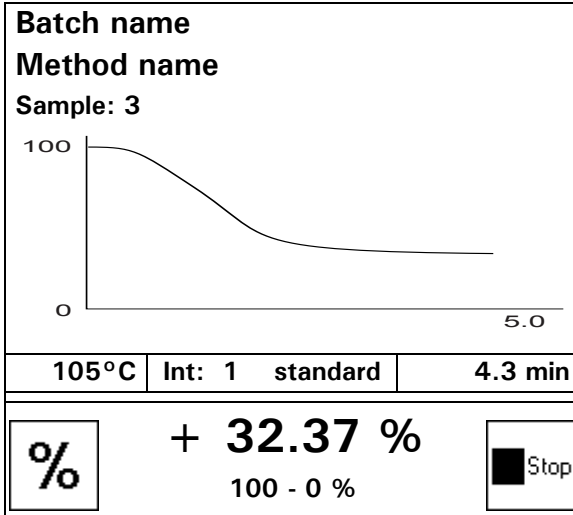

Change the display by clicking on the graphic or the result (32.37 %).

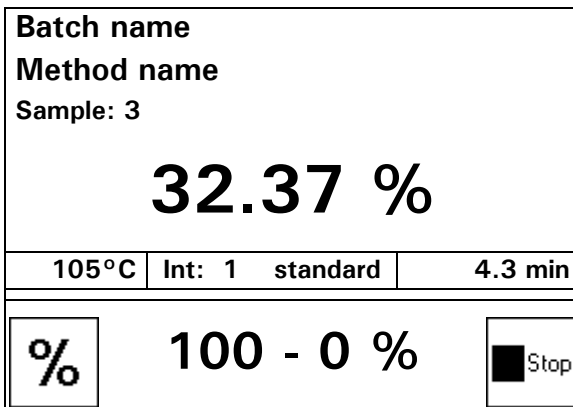

## ■ 9 Drying

- **Unit**



Setting the unit for the display.

The unit of measurement for the printout cannot be changed during the measurement. The units are described in detail in chapter 11 "Units".

- **Stop**



Stopping drying.

### 9.3 After the Drying Process

Example of how the display looks after drying:

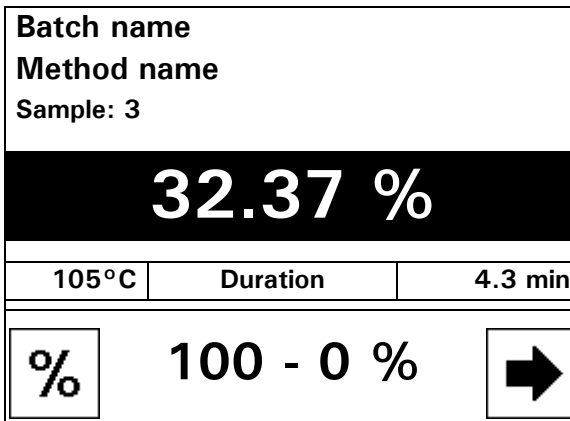

Change the display by clicking on the result (32.37 %) or the graphic.

- **Unit**



Setting the unit for the display.

- **Next measurement**



Forward to measure the starting weight of a new sample.

If the moisture analyzer is tared, it also switches to starting weight mode.

## 10 Setting the method

All the drying parameters are set in this menu.

After changing settings, the sample counter is reset to 0, and thus a new series of measurements is opened.

If the methods or the drying are protected (see chapter 7.2.7 "Data protection"), these settings can only be changed if the correct password is entered first.

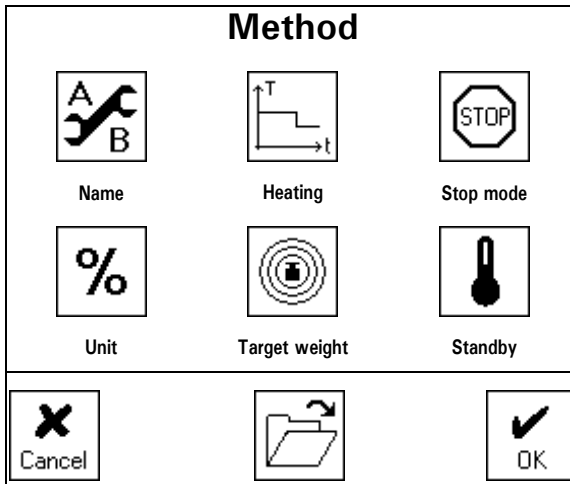

- **Load**



Loading a saved method with the aid of the method list (see chapter 13 "Methods List").

### 10.1 Name



Enter the name of the method.  
The method is saved under this name.

## ■ 10 Setting the method

### 10.2 Heating



Enter the parameters for heating up the sample.  
It can be heated up via three intervals ("I", "II", and "III").

Heating mode				
Int.	T, °C	Mode	t, min	M, %
I	105	std.	3.0	75.0
II	105	std.	5.0	50.0
III	105	std.	10.0	25.0

  
Cancel

  
OK

- **Int.**

Click on intervals "II" and "III" to activate or deactivate (cross out) them. Interval "I" is always active.

- **T, °C**

Enter the drying temperature for the relevant interval.

After 10 minutes temperatures higher than 200°C are automatically adjusted down to 200°C over the course of the next 20 minutes.

Under normal circumstances the drying temperature setting must be lower than in the case of drying with the drying oven technique.

- **Mode**

There are three heating programs available:

- Standard drying
- Boost drying
- Soft drying

### Standard drying

The drying temperature is started up with a high energy output and is kept constant following slight overshooting.

This program is used for most samples.

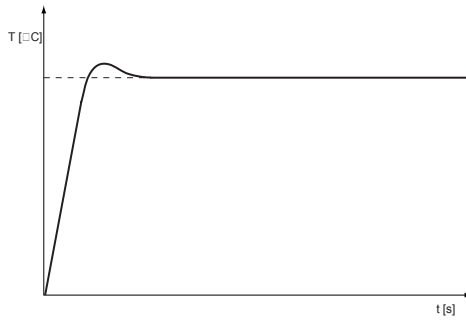

### Boost drying

The temperature is started up with a high energy output and is exceeded by 40% for 3 minutes. Once these 3 minutes have elapsed, the temperature is adjusted down to the drying temperature setting.

This program is used for samples with a very high moisture content.

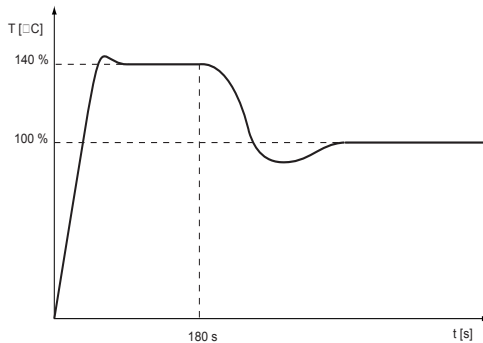

## ■ 10 Setting the method

### Soft drying

The drying temperature is started up gently with a low energy output and is reached after approx. 4 minutes.

This program is used for samples with a low moisture content or if there is a risk of combustion.

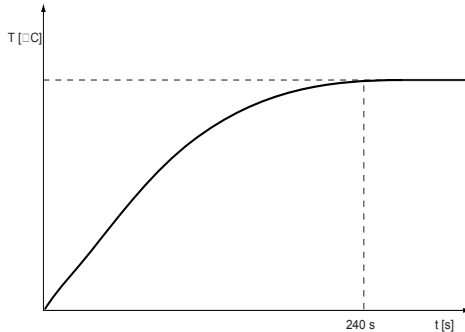

- **t, min**

Enter the maximum duration for the relevant interval.

If this setting is activated (not crossed out), the interval ends at the expiration of this time setting and is switched to the next activated interval.

- **M, %**



Enter the minimum value for the relevant interval.

If this setting is activated (not crossed out), the interval ends if the final weight (100% .. 0%) drops below the set minimum. The moisture analyzer then switches to the next activated interval.

## 10.3 Stop mode



Drying is ended as soon as one of the activated criteria is fulfilled. In order to do this, all the activated settings are tested from the start.

Stop mode		
Auto stop:	2 / 20	d / s
Auto stop:	0.2 / 20	% / s
AdaptStop:	off	
Time:	10.0	min
Minimum:	25.0	%
Delay:	3.0	min
<div style="display: flex; justify-content: space-between;"> <div style="border: 1px solid black; padding: 5px; text-align: center;">  </div> <div style="border: 1px solid black; padding: 5px; text-align: center;">  </div> </div>		

- **Auto stop, d / s**

Enter a end-point condition in digits per second.

If this setting is activated (not crossed out), the drying procedure ends as soon as the reduction in weight, during the time set, is smaller than the number of digits set.

Caution: the reduction in weight must have been greater than the end-point condition at some point.

- **Auto stop, % / s**

Enter a end-point condition in % per second.

If this setting is activated (not crossed out), the drying procedure ends as soon as the reduction in weight, during the time set, is smaller than the % value set. The moist weight (weight value at the start of the measurement) corresponds to a value of 100%.

Caution: the reduction in weight must have been greater than the end-point condition at some point.

## ■ 10 Setting the method

### Explanation of stop mode d / s and % / s

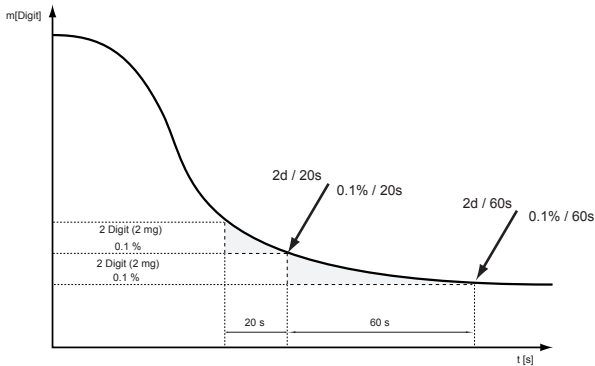

One digit is the smallest change in measurement that can be displayed by the moisture analyzer. 1Digit = 1mg

- **AdaptStop**

Change in a fully automatic end-point condition.

AdaptStop is a fully automatic stop mode which determines the switch-off time on the basis of the drying progress.

- **Time, min**

Enter the maximum duration for the drying process.

If this setting is activated (not crossed out), drying ends after the time set has elapsed.

- **Minimum, %**

Enter a minimum value for ending drying.

If this setting is activated (not crossed out), drying ends if the dry weight (100 % .. 0 %) drops below the set minimum.

- **Delay, min**

Enter a delay for detecting the end of the drying process.

If this setting is activated (not crossed out), the criteria for identifying the end of the drying process are tested, at the earliest, after this delay setting.

In some samples, these settings can be used to prevent drying inadvertently being ended prematurely.

## 10.4 Unit





Set the unit of measurement of the results in the report printout and on the display at the start of a drying process. These settings are also used to print out interim values. The unit of measurement for the printout can only be changed before, not during, a measurement.

This is described in detail in chapter 11 "Units".

**Unit**

<b>100 - 0 %</b>
0 - 100 %
ATRO 100 - 999 %
ATRO 0 - 999 %
g / kg
Residual weight
Weight loss

  
Cancel

  
OK

## ■ 10 Setting the method

### 10.5 Target weight



Setting criteria for the sample weight of a drying process.

The drying process can only be started if the sample weight is within the defined tolerances. If the sample weight is outside the tolerances, the starting weight tolerances are displayed on the screen as an error message.

Target weight	
Nominal:	<input type="text" value="5.000"/> g
Upper limit:	<input type="text" value="6.000"/> g
Lower limit:	<input type="text" value="4.000"/> g
<input type="button" value="X"/> Cancel	<input type="button" value="✓"/> OK

- **Nominal**

Enter the nominal sample weight for drying.

The nominal weight is used to aid in adding the optimum test weight.

- **Upper limit**

Enter the maximum sample weight.

- **Lower limit**

Enter the minimum sample weight.

## 10.6 Standby temperature



Adjusts the temperature in the sample chamber to the set-temperature, provided the sample chamber is closed. The temperature in the status display keeps flashing until the standby temperature is reached.

**Standby temperature**

Temperature:  °C

  
Cancel

  
OK

■ 11 Units

# 11 Units

Units for displaying the measurement results.

### Unit

100 - 0 %

0 - 100 %

ATRO 100 - 999 %

ATRO 0 - 999 %

g / kg

Residual weight

Weight loss

✕  
Cancel

✓  
OK

### Description / Calculation of the units

Explanation of the variables used

- MW: Moist weight (weight value at the start of the measurement)
- DW: Dry weight (weight value at the end of the measurement)

Unit	Calculation
Solids in percent:	$100 - 0\% = \frac{DW}{MW} \cdot 100\%$
Moisture in percent:	$0 - 100\% = -\frac{MW - DW}{MW} \cdot 100\%$
ATRO dry mass:	$ATRO\ 100 - 999\% = \frac{MW}{DW} \cdot 100\%$
ATRO moisture:	$ATRO\ 0 - 999\% = -\frac{MW - DW}{DW} \cdot 100\%$
Residual weight in g / kg [%o]:	$g / kg = \frac{DW}{MW} \cdot 1000$
Residual weight in g:	Residual weight = DW
Moisture in g:	Weight loss = MW - DW

**Explanations for the ATRO units**

The ATRO unit is used for wood and forestry products.

In practice, wood contains different amounts of water, which can change continuously. The water content affects the combustion performance of the wood and the heat value. The water evaporates during drying. When wood is stored in the open air, it reaches the so-called air-dried status (A.D.) of 15% to 20% water content. The moisture is completely removed from the wood by heating the wood to temperatures over 100°C. This condition is called "absolutely dry" (abs. dry).

The wood moisture (*ATRO*) is the amount of water contained in the wood, expressed in terms of the percentage of the mass of the water-free wood and is calculated from the difference between the moist weight (*MW*) and the dry weight (*DW*).

# 12 Measured Data Management





- Press «HOME» to go to the Home screen.



- On the Home screen, press the Measured Data Management key.  
The key is also available when **Drying** (see chapter 9.1 "Setting and Measuring the Starting Weight").

Series	
<b>Batch</b>	: Can dog H&B 23.06. 2
<b>Method</b>	: Pet food
<b>Date</b>	: 23.06.03
<b>Samples</b>	: 3

 Cancel				 OK
---	---	---	---	---

- **Load**



Loads a saved series of measurements with the aid of the batch list (see chapter 14 "Batch List").

- **Inspection**



Inspect the measured values within the selected series of measurements with the aid of the measured values list (see chapter 15 "List of Measured Values").

- **Statistics**



Statistical analysis of the series of measurements (see chapter 16 "Statistics").

## 13 Methods List

The methods list is available when **Drying** (see chapter 9.1 "Setting and Measuring the Starting Weight" and chapter 10 "Setting the method").

The methods saved (in example 3) are available for selection.

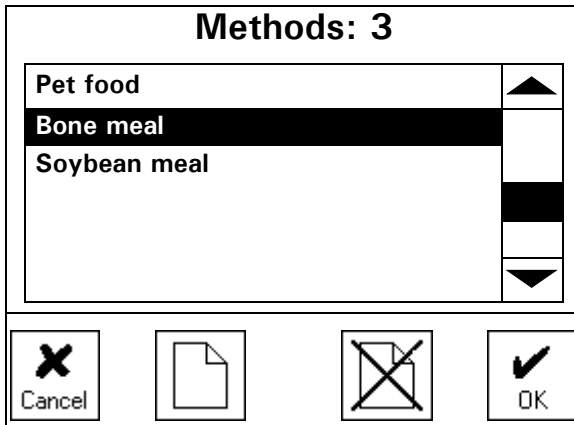

- **New**



Open a new method.

The user is automatically prompted to enter the name.

- **Delete**



Delete the selected method.

If the methods are protected, the correct password must be entered first (see chapter 7.2.7 "Data protection").

# 14 Batch List

The batch list is available when **Drying** (see chapter 9.1 "Setting and Measuring the Starting Weight") and in the **Measured Data Management** (see chapter 12 "Measured Data Management").

The batch saved (in example 49) is available for selection.

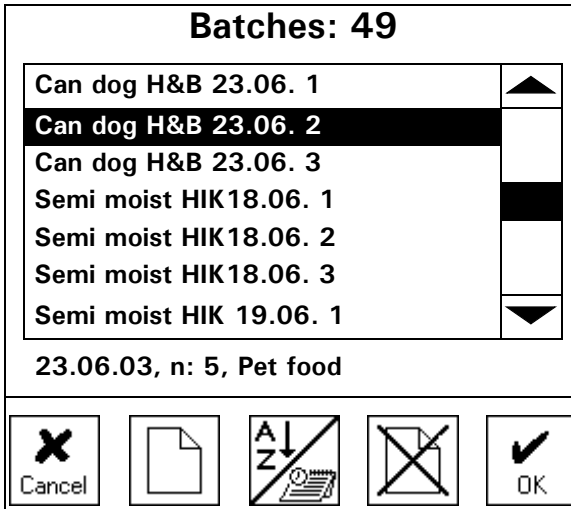

- **New**



Open a new batch (this key is not always available). The user is automatically prompted to enter the name. It then switches to the methods list to enable you to select an existing method or to open a new method.

- **Sorting**



Changes sorting criteria between alphabetical and chronological.

- **Delete**



Delete the selected batch. If the measured values are protected (see chapter 7.2.7 "Data protection"), the correct password must be entered first.

- **23.06.03, n:5, Pet food**

Information about the selected batch:

5 values measured on 23.06.03 using the "Pet food" method.

## ■ 15 List of Measured Values

# 15 List of Measured Values

The list of measured values is available in the **Measured Data Management** (see chapter 12 "Measured Data Management").

The measured values saved within a batch (currently 4) are available for selection in this list.

Samples: 4			
n	Original	100 - 0 %	
4	2.426 g	54.87 %	▲
3	2.425 g	54.85 %	
2	2.423 g	54.80 %	■
1	2.399 g	54.26 %	

23.06.03 - 17:01:03, 10.5 min, Pet food

%              OK

### • Unit



Select the unit of measurement for the measured values (see chapter 11 "Units").

### • Delete



Delete the selected measured value.

If the samples are protected (see chapter 7.2.7 "Data protection"), the correct password must be entered first.

### • 23.06.03 - 17:01:03, 10.5 min, Pet food

Information about the selected measured value:

Values measured on 23.06.03 at 17:01:03 with a duration of 10.5 min using the "Pet food" method.

## 16 Statistics

The statistics is available in the **Measured Data Management** (see chapter 12 "Measured Data Management").

Statistical analysis of the series of measurements or of the batch.

<b>Statistics</b>	
<b>Unit</b>	: 100 - 0 %
<b>Samples</b>	: 5
<b>Mean</b>	: 52.22 %
<b>Maximum</b>	: 52.42 %
<b>Minimum</b>	: 52.02 %
<b>Stddev</b>	: 0.200 %
<b>Stddev %</b>	: 0.383 %

%

1...  
...  
n...

✓  
OK

- **Unit**



Select the unit of measurement for the statistical analysis (see chapter 11 "Units").

- **Measured values**



If this setting is activated (not crossed out), the individual values in the series are also printed out with the statistical data.

## ■ 17 Calibration, Adjustment

# 17 Calibration, Adjustment

- Press «HOME» to go to the Home screen.



- On the Home screen, press the Calibration key.

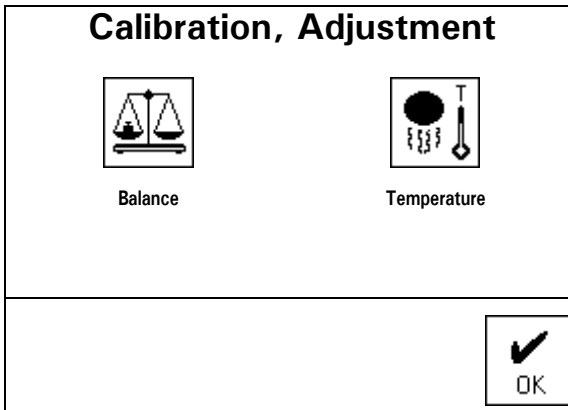

### NOTE

- Recommended interval for the balance calibration, verification:  
1 Month
- Recommended interval for the temperature adjustment, verification:  
1 Year

## 17.1 Balance Calibration



<b>Calibration</b>		
Mode:	<input style="width: 100%;" type="text" value="external"/>	
Def. weight:	<input style="width: 100%;" type="text" value="100.0000"/> g	
<b>0.000 g</b>		
0%	<div style="width: 100%; border: 1px solid black; position: relative;"> <div style="background-color: black; width: 25%; height: 10px; position: absolute; left: 0;"></div> </div>	100%
<b>press start</b>		
<div style="border: 1px solid black; width: 40px; height: 40px; margin: 0 auto; display: flex; align-items: center; justify-content: center;"> <span style="font-size: 2em; margin: 0 5px;">✕</span> </div> <p style="margin: 0; text-align: center;">Cancel</p>	<div style="border: 1px solid black; width: 40px; height: 40px; margin: 0 auto; display: flex; align-items: center; justify-content: center;"> <span style="font-size: 1.5em; margin-right: 5px;">▶</span> </div> <p style="margin: 0; text-align: center;">Start</p>	

- **Mode**

Setting the balance calibration.

- external:
  - External calibration by means of ICM (Intelligent Calibration Mode).
  - Calibration weights in increments of 10g can be used for the moisture analyzer whereby the calibration weights must correspond to the precision of the device.
- ext.-def:
  - External calibration with a freely definable weight.
  - As a criterion for the calibration, a weight with up to ten times the precision of the moisture analyzer can be entered.
- off:
  - No calibration

## ■ 17 Calibration, Adjustment

### • Def. weight

Enter a user-definable weight as a criterion for calibration in "ext.-def." mode (only displayed when mode „ext.-def.“ is set).

### Performing the calibration



Display	Comments		
<table border="1"><tr><td>-- 0000 g</td></tr><tr><td>wait stable</td></tr></table>	-- 0000 g	wait stable	<ul style="list-style-type: none"><li>• The instrument performs a zero point measurement (-- 0000 g is displayed flashing).</li></ul>
-- 0000 g			
wait stable			
<table border="1"><tr><td>0000 g</td></tr><tr><td>measuring</td></tr></table>	0000 g	measuring	<ul style="list-style-type: none"><li>• The instrument performs a zero point measurement (0000 g is displayed flashing).</li></ul>
0000 g			
measuring			
<table border="1"><tr><td>-- 100.000 g</td></tr><tr><td>add weight</td></tr></table>	-- 100.000 g	add weight	<ul style="list-style-type: none"><li>• After the zero point measurement, the display flashes the recommended calibration weight (100.000 g) or the weight defined by you.</li><li>• Place the calibration weight on.</li></ul>
-- 100.000 g			
add weight			
<table border="1"><tr><td>100.000 g</td></tr><tr><td>measuring</td></tr></table>	100.000 g	measuring	<ul style="list-style-type: none"><li>• The display flashes.</li></ul>
100.000 g			
measuring			
<table border="1"><tr><td>+ 99.986 g</td></tr><tr><td>press &lt;SAVE&gt; to adjust</td></tr></table>	+ 99.986 g	press <SAVE> to adjust	<ul style="list-style-type: none"><li>• Once the display stops flashing, this indicates that the calibration has ended.</li><li>• The measured weight is displayed.</li></ul>
+ 99.986 g			
press <SAVE> to adjust			

**After the calibration, verify the measured weight**

The balance shows the measured weight e.g. +99.986 g.



Abort the calibration without saving the measured values.



Save the measured values.  
The balance is now adjusted again.

**Calibration report printout**

Calibration -----
Date 16.10.2002 Time 12:51:36 Name : B-302 Hardware identi. : 3600-1
Reference : + 100.000 g Measured : + 99.986 g
Adjustment OK
Reference : + 100.000 g Measured : + 100.000 g
Operator :

Balance calibration report

Time of the calibration and device data

Values of test



Only printed if the calibration is saved

Values of adjustment

Only printed if the calibration is saved

Operator ID



<b>!</b>	<b>NOTE</b>
The balance calibration can be interrupted at any time by pressing «ON/OFF».	

<b>!</b>	<b>NOTE</b>
If the balance calibration mode is set to „ext.-def“ only the weight correspond to the entered „Def. weight“ may be used.	

## ■ 17 Calibration, Adjustment

### 17.2 Temperature adjustment



Adjustment		
	Set, °C	Act, °C
Temp.-1:	<input type="text" value="100"/>	---
Temp.-2:	<input type="text" value="160"/>	---
--- °C	press start	40.0 min
		

#### • Temp.-1

– Set, °C:

First target temperature. You can enter other target temperatures according to your samples. The default target temperature is 100°C.

– Act, °C:

Temperature which was actually reached.

If the temperature adjustment tool is connected, the temperature is automatically copied over from the temperature adjustment tool. Otherwise, it has to be input manually.

#### • Temp.-2

– Set, °C:

Second target temperature (default 160°C).

– Act, °C:

Temperature which was actually reached.

If the temperature adjustment tool is connected, the temperature is automatically copied over from the temperature adjustment tool. Otherwise, it has to be input manually.

- - - - C press start 40.0 min

Status display with the current temperature of the moisture analyzer and the time required for adjustment.

**Performing the calibration.**

 <b>NOTE</b>
<p>Requires optional temperature adjustment tool (see chapter 20.2 "Accessories").</p> <p>The temperature adjustment tool must be connected to the moisture analyzer via the RS232 interface, and the temperature sensor must be inserted in the sample chamber.</p> <p>More information can be found in the operating instruction of the temperature adjustment tool.</p>





**Display**

---°C    measure temp. 1    40.0 min
--------------------------------------

**Comments**

- The temperature calibration is started and the moisture analyzer heats up to 100°C.
- The status display shows the temperature as well as the time remaining for the temperature adjustment. If there is no temperature adjustment tool connected, the time until it reaches 100°C is displayed (20 min).

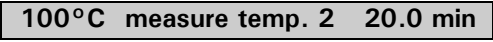
## ■ 17 Calibration, Adjustment

Display	Comments
	<ul style="list-style-type: none"><li>• The instrument copies the temperature value from the temperature adjustment tool; otherwise, the user is prompted to enter the measured temperature manually.</li><li>• It is heated to 160°C (20min).</li><li>• The instrument copies the temperature value from the temperature adjustment tool, or the user is prompted to enter the measured temperature manually.</li></ul>
	<ul style="list-style-type: none"><li>• This indicates that the adjustment has ended.</li></ul>

### After the adjustment, verify the measured temperatures

The balance shows the measured temperatures at the „Act, °C“ values.



Abort the adjustment without saving the measured values.



Save the measured values.  
The temperature measurement is now adjusted again.

Temperature adjustment report printout

Temperature adjustment -----
Date 16.10.2002 Time 12:51:36 Name : B-302 Hardware identi. : 3600-1
Temp. Reference ID : ....
Temperature-1 100 C : 99 C Temperature-2 160 C : 161 C
Adjustment OK
Temperature-1 99 C : 99 C Temperature-2 161 C : 161 C
Operator :

Temperature adjustment report

Time of the temperature adjustment and device data

Identifier of the temperature adjustment tool

Status of the temperature adjustment



Only printed if the adjustment is saved

Temperatures used for adjustment  
Only printed if the adjustment is saved  
Operator ID

	<b>NOTE</b>
<p>The temperature adjustment can be interrupted at any time by pressing «Cancel» or by pressing «ON/OFF».</p>	

■ 18 Data transfer

# 18 Data transfer

The B-302 moisture analyzer is equipped with an RS232/V24 interface for data transfers to peripheral instruments.

Before the data transfer, the RS232 interface must be matched with the one in the peripheral instrument in the instrument's configuration menu (see chapter 7.2.11 "RS232 Interface").

- **Handshake**

Possible handshake: no, Xon/Xoff or Hardware.

- **Baud rate**

Possible baud rates: 300, 600, 1200, 2400, 4800, 9600 or 19200 baud.

- **Parity**

Possible parity: 7-even-1 stop, 7-odd-1 stop, 7-no-2 stop or 8-no-1 stop.

± 12 V	SB	1	2	3	4	5	6	7	8	SP
7-even-1	SB	1.DA	2.DA	3.DA	4.DA	5.DA	6.DA	7.DA	PB	SP
7-odd-1	SB	1.DA	2.DA	3.DA	4.DA	5.DA	6.DA	7.DA	PB	SP
7-no-2	SB	1.DA	2.DA	3.DA	4.DA	5.DA	6.DA	7.DA	1.SP	2.SP
8-no-1	SB	1.DA	2.DA	3.DA	4.DA	5.DA	6.DA	7.DA	8.DA	SP

SB: Start bit                      PB: Parity bit  
 DA: Data bit                      SP: Stop bit

- **Display**

S	D7	D6	D5	D4	D3	D2	D1	D0	U	U	U
---	----	----	----	----	----	----	----	----	---	---	---

Data transfer takes place in ASCII code:

1	2	3	4	5	6	7	8	9	10	11	12	13	14	15	...	...	...
B	B	B	S	D7	D6	D5	D4	D3	D2	D1	DP	D0	B	U	...	CR	LF

B                      Blank (space)  
 S                      Prefix (+, -, space)  
 DP                    Decimal point

D0...D7	Digits
U ...	Unit (only if the weight is stable, otherwise no unit is sent)
CR	Carriage return
LF	Line feed

**NOTE**

Unused positions are filled with spaces.  
The decimal point DP can be between D0 and D7.

**18.1 Connections**

- **Standard duplex connection**

Moisture analyzer	RJ 45	D25 / D9	Peripheral instrument
RS 232 out	2	→ 3 / 2	RS 232 in
RS 232 in	6	← 2 / 3	RS 232 out
GND	5	→ 7 / 5	GND

- **Standard duplex connection with additional hardware handshake in the peripheral instrument**

Moisture analyzer	RJ 45	D25 / D9	Peripheral instrument
RS 232 out	2	→ 3 / 2	RS 232 in
RS 232 in	6	← 2 / 3	RS 232 out
GND	5	→ 7 / 5	GND
CTS	3	← 20 / 4	DTR
DTR	7	→ 5 / 8	CTS

## ■ 18 Data transfer

### • Pin configuration of the RJ45 socket

Moisture analyzer	RJ 45	Remark
n.c.	1	Not connected
RS 232 out	2	Out (V24)
CTS	3	In (V24)
VDC	4	Out (9 ... 16V)
GND	5	0V
RS 232 in	6	In (V24)
DTR	7	Out (V24)
EXTBUS	8	In (5V, logic)

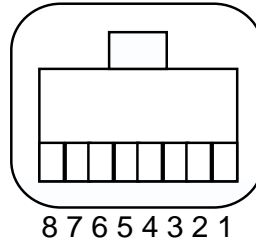

## 18.2 Remote control commands

Command	Function
ACKn	Acknowledge n=0 off; n= 1 on
CAL	Start calibration (only if EXT is selected)
N	Reset instrument
OFF	Switch off instrument
ON	Switch on instrument
PCxxxx	Enter anti-theft code
PDT	Print date and time
PRT	Start printing (Press « <b>PRINT</b> » key)
PST	Start print status
Pn (ttt.t)	Set print mode n = 0 Individually print each value (unstable) n = 1 Individually print a stable value (stable) n = 2 Print after change of load n = 3 Print after each integration period n = 4 Print with time basis in s (ttt.t)
SDTttmmjj hhmmss	Set date and time (German: (Tag, Monat, Jahr, Stunde, Minute, Sekunde)
SDTmmddy hhmmss	Set date and time (Month, Day, Year, Hour, Minutes, Seconds)
T (ttt)	Tare or set tare to a specific value

Command	Function
ZERO	Set instrument to 0 (if weight is stable and within the zero setting range)
Rttt	Adjusts the heating to the required temperature (30 °C ... 230 °C)
ROFF	Switch off heating
PWT (ttt.t)	Print weight value and temperature value Print with time basis in s (ttt.t) (switch off by transmitting PWT)

### 18.2.1 Examples of remote control

 <b>NOTE</b>
Each remote control command must terminate with «CR» «LF». The commands are acknowledged if required.

Command	Description of the function activated
T10	-10.000 g (Tare set to = 10 g)
T1	-1.000 g (Tare set to = 1g)
T	Instrument is tared
R100	Adjusts the temperature to 100 °C

## 19 Service

### 19.1 Maintenance and servicing

The moisture analyzer must be treated carefully and cleaned regularly. This is a precision instrument.



#### **DANGER**

To facilitate maintenance work, the instrument must be disconnected from the power supply. Also ensure that the instrument cannot be reconnected to the power supply during the work by anyone else.

Take care during cleaning that no liquid gets into the instrument. If you spill any liquid onto the instrument, unplug it from the electrical supply immediately. Do not operate the moisture analyzer again until you have had it checked by a Büchi service engineer.

The connection ports on the back of the instrument may not come into contact with liquids.

Regularly dismantle the weighing pan and the weighing pan holder and remove any dirt or dust from under the weighing pan and on the balance housing with a soft brush or a soft, lint-free cloth, moistened with a mild soap solution.

The balance pan and the holder can be cleaned under running water. Take care to ensure that both parts are completely dry before they are re-installed on the balance.



#### **CAUTION**

Never use solvents, acids, alkalis, paint thinners, scouring powders or other aggressive or corrosive chemicals for cleaning since these substances attack the surfaces of the instrument housing and can cause damage.

Regular maintenance of the moisture analyzer by your Büchi service agent will guarantee unrestricted functioning and reliability over many years and will extend the lifespan of the instrument.

## 19.2 Replacing the power fuse

If the display remains dark after you switch on the instrument, this generally means that the instrument's fuse is faulty and has to be changed.

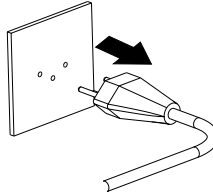

### DANGER

Unplug the instrument from the power source before replacing the fuses.

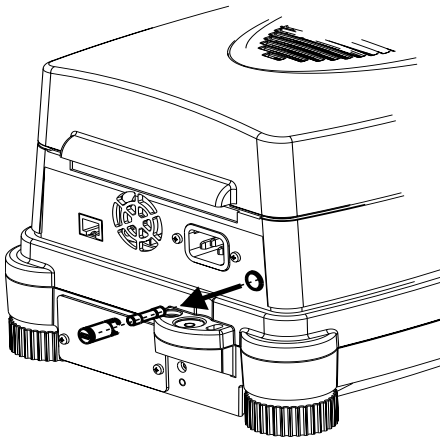

- Screw open the fuse holder on the back of the instrument using a screwdriver, screwing anticlockwise.
- Replace the faulty fuse:
  - 230 volt variant:  
**T 3.15 A, 230 V, 5x20 mm**
  - 115 volt variant:  
**T 6.3 A, 115 V, 5x20 mm**
- If the instrument still does not work after replacing the fuse, contact the Büchi customer service.



### DANGER

Under no circumstances should you use other fuses or attempt to bridge the fuse.

## 19.3 Error messages

The instrument displays an error description in the info line.

 <b>NOTE</b>
If an error occurs without any corresponding description in the info line, a Büchi service engineer must be called.

### 19.3.1 Notes on correcting faults

Faults and their possible causes should be listed in the following table. If you cannot clear the fault on the basis of the table, please contact a Büchi service engineer.

Fault	Possible causes
„Start value too small“	<ul style="list-style-type: none"> <li>• The sample weight is too small (&lt;0.200 g). The sample weight must be greater than 0.200 g.</li> </ul>
Weight display does not light up	<ul style="list-style-type: none"> <li>• Instrument is not switched on</li> <li>• Power cord is not plugged in</li> <li>• Power fuse is faulty</li> </ul>
"OL" is displayed	<ul style="list-style-type: none"> <li>• The weight range has been exceeded (observe the information on the maximum weight range)</li> </ul>
"UL" is displayed	<ul style="list-style-type: none"> <li>• The weight range is below the range of the instrument (weighing pan or pan holder missing).</li> <li>• We recommend to have only the pan holder placed during switching on.</li> </ul>
The weight display changes continuously	<ul style="list-style-type: none"> <li>• The draft is too strong at the location of the instrument</li> <li>• The instrument support is vibrating or fluctuating</li> <li>• The weighing pan is touching a foreign body</li> <li>• The sample is absorbing moisture</li> <li>• The sample is evaporating/vaporising/ subliming</li> <li>• Sharp changes in temperature in the sample</li> </ul>

Fault	Possible causes
Results of weighing are clearly incorrect	<ul style="list-style-type: none"> <li>• The instrument has not been correctly tared</li> <li>• The instrument has not been correctly levelled</li> <li>• The calibration is no longer correct</li> <li>• Sharp temperature fluctuations occur</li> </ul>
Configuration menu cannot be changed	<ul style="list-style-type: none"> <li>• The data protection is activated in the configuration menu</li> </ul>
The display flashes continuously during calibration	<ul style="list-style-type: none"> <li>• The instrument location is not stable enough (interrupt calibration with «<b>ON/OFF</b>» and move the balance to a better location).</li> <li>• Use of a calibration weight which is too imprecise (only applies to external calibration)</li> </ul>
The connected printer won't work	<ul style="list-style-type: none"> <li>• The printer is not switched on</li> <li>• The data cable is faulty or not connected</li> <li>• The interface settings do not match the moisture analyzer</li> </ul>
The printer prints incorrect characters	<ul style="list-style-type: none"> <li>• The parity setting or the baud rate of the interface don't match</li> <li>• The data cable is faulty</li> </ul>
Drying won't start	<ul style="list-style-type: none"> <li>• The sample is not stable</li> </ul>

## 19.4 Customer Service

Please direct any queries or orders to:

Büchi Labortechnik AG  
P.O Box  
CH-9230 Flawil

tel. +41 71 394 63 63

fax. +41 71 394 65 65

[buchi@buchi.com](mailto:buchi@buchi.com)

<http://www.buchi.com>

## 20 Overview

### 20.1 Technical data

Heat source, heater type	Halogen / IR quartz rod / dark
Weighing range [g] / Readability [g]	124 /0.001

#### Drying:

Readability [%]	0.01
Reproducibility at approx. 1g [%]	0.2
Reproducibility at approx. 10g [%]	0.02
Sample weight [g]	0.2 - 124
Result calculations:	100 - 0 %, 0 - 100 % ATRO 100 - 999 %, ATRO 0 - 999 %, G/KG, Residual, Loss

#### Heating:

Temperature range [°C] / Increment [°C]	30 - 230 / 1
Heating methods	Standard, Boost, Soft
Intervals	3
Booster	+ 40% during 3 min
Switch-off interval [min]	0.1 - 99.9
Switch-off interval [%]	0.1 - 99.9

#### End point criteria:

Autostop [d/s]	1 - 99 / 10 - 180
Autostop [%/s]	0.1 - 99.9 / 10 - 180
Adapt Stop	x
Timer Stop [min]	0.1 - 240.0
Minimum Stop [%]	0.1 - 99.9
Stop Delay [min]	0.1 - 99.9

#### Monitoring:

Viewing window	x
Audio	x

<b>Printout:</b>	
GLP	x
Printout - Interval [min]	0.1 - 10.0
User texts	x
Freely definable formats	x
Sample numbering	x
<b>Memory capacity:</b>	
Methods (with all settings)	50
User texts	20
<b>Operation:</b>	
"Easy access" sample holder	x
Display	LCD back-lit, graphics
Keypad	4 keys and a touch-screen
Password protection	x
<b>Special features:</b>	
Initial weighing with limits / Initial weighing help	x / x
Statistics	x
Software download and update	x
<b>Calibration:</b>	
Balance	with a test weight
Temperature, fully automatic	at 100°C and 160°C
<b>Miscellaneous:</b>	
Timer for date and time	x
Interface for PCs and printers	RS232
Bus system	x
Digital I/O	optional
Anti-theft protection	Code and mechanically

## ■ 20 Overview

### Connection:

Voltage	230V or 115V Can be switched by changing the unit of heat (may only be done by Büchi service engineer)
---------	--

Frequency [Hz]	50 - 60
----------------	---------

Power consumption [W]	450
-----------------------	-----

### Dimensions:

Instrument housing (WxHxD) [mm]	210x170x340
---------------------------------	-------------

Weight [kg]	6.3
-------------	-----

## 20.2 Accessories

<b>Accessorie</b>	<b>Article number</b>
Aluminium pans (box of 80)	42553
Printer 230 V (without an interface cable)	38682
Printer 115 V (without an interface cable)	38689
Connection cable to printer	42554
Temperature adjustment tool	42555
Calibration mass	42556
Paper roll	38684
Ribbon for printer	38683
Calibration set of weights (10-100g) with calibration certificate	41795

## ■ *Index*

### **A**

Accessories 83  
Activation / Deactivation 26  
AdaptStop 52  
Adjustment, Temperature 68  
Analyze 44  
Anti-theft code 31  
Auto start 34  
Auto stop, % / s 51  
Auto stop, d / s 51

### **B**

Batch, Contents 23  
Batch, list 60  
Batch, load 44  
Baud rate 72  
Boost drying 49  
Buzzer 31

### **C**

Calibration, Adjustment 64  
Calibration, Balance 17, 65  
Cleaning 76  
Configuration, save, store, factory 28  
Connection scheme 73  
Contrast 31  
Customer Service 79

### **D**

Data protection 33  
Data transfer 72  
Date 30  
Drying 43  
Drying, start 45  
Drying, stop 46

### **E**

Encrusting of samples 41  
Error messages 78

### **F**

Factory configuration 28  
Fundamental principles 39

### **G**

GLP, Good Laboratory Practice 17

### **H**

Handshake 72  
Home Screen 27

### **K**

Key, Backspace 24  
Key, Calibration 27  
Key, Configuration 27  
Key, Drying 27  
Key, Measured Data Management 27  
Key, OK 25  
Key, Page selection 24  
Keypad 24

### **L**

Language 30  
Leveling 16  
Location 14

### **M**

Maintenance 76  
Measured Data 58  
Measured value, list 62

Measurements, Contents 23  
Method, Contents 22  
Method, list 59  
Method, load 44  
Method, setting 44, 47  
Mode PC 35

## **N**

Numerical Data Entry 25

## **O**

ON/OFF, key 24

## **P**

Parity 72  
Power connection 15  
Print format 34  
Print rate 37  
Print, Touche 24  
Protocol foot 35  
Protocol head 35

## **R**

Remote control commands 74  
Replacing the power fuse 77  
RJ45 socket 74  
RS232 Interface 38

## **S**

Safety instructions 9  
Safety measures 16  
Sample pad 41  
Sample preparation 40  
Scope of delivery 13  
Service 76  
Servicing 76

Setting the date and time 30  
Skinning over 41  
Soft drying 50  
Software update 78  
Standard drying 49  
Standby temperature 55  
Statistics 63  
Stop mode 51  
Stop mode, delay 52  
Stop mode, minimum 52  
Stop mode, time 52  
Storage 12

## **T**

Tare, key 24  
Target weight 54  
Technical data 80  
Text Entry 26  
Time 30  
Touch screen 24  
Transport 12  
Troubleshooting 78

## **U**

Units 53, 56  
Units, calculation 56  
Unpacking 11

## **W**

Warranty 8  
Working mode 32

Declaration of conformity  
Konformitätserklärung  
Declaration de conformité

We / Wir / Nous

**Büchi** Labortechnik AG  
Postfach  
CH 9230 Flawil, Switzerland

Declare, solely under our responsibility, that the product:  
erklären in alleiniger Verantwortung, dass das Produkt:  
déclarons sous notre seule responsabilité que le produit:

**Büchi** Moisture Analyzer **B-302**

On which this declaration is based, corresponds to the production model described in the type approval certificate and with the requirements of the Council Directive 89/336, 72/23 EEC as well as EN 50081-1, EN 50082-1, EN 55022 and EN61010.

auf das sich diese Erklärung bezieht, dem in der Bescheinigung über die Bauartzulassung beschriebenen Baumuster, sowie den geltenden Anforderungen der EG-Richtlinien 89/336 EWG, 72/23 EWG sowie den Europäischen Normen EN 50081-1, EN 50082-1, EN 55022 und EN61010 übereinstimmen.

auquel la présente déclaration réfère correspond à l'échantillon d'écrit dans l'attestation d'approbation de modèle, au décrets 89/336 EWG, 73/23 CEE et la norme Européenne EN 50081-1, EN 50082-1, EN 55022 et EN61010.

The manufacturer has the following technical documentation at disposal:

- Operating instructions
- Documentation of the provision for assurance conformity

Der genannte Hersteller stellt folgende technische Unterlagen zur Verfügung:

- Bedienungsanleitung
- Dokumentation der Vorkehrung zur Sicherheit der Konformität

Le fabricant tient à disposition les document techniques suivants:

- Mode d'emploi
- Prescriptions des mesures assurant la conformité

Flawil, 15.05.2003

G.Worch

Quality management

**Büchi** Labortechnik AG