



**WATER JACKETED CO2
INCUBATORS**
WITH MICROPROCESSOR CONTROL

MODELS: 2306 & 2406

INSTALLATION AND OPERATION MANUAL

Sheldon Manufacturing Inc. P.O. Box 627 Cornelius, Oregon 97113
EMAIL: tech@Shellab.com INTERNET: <http://www.Shellab.com/~Shellab>
1-800-322-4897 (503) 640-3000 FAX (503) 640-1366



LAB Online Exhibition



TABLE OF CONTENTS

SECTION 1.0	RECEIVING AND INSPECTION
SECTION 2.0	GRAPHIC SYMBOLS
SECTION 3.0	INSTALLATION
SECTION 4.0	CONTROL PANEL OVERVIEW
SECTION 5.0	OPERATION
SECTION 6.0	FYRITE CO2 CHECKING
SECTION 7.0	MAINTENANCE
SECTION 8.0	TROUBLESHOOTING
SECTION 9.0	PARTS LIST
	UNIT SPECIFICATION
	SCHEMATICS

REV 02/02
4861500

These units are CO2 Water Jacketed incubators for professional, industrial or educational use where the preparation or testing of materials is done at approximately atmospheric pressure and no flammable, volatile, or combustible materials are being heated. These units are not intended for hazardous or household locations or use.

RECEIVING AND INSPECTION









IMPORTANT: READ THIS INSTRUCTION MANUAL IMMEDIATELY.

Your satisfaction and safety require a complete understanding of this unit, including its proper function and operational characteristics. Be sure operators are given adequate training before attempting to put the unit in service. NOTE: This equipment must be used only for its intended application; any alterations or modifications will void your warranty.

- 1.1 Inspection:** The carrier, when accepting shipment, also accepts responsibility for safe delivery and is liable for loss or damage claims. On delivery, inspect for visible exterior damage, note and describe on the freight bill any damage found and enter your claim on the form supplied by the carrier.
- 1.2** Inspect for concealed loss or damage on the unit itself, both interior and exterior. If any, the carrier will arrange for official inspection to substantiate your claim. Save the shipping crate until you are sure the unit has been delivered in good condition.
- 1.3 Return Shipment:** If for any reason you must return the unit, contact your customer service representative for authorization and supply nameplate data. Please see the manual cover for information on where to contact customer service.
- 1.4 Accessories:** Make sure all of the equipment indicated on the packing slip is included with the unit. Carefully check all packaging before discarding. An accessory package is included with each unit. The unit is equipped with 6 shelves, 2 shelf stands and 1 humidity pan per chamber, 4 leveling feet and 1 supply hose kit. Units are supplied with a power cord.

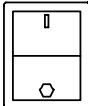
GRAPHIC SYMBOLS

Your incubator has been provided with a display of graphic symbols, which are designed to help in identifying the use and function of the available user adjustable components.

- 2.1  Indicates that you should consult your manual for further description or discussion of a control user item.
- 2.2  Indicates **"Temperature"**.
- 2.3  Indicates **"Overtemperature Safety"**.
- 2.4 °C Indicates **"Degrees Centigrade"**.
- 2.5 CO₂ Indicates **"Carbon Dioxide"**.
- 2.6  Indicates **"Gas"** (CO₂ for this unit).
- 2.7  Indicates **"AC Power ON"**.
- 2.8  Indicates **"ON/I"** and **"OFF/O"**.
- 2.9  Indicates **"Potential Shock Hazard"** behind this protective partition.
- 2.10  Indicates **"Protective Earth Ground"**.
- 2.11  Indicates **"Water Jacket Low"**.

INSTALLATION

Local city, county, or other ordinances may govern the use of this equipment. If you have any questions about local requirements, please contact the appropriate local agency. Installation may be performed by the end user.

Under normal circumstances this unit is intended for use indoors, at room temperatures between 5° and 40°C , at no greater than 80% Relative Humidity (at 25°C) and with a supply voltage that does not vary by more than 10%. Customer services should be contacted for operating conditions outside of these limits.

CAUTION: Make sure that the incubator is located in its intended position and level before filling the water jacket.

- 3.1 Power Source:** The power supply must be properly grounded (earthed) and correctly sized to match the unit data plate rating. **The supply voltage must match the data plate voltage within +/- 10%.** These units are intended for 50/60Hz application. If supplied with a detachable cord set, plug the female end into the inlet on the unit and the male plug into the supply. Assure that units requiring a fuse have a fuse installed. This fuse may be at the inlet or a part of the cord set male plug.
- 3.2 Location:** When selecting a site for the unit, consider conditions which may affect performance, such as heat from steam radiators, ovens, autoclaves, etc. Avoid direct sun, fast-moving air currents, heating/cooling ducts, and high-traffic areas. To ensure air circulation around the unit, allow a minimum of 5cm between the incubator and walls or partitions which might obstruct free airflow.
- 3.3 Lifting/Handling:** These units are heavy and care should be taken to use appropriate lifting devices that are sufficiently rated for these loads. Units should only be lifted from their bottom surfaces. Doors, handles and knobs are not adequate for lifting or transport. All moving parts, such as shelves and trays should be removed and doors need to be positively locked in the closed position during transfer to prevent shifting and damage.
- 3.4 Leveling:** The unit must sit level and solidly. Leveling feet are supplied and must be installed in the four holes in the bottom corners of the unit. With the feet installed

and the unit standing upright, each foot can be raised by turning it in a counterclockwise direction. Adjust the foot at each corner until the unit stands level and solid without rocking. If the unit must be moved, drain all the water from the jacket and turn the leveling feet all the way clockwise to prevent damage.

3.5 Cleaning: The unit chamber should be cleaned and disinfected prior to use. Your operating conditions and appropriate protocol will determine the correct procedure for decontamination. A typical decontamination procedure that is adequate for many situations has been described below. As well, certain steps are listed that will help reduce the likelihood of contamination and the necessity of decontamination. Whatever process is appropriate, it needs to be done on a regularly scheduled basis. Depending on usage and protocol, this may be monthly, quarterly or otherwise. Regardless of the decontamination procedure used, certain precautions will need to be taken:

- A.** Always disconnect the unit from the electrical service when cleaning. Assure all volatile or flammable cleaners are evaporated and dry before reconnecting the unit to the power supply.
- B.** Special care should be taken when cleaning around sensing heads to prevent damage.
- C.** If you use chlorine-based bleaches or abrasive cleaners this will modify the stainless steel interior finish. DO NOT USE hard tools such as metal wire brushes or steel wool. Use non-abrasive cleaners and soft tools such as plastic brushes.
- D.** Use only DISTILLED water in the water jacket and the humidity pan. DO NOT USE de-ionized water due to its reactivity with metal components.

TYPICAL DECONTAMINATION PROCEDURE

- 1.** Remove the humidity pan every week and autoclave, or wash with soap and water then disinfect with 70% alcohol solution. Replace in the incubator with fresh, DISTILLED water.
- 2.** Flush the sample port tubing with 70% alcohol solution. Replace any lines that have a green color.
- 3.** Remove the door gaskets, clean and disinfect. Clean and disinfect all mounting grooves for the door gaskets.
- 4.** Remove all shelves, shelf supports, shelf standards and shields. Autoclave, or wash and disinfect as described in item 1.

5. Wash and disinfect all interior surfaces.
6. Give special attention to cleaning and disinfecting all access ports, air bleeds, shaft holes, electrical pass-throughs and any other passages into the chamber.
7. Replace all air and CO₂ filters every six months or when noticeably dirty on the upstream side. CO₂ filters are located in the shadow box just behind the GAS IN fitting and in line with the CO₂ tubing kit. Units with flow meters require operator-supplied air pumps. These pumps should be checked for proper air filtering.

OPERATION FOR MINIMIZING CONTAMINATION

1. Keep the outside of the incubator, including the air in the laboratory, as clean as possible. This is particularly important for units placed directly on the floor. Do not place incubators near doors, air vents or other areas of high air movement or traffic.
 2. The floor around the unit needs to be clean. Units that are placed on the floor should be mounted higher – typically on a caster platform – for ease of moving the unit during cleaning and access to the back of the unit.
 3. Minimize the number of times access is made to the chamber during normal operation.
 4. Do not depend on the use of antibiotics to maintain uncontaminated conditions, as this is an inadequate technique for sterilization. Preferably use aseptic techniques as described above for maintaining sterile conditions in the incubator.
- 3.6 Shelves and Interior Parts:** Shelving, clips and a humidity pan are supplied with each unit. See **Figure 1** for proper placement of these accessories. Also see similar shelf assembly instructions sent with the accessory kit.

Figure 1

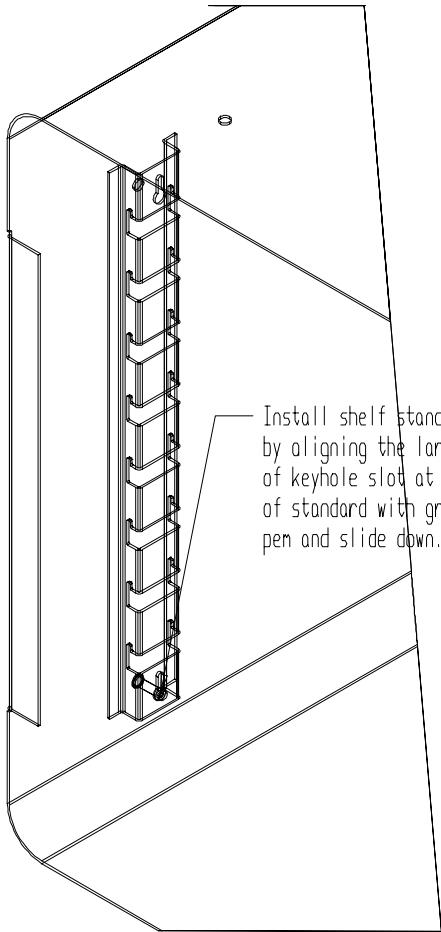

Install shelf standard by aligning the large end of keyhole slot at both ends of standard with groove in pen and slide down.

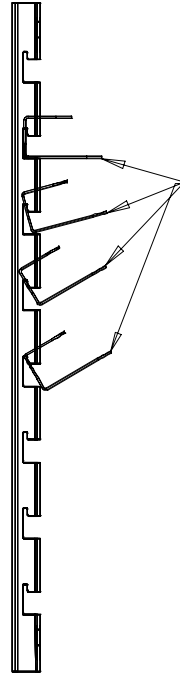

Align shelf slider between shelf standard and slide into place at a slight angle in shelf standard slots. Then lift and rotating into place until base of slide is parallel to liner bottom. As illustrated from the bottom up.

CONTROL PANEL OVERVIEW (See Figure 2)

Units with a detachable cord have a fused inlet located at the top rear of the control panel. This inlet has a recessed male plug, fuse, and an EMI filtering system designed to filter out electrical interference. This inlet also prevents any internally generated interference from feeding out to the power grid. All controls are located on the front panel, except the Over Temperature Safety which is located at the back and the Door Temperature Controller which is located on the liner of the outer door.

- 4.1 Power Switch:** The I/O (ON/OFF) switch controls all of the power for the incubator and must be in the I/ON position before any systems are operational. Both Temperature and CO₂ displays will illuminate when the power switch is in the ON position.
- 4.2 Water Low Light:** This pilot lamp is on whenever the internal water jacket float switch has been tripped to the closed position. When the water drops low enough the float switch closes the circuit turning on the indicator light.
- 4.3 Safety Activated light:** This pilot lamp is on whenever the Over Temperature Safety thermostat has been activated and taken control of the element. During normal operating conditions this indicator light should never be on.
- 4.4 Temperature Control:** This controller is marked C° and indicates the actual temperature within the chamber to .1°C. The UP/DOWN buttons are used for inputting the set point, calibrating the display, and muting or unmuting the audible alarm. The HIGH and LOW alarm indicators will light whenever there is an alarm condition associated with the temperature within the chamber. The MUTE indicator will light whenever the audible alarm has been deactivated.
- 4.5 Heating Light:** This pilot lamp is on whenever the Temperature Controller has activated the heating elements to reach and maintain set point.
- 4.6 CO₂ Control:** This controller is marked %CO₂ and indicates the %CO₂ content within the chamber to .1%. The UP/DOWN buttons are used for inputting the set point, calibrating the display, and muting or unmuting the audible alarm. The HIGH and LOW alarm indicators will light whenever there is an alarm condition associated with the CO₂% within the chamber. The MUTE indicator will light whenever the audible alarm has been deactivated.

- 4.7 Injection Light:** This pilot lamp is on whenever the CO₂ controller is injecting the CO₂ into the chamber.
- 4.8 Over Temperature Safety Control (OTP):** Located at the back of the control panel adjacent to the power inlet. This is a hydraulic thermostat that is wired between the Main Temperature Control and the heating element and functions as an override control. If at any time the Temperature Control fails in the ON position and the temperature in the chamber rises above its set point, the OTP is activated and maintains temperature at its own set point. Note that the HEATING indicator will continue to function under the control of the OTP. It is not recommended that the unit be allowed to operate for an extended period of time using only OTP as temperature uniformity will suffer.
- 4.9 Door Temperature Control:** This is located on the outer door liner in the upper left corner. This control will maintain the door temperature between 1° and 1.5°C above the incubator chamber temperature to prevent condensation from forming on the glass door.
- 4.10 CO₂ Sample Port:** This is located in the upper front corner of the right side of the incubator. A sample can be drawn to measure the CO₂ content in the chamber at this port.

Figure 2

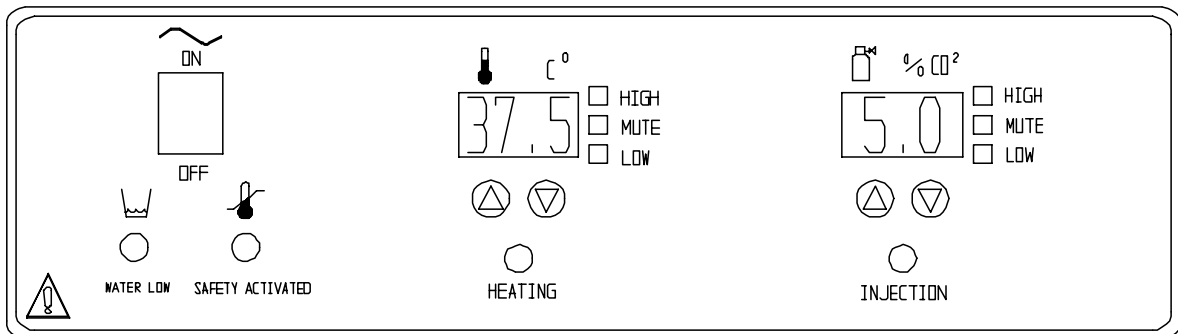

45006B1

OPERATION

READ THIS SECTION IN ITS ENTIRETY BEFORE ATTEMPTING OPERATION

IMPORTANT: In order to assure the proper operation of this incubator, it is essential that you regularly verify the accuracy of the temperature and CO₂ controls. Temperature can be confirmed by use of a thermometer inside of the chamber. CO₂ can be confirmed with the use of a FYRITE Gas Analyzer or other equipment such as a gas chromatograph. These must be checked at least on a weekly basis. Any questions should be directed to a technical service representative. The temperature, and CO₂ were calibrated at the factory prior to shipment.

- 5.1** Power up the unit by attaching the cord set (supplied with the accessories) to the unit inlet and the building power supply. Attach the female end of the cordset into the fused and recessed male plug on the rear of the unit and the male plug end of the cord set into the building supply receptacle. Turn the power switch to the I/ON position.
- 5.2 Filling and Draining the Jacket:** The front panel of the incubator has a WATER LOW warning light. Fill the water jacket with DISTILLED WATER by means of the fill port located at the top right rear of the unit marked FILL WJ HERE. Stop filling when the WATER LOW warning light goes off. When full the unit holds 19.0 U.S. gallons (72 Liters) in the chamber. To drain the unit, hook a suitable hose to the siphon tube located to the left of the fill port and marked SIPHON HERE. Start a siphon and allow the water to empty into a suitable service drain or catchment area.
- 5.3 Setting the Controls:** Imputing the set point on any of the controls is a very easy operation.
 - A.** Push and release either the "UP or "DOWN" button and the digital display will start to blink from bright to dim.
 - B.** While the display is blinking it will show the set point, which can be changed using the "UP", or "DOWN" buttons.
 - C.** If no buttons are pressed within five (5) seconds the blinking light will stop and the display will revert to showing the process or actual parameter within the incubator chamber.
- 5.4 Calibrating the Controls:**

- A. Push and hold both the UP and DOWN buttons until the decimal points in the display begin to blink.
- B. While the decimal points are blinking the UP and DOWN buttons can be used to adjust the display to match the actual condition in the incubator chamber.
- C. If no buttons are pressed within five (5) seconds the blinking will stop and the display will revert to showing the process or actual parameter within the incubator chamber.

5.5 Humidification: Humidification of the unit is achieved by evaporation of water from the chamber humidity pan placed in the bottom of the incubator. By filling this stainless steel reservoir pan with DISTILLED WATER and allowing this water supply to heat and evaporate, near saturation humidity is obtained. Do not use plastic, glass or other metals. Only 300 series stainless metals are acceptable for this reservoir pan. Do not use corrosive chemicals, including copper sulphate or chlorine, in the pan or chamber as damage may occur. **Use Distilled Water Only.**
Do NOT use Deionized Water!

Use of disinfecting chemicals in the chamber can change the surface tension of the reservoir water thus preventing evaporation and proper humidification of the chamber. Water in the pan should be changed and the pan cleaned at least once a week to help control contamination and maintain proper surface tension.

5.6 Temperature Monitoring: To insure that the incubator is operating at the desired temperature, an accurate temperature indicator such as a certified reference thermometer should be placed in the incubator chamber. Try to place the thermometer in the center of the chamber and raised off the shelf (taping the thermometer down to a petri dish is a method that raises it off the shelf and prevents it from rolling and hiding the scale from view). A second thermometer can be taped to the center of the door liner to measure the door liner temperature. For ease of reading both thermometers, it would be better if they were electronic with a remote display so they can be read without opening the doors. When using a single thermometer, the internal temperature should be monitored first and accuracy verified, then the door liner and its accuracy verified.

5.7 Initial Control Settings: Set the controls to the set points you want your incubator to operate at.

- A. Set the over temperature safety to its maximum position clockwise. Allow the incubator to warm up and stabilize for 24 hours after making the initial control settings.

- B. All units are shipped set for 37°C and 5.0% CO₂. If other conditions are desired follow the instructions in section 5.3 for resetting controls.
- C. If 37° is the internal temperature desired then the door control should be set to the 38° guide mark on the door liner.

5.8 Temperature Calibration: It is important that the calibration be performed in the following order: Main temperature, door temperature, then the over temperature safety.

- A. During main temperature calibration it is important that the inner glass door not be opened for any reason, and that the outer heated door be opened as little as possible.
- B. After the incubator has been running for 24 hours and the temperature display is stable at the set point, read the temperature in the incubator chamber from the reference thermometer and, if necessary, recalibrate the display using the instructions in section 5.4.
- C. After the main temperature display has restabilized and maintained set point for several hours, check the actual temperature again. If it does not match the display, repeat the calibration process again.
- D. When the display and actual temperatures match, check the door temperature. If using a glass thermometer taped to the center of the door liner, then the door must be opened and the thermometer read **very quickly** before it drops due to the cooler room temperature. The door temperature should be 1° to 1.5°C above the Main temperature. If it is not, then adjust the door control slightly UP or DOWN, and wait several hours before checking again.
- E. After the door and Main temperatures are set and adjusted, the over temperature safety control needs to be set. Do this by turning the Safety counterclockwise until the SAFETY ACTIVATED indicator light comes on. Next slowly turn the control knob clockwise until the indicator light turns off. Then turn clockwise two of the smallest divisions on its scale past the point where the indicator went out. This will set the Over Temperature Safety at approximately 1°C above the Main Temperature Controller.

5.9 CO₂ Supply System and Control System: The CO₂ system is rated for pressures between 5 and 40 PSI, which should never be exceeded at any time. Prior to any attempt to hook up or run the CO₂ Control System, the water jacket must be filled and the temperatures adjusted as noted in Section 5.7 and 5.8.

Figure 3

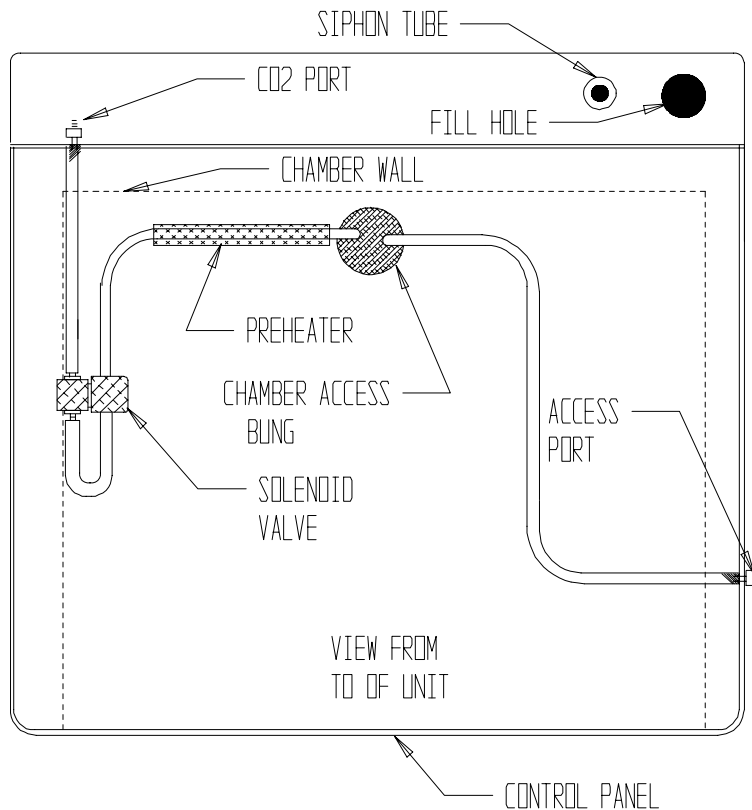

9850677

- A.** The CO2 inlet fitting is located on the back of the incubator near the top (**see figure 3**). It is marked "CO2 TO CHAMBER". The supply hose with in-line CO2 filter (supplied with your accessories) connects from this fitting to the CO2 tank and regulator. The initial supply pressure should be 20 PSI.
- B.** It is highly recommended that a good quality **DUAL STAGE** pressure regulator be used on the CO2 tank. The dual stage regulator will have two pressure gauges with a 0-60PSI **LOW-PRESSURE** range. The high pressure gauge will indicate the pressure within the tank. The low pressure gauge will indicate the pressure on the supply hose to the incubator. Do not use single stage regulators. A two gauge regulator is not necessarily a dual stage regulator. **Insure that you are using a dual stage regulator.**
- C.** It is normal for the high pressure gauge on your regulator to start out reading

800 to 1000 PSI with a full tank. This reading will drop to 500 to 800 PSI quickly and will stay there for most of the duration of the tank. At the end of use, the pressure will drop quickly to zero, indicating that the tank is completely empty. Pure CO₂ is in a liquid state in the new tank and a constant vapor pressure is generated in the tank above the liquid level, and the CO₂ is drawn from the top as a gas. This same vapor pressure is maintained as long as any liquid is left in the tank. When the last of the liquid has evaporated into gas then the pressure will drop rapidly as the gas is drawn off.

- D. Only medical grade CO₂ should be used in your incubator. The use of a lesser grade may damage your incubator and void your warranty.
- E. The microprocessor CO₂ control system interprets the information from the CO₂ sensor, displays the CO₂ concentration directly on the digital display, reads the CO₂ set point, and controls the percentage of CO₂ in the incubator chamber.
- F. There are two types of CO₂ sensors available, Thermal Conductivity (TC) and Infrared (IR). The 2306 units operate with TC sensors, and the 2406 units operate with IR sensors.
- G. TC sensors operate under the principle that CO₂ is 1.5 times denser than air and if you measure the changes in density they can be interpreted as changes in CO₂ content. This method of measurement is accurate, reliable and stable as long as all factors that influence air density are maintained unchanged. Factors that effect density are humidity and temperature. When the door of the incubator is opened, the humidity is reduced, the temperature is lowered and the thermal conductivity control system loses stability until the conditions in the incubator have recovered to original conditions.
- H. IR sensors operate under the principle that a certain frequency of infrared light is absorbed by CO₂. The more CO₂ is present the more light is absorbed. Advantages to this system are that it is only sensitive to CO₂, so its accuracy is consistent no matter what the conditions are in the incubator.
- I. Both types of CO₂ sensors are factory calibrated and under normal circumstances need no calibration in the fields; however, it is recommended that the accuracy of your CO₂ control system be monitored by measuring the actual CO₂ concentration on a weekly basis with a FYRITE or other measuring device. This should be done when the chamber has not been disturbed for an extended period of time, i.e. after the weekend or first thing on Monday morning.

5.10 Setting the CO₂ Control: Attach the supply hose to the incubator and turn on the

CO2 supply. Set the CO2 control to the desired set point using the procedure described in section 5.3.

5.11 Adjusting CO2 Display: After the incubator has had several hours to stabilize at CO2 set point, measure the actual CO2% with a Fyrite. If there is any difference between the Fyrite and the display, use the procedure described in section 5.4 for making the display match the Fyrite. See Section 6.0 for Fyrite use.

NOTE: When using the Fyrite, insure that gas is not being injected while the reading is being taken. Change the CO2 set point to 0.0 prior to taking the sample and then change the set point back to the desired value after the use of the Fyrite.

5.12 Alarm Conditions: The temperature control and the CO2 control are both equipped with visual and audible alarms.

- A. Temperature Alarms:** The temperature control has alarm indicators for high and low conditions that are activated whenever the actual temperature is 1C° above or below the set point.
- B. CO2 Alarms:** The CO2 controller has alarm indicators for high and low alarm conditions that are activated whenever the actual CO2% is 1% above or below the set point.
- C. Audible Alarms:** Both controls are equipped with audible alarms that are activated when either of the HIGH or LOW indicators are activated. The audible alarms can be muted for a single alarm occurrence by pressing and holding down either the UP or DOWN button for several seconds until the MUTE light comes on. There is a built in delay of 15 minutes on the occurrence of a LOW alarm. This prevents the audible alarm from activating every time the door is opened and the temperature and CO2 drops.

FYRITE CO₂ CHECKING

A Bacharach FYRITE CO₂ Gas Analyzer is recommended to measure CO₂ concentrations in the incubator chamber. This test instrument is not supplied with the incubator but is readily available from your dealer. Follow the instructions provided with the Fyrite instrument carefully to insure correct and accurate readings.

1. Press button on top of Fyrite canister to release CO₂ concentration. Tip canister to the side to ensure all fluid is released from the top of canister.
2. Loosen screw on slide scale and align top of fluid with zero on the scale. Tighten screw.
3. Connect hose and aspirator bulb to unit being tested. The sample port for connection is located in the upper front corner of the right side of the incubator.
4. Place the hose sampling cap directly over the plunger valve on top of canister and depress firmly.
5. With button depressed, squeeze bulb 27 times. On the last squeeze and with bulb still deflated, release hose from button.
6. Turn Fyrite canister upside down 3 times, each time allowing all fluid to flow to the opposite end of the canister.
7. Tip canister to the 45 degree position to ensure all fluid has been released from top of canister.
8. Read CO₂ concentration in %.

NOTE: Your Fyrite indicator will come with a complete set of detailed instructions which should be followed carefully. The fluid used inside this Fyrite instrument is poisonous and corrosive and must not be taken internally. In event of a spill or accidental body contact with the Fyrite fluid, follow instructions on the refill bottle carefully.

MAINTENANCE

NOTE: Prior to any maintenance or service on this unit, disconnect the service cord from the power supply.

- 7.1 Cleaning:** Cleaning and decontamination are recommended on a regular basis. To prepare the incubator for cleaning remove all parts such as the shelves, shelf standards and false ceiling. All stainless steel parts are autoclavable. Please review the cleaning procedures described in the Installation section for detailed instructions.
- 7.2** Check CO₂ supply periodically; do not let it run out. (Automatic tank switches are available from your dealer.)
- 7.3** CO₂ supply lines and connections can be checked for leaks with a liquid soap solution. Apply a liquid soap solution to all areas of the CO₂ supply line and then look for bubbles which will indicate a leak.
- 7.4** Keep the CO₂ flow system free of impurities. Erratic CO₂ control is usually traceable to the CO₂ pressure regulator on the tank, impurities in the tank, or impurities in the solenoid valve. Replace the CO₂ in-line filter every six (6) months or when the filter has become noticeably dirty on the upstream side. There is a CO₂ filter attached to the tubing kit, and one inside the shadow box connected to the GAS-IN line.
- 7.5 Storage:** If the incubator is to be turned off for any length of time, dry the chamber and humidity pan thoroughly and leave at room temperature. Failure to do this may cause the interior to become contaminated. No adjustment to controls should be required when restarting the unit. If you intend to shut the unit down for transport, dry the chamber completely, remove the humidity pan and shelving, disconnect the CO₂ supply and power cord, drain the water jacket and screw in the leveling feet. See Section 3.3 Lifting / Handling, for transport procedures.
- 7.6** There is no maintenance necessary for controls. If controls fail to operate as specified, review Section 8.0 Troubleshooting, before calling for service.

TROUBLESHOOTING

CAUTION: Extreme caution must be exercised any time access is made into areas housing electrical components. Repair, replacement or adjustment of components in these areas must only be done by qualified technicians familiar with electrical circuitry and the operation of the chamber.

Always make a visual inspection of the incubator and control console when troubleshooting. Look for loose or disconnected wires or tubing, which may be the source of the trouble.

NOTE: IF BREAKERS TRIP REPEATEDLY, OR FUSES BLOW REPEATEDLY, CALL QUALIFIED SERVICE PERSONNEL.

TEMPERATURE

Temperature too high

- 1/ controller set too high-see section 5.3
- 2/ controller failed on – call Customer Service
- 3/ wiring error – call Customer Service

Display reads "HI" or "400"+

probe is unplugged, is broken or wire to sensor is broken – trace wire from display to probe; move wire and watch display to see intermittent problems

Chamber temp spikes over set point and then settles to set point

recalibrate – see section 5.4

Temperature too low

- 1/ OTP too low – see section 5.8.E
- 2/ controller set too low – see section 5.3
- 3/ unit not recovered from door opening – wait for display to stop changing
- 4/ unit not recovered from power failure or being turned off – incubators will need 24 hours to warm up and stabilize
- 5/ element failure – see if heating light is on; compare current draw to data plate
- 6/ controller failure – confirm with front panel lights that controller is calling for heat
- 7/ OTP failure – confirm with front panel lights that it is operating correctly

	<p>8/ wiring problem – check all functions and compare wiring to diagram in section 10.0, especially around any areas recently worked on</p> <p>9/ loose connection – check shadow box for loose connections</p>
<p>Display reads "LO"</p>	
	<p>1/ sensor is plugged in backwards – reverse sensor wires to controller</p> <p>2/ if ambient room temperature is lower than range of unit – compare set points and ambient temperature to rated specifications in section 9.0</p>
<p>Unit will not heat over a temperature that is below set point</p>	
	<p>1/ confirm that fan is moving and that amperage and voltage match data plate – check fan motor motion in shadow box and feel for air movement in chamber</p> <p>2/ confirm that set point is set high enough ,turn OTP counterclockwise and see if heating light or safety light comes on</p> <p>3/ check connections to sensor</p> <p>4/ check calibration – using independent certified reference thermometer, follow instructions in sections 5.4 and 5.8</p>
<p>Unit will not heat up at all</p>	
	<p>1/ verify that controller is asking for heat by looking for controller light – if pilot light is not on continuously during initial start up there is a problem with the controller</p> <p>2/ check amperage – amperage should be virtually at maximum rated (data plate) amperage</p> <p>3/ do all controller functions work?</p> <p>4/ is the OTP set high enough? – for diagnostics, should be fully clockwise with the pilot light never on</p> <p>5/ has the fuse/circuit breaker blown?</p>
<p>Indicated chamber temperature unstable</p>	
	<p>1/ ± 0.1 may be normal</p> <p>2/ is fan working? – remove top panel and verify movement of cooling fan in center of shadow box</p> <p>3/ is ambient room temperature radically changing – either door opening or room airflow from heaters or air conditioning? – stabilize ambient conditions</p> <p>4/ sensor miss-located, damaged, or wires may be damaged - check mounts for control and OTP sensors, then trace wires between sensors and controls</p> <p>5/ calibration sensitivity – call Customer Service</p> <p>6/ OTP set too low – be sure that OTP set point is more than 5 degrees over desired Main set point; check if OTP pilot is on continuously; turn controller knob completely clockwise to see if problem solved then follow instructions in section 5.8.E for correct setting.</p> <p>7/ electrical noise – remove nearby sources of RFI including motors, arcing relays or radio transmitters</p> <p>8/ bad connection on temperature sensor or faulty sensor – check connectors for continuity and mechanical soundness</p>

while watching display for erratic behavior; check sensor and wiring for mechanical damage
9/ bad connections or faulty capacitor – check connectors for mechanical soundness and look for corrosion around terminals or signs of arcing or other visible deterioration

Will not maintain set point

- 1/ assure that set point is at least 5 degrees over ambient room temperature
- 2/ see if ambient is fluctuating

Display and reference thermometer don't match

- 1/ calibration error – see section 5.4
- 2/ temperature sensor failure – evaluate if pilot light is operating correctly
- 3/ controller failure – evaluate if pilot light is operating correctly
- 4/ allow at least two hours to stabilize
- 5/ verify that reference thermometer is certified

Can't adjust set points or calibration

- 1/ turn entire unit off and on to reset
- 2/ if repeatedly happens, call Customer Service

Calibrated at one temperature, but not at another

This can be a normal condition when operating temperature varies widely. For maximum accuracy, calibration should be done at or as close to the set point temperature.

CO2 LEVEL

Overshoots set point but stabilizes - display and Fyrite match

- 1/ turn set point up and down to see if solenoid valve works by feeling and listening to valve
- 2/ recalibrate with Fyrite, see section 5.4 and section 6.0
- 3/ fan not operating correctly
 - a- fan motor stopped
 - b- fan blade fell off
 - c- wrong fan blade installed or mounted backwards
- 4/ wrong restrictor installed or missing altogether
- 5/ tank pressure too high, see section 5.9.A
- 6/ CO2 sensor partially plugged with dirt or condensation
- 7/ regulator set wrong, see section 5.9
- 8/ incubator too heavily loaded
- 9/ incubator being operated without shelving
- 10/ CO2 attached to sample port instead of "CO2 IN" fitting
- 11/ if display and Fyrite does not match, see below

Overshoots set point and continues to rise - display and Fyrite match

- 1/ debris in solenoid causing it to leak continuously
- 2/ solenoid failed while open
- 3/ unit miss-wired
- 4/ controller output failed or shorted
- 5/ CO2 sensor or interface failure

6/ CO2 sensor plugged by debris or condensation

Rises very slowly

- 1/ restrictor partially plugged
- 2/ filter overly dirty or partially plugged
- 3/ CO2 tank regulator set too low, see section 5.9
- 4/ hose kinked or leaking
- 5/ poor door seal
- 6/ CO2 tank contains mixed gas, not 100% medical grade CO2

Never rises

- 1/ CO2 tank empty
- 2/ solenoid failed while closed
- 3/ CO2 controller output failed while open
- 4/ restrictor plugged
- 5/ CO2 hose blockage
- 6/ CO2 filter plugged
- 7/ set point is at 0.0 and has not been reset, see section 5.3 and 5.4

Display and Fyrite reading do not match

- 1/ calibration error - clear chamber for 12 hrs and confirm at "0"
- 2/ turn set point up and down to see if solenoid valve works by feeling and listening to valve
- 3/ assure that IR tube block is completely tight, 2406 units
- 4/ if display is varying when doing Fyrite test, have a leak on IR base or mounting plate, or CO2 is injecting at time of test.
- 5/ take voltage reading across sensor leads 0=0V and 20=1V
- 6/ assure that sensor is properly mounted
- 7/ DISPLAY LOWER THAN FYRITE: air leak around the CO2 sensor or the fan motor shaft
- 8/ DISPLAY HIGHER THAN FYRITE: leak in tube from sample port to chamber, verify with liquid soap solution.
- 9/ DISPLAY HIGHER THAN FYRITE: Fyrite fluid worn out, replace fluid with Fyrite refill.
- 10/ DISPLAY HIGHER THAN FYRITE: poor Fyrite sampling technique, see section 6.0
- 11/ DISPLAY HIGHER THAN FYRITE: defective Fyrite pump or tubing
- 12/ CO2 sensor, interface or controller failure

Is unstable – display or actual reading varies around set point

- 1/ confirm that fan is working
- 2/ check for air leak around CO2 sensor or fan motor shaft
- 3/ magnetic field interference
- 4/ door not sealing properly
- 5/ atmospheric pressure fluctuations
- 6/ defective Fyrite pump or tubing
- 7/ CO2 entering chamber too quickly
 - a- tank pressure too high
 - b- regulator set wrong
 - c- restrictor incorrect or missing
- 8/ electronic problem with CO2 sensor, interface or controller

- 9/ top of unit exposed to cold air drafts
- 10/ unit being operated without shadow box cover
- 11/ electrical interference – atmospheric or conducted
- 12/ Incubator too heavily loaded

Can't adjust set points or calibration -
"locked up"

- 1/ turn unit off and on to reset processor in controller
- 2/ if repeatedly happens, call Customer Service

Feeding continuously or abnormally
high CO2 usage

- 1/ do decay test: if more than 1% decay in an hour, check for leak : door gasket tightness, motor inlet to chamber, sensor and probe inlet to chamber
- 2/ check output signal from controller
- 3/ check solenoid valve for correct operation
- 4/ leak in plumbing including between regulator and CO2 tank
- 5/ door being opened too often

Won't hold calibration – Fyrite reading
varies but display stable

- 1/ atmospheric pressure fluctuations
- 2/ top of unit exposed to cold air drafts
- 3/ unit being operated without shadow box cover in place
- 4/ condensation collecting on CO2 sensor
- 5/ CO2 sensor or interface failure
- 6/ unit incorrectly calibrated, see section 5.4
- 7/ taking Fyrite reading too soon after the door has been opened
- 8/ air leak around CO2 sensor mounting plate

MECHANICAL

Door not sealing

- 1/ check physical condition of gasket
- 2/ confirm that door latch pulls door in tightly
- 3/ assure that gasket is in original location

Motor doesn't move

- 1/ if shaft spins freely: check connections to motor and check voltage to motor;
- 2/ if shaft rubs or is frozen, relieve binding and retest

Motor makes noise

- 1/ If noise is from the motor, tap the top of motor shaft with ball peen hammer.
- 2/ If the sound gets worse, tap the other end of the shaft - avoiding touching the fan blade.
- 3/ If there is no change, call Customer Service.
- 4/ If noise is from shaft or fan blade, realign shaft.

Solenoid valve buzzing

After removing solenoid clean with alcohol for carbon build-up then blow out. Check valve seat or channels for contamination. Check CO2 filter and/or grade of CO2 used. If seat is worn, replace.

OTHER

Controller on at all times - "locked-up"

- 1/ turn unit off and on to reset
- 2/ if cannot change any condition on the front panel, call Customer Service

Front panel displays are all off

- 1/ Check for wire damage.

Unit or wall fuse/circuit breaker is blown

- 1/ check wall power source
- 2/ compare current draw and compare to specs on data plate
- 3/ see what other loads are on the wall circuit

Unit will not turn on

- 1/ check wall power source
- 2/ check fuse/circuit breaker on unit or in wall
- 3/ see if unit is on, e.g., fan or heater, and just controller is off
- 4/ check all wiring connections, esp. around the on/off switch

Unit is smoking – Out of box

- Put unit under vent and run at full power for one hour.

Contamination in chamber

- 1/ see cleaning procedure in Installation section 3.0
- 2/ develop and follow Standard operating procedure for specific application; include definition of cleaning technique and maintenance schedule.

NOTE: THE TEMPERATURE OF THE GLASS DOOR AND THE INTERIOR CHAMBER WALLS MUST BE EQUAL TO PREVENT CONDENSATION.

The incubator is designed so that no internal electrical servicing should be required under normal conditions. If electrical servicing is necessary, it should be performed by qualified service personnel. **FOR PERSONAL SAFETY, ALWAYS DISCONNECT THE POWER BEFORE SERVICING.** For information on where to contact Customer Service, please see the manual cover.

Section**9****PARTS LIST**

Description	115V	220V
CO2 Control w/Alarm	1750559	1750560
CO2 Filter	100199	100199
Cord Set	1800510	104192
Door Control	100001	100001
Door Heater	103068	103068
Element Coil	2350503	120071
Fan Blade	103130	103130
Fan Motor	4880508	4880507
Gasket, 8 feet	3450534	3450534
Glass Door Latch	9530516	9530516
IR Transmitter, 2406 units	8320501	8320501
Over Temperature Safety	100001	100001
Pilot Light, Green	200021	200021
Pilot Light, Red	200020	200020
Power Inlet Fuse	103558	103588
Power Switch	103351	103351
Solenoid Valve	100016	410154
TC CO2 Sensor w/Interface, 2306 units	9700501	9700501
Temperature Control w/Alarm	1750557	1750558
Transformer, 2406 units	6750502	NA

UNIT SPECIFICATIONS

These units are 115 volt or 220 volt. Please refer to the unit data plate for its individual specification.

Weight	Shipping	Net
2306	280 lbs.	221 lbs.
2306/2	600 lbs.	442 lbs.
2406	280 lbs.	221 lbs.
2406/2	600 lbs.	442 lbs.

Dimensions	Exterior WxDxH (IN.)	Interior WxDxH (IN.)
2306	26.5x26x40	33x33x47
2306/2	26.5x26x80	20.5x20x28
2406	26.5x26x40	26.5X26X40
2406/2	26.5x26x80	26.5X26X40 (x2)

Capacity	Cubic Feet
2306	6.7
2306/2	6.7 (x2)
2406	6.7
2406/2	6.7 (x2)

Temperature	Range	Uniformity	CO2
2306	Amb. 5°C to 60°C	±0.1°C @ 37°C	0 – 20%
2306/2	Amb. 5°C to 60°C	±0.1°C @ 37°C	0 – 20%
2406	Amb. 5°C to 60°C	±0.1°C @ 37°C	0 – 20%
2406/2	Amb. 5°C to 60°C	±0.1°C @ 37°C	0 – 20%

WIRING DIAGRAM 2306 & 2306/2

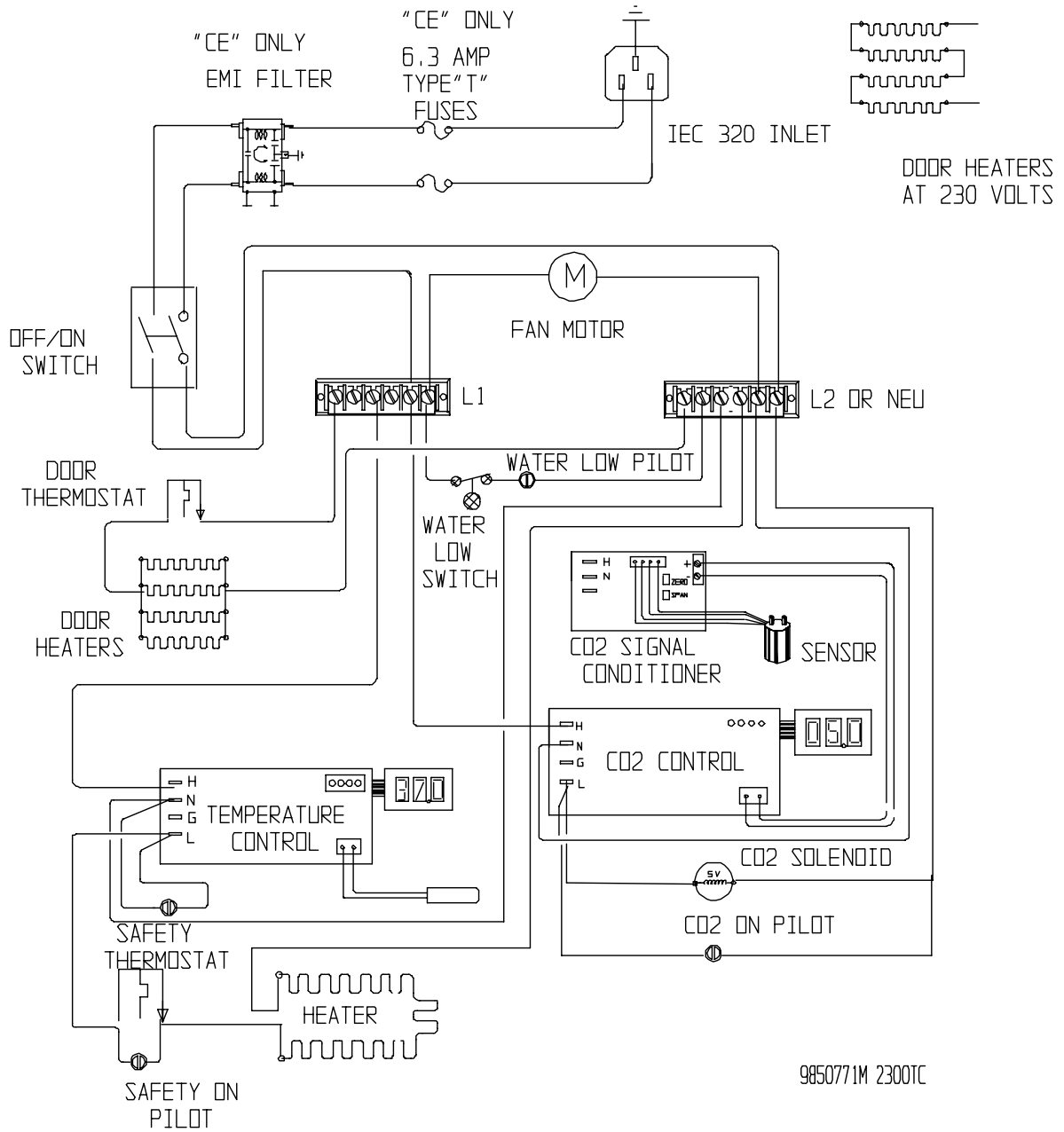

WIRING DIAGRAM 2406 & 2406/2

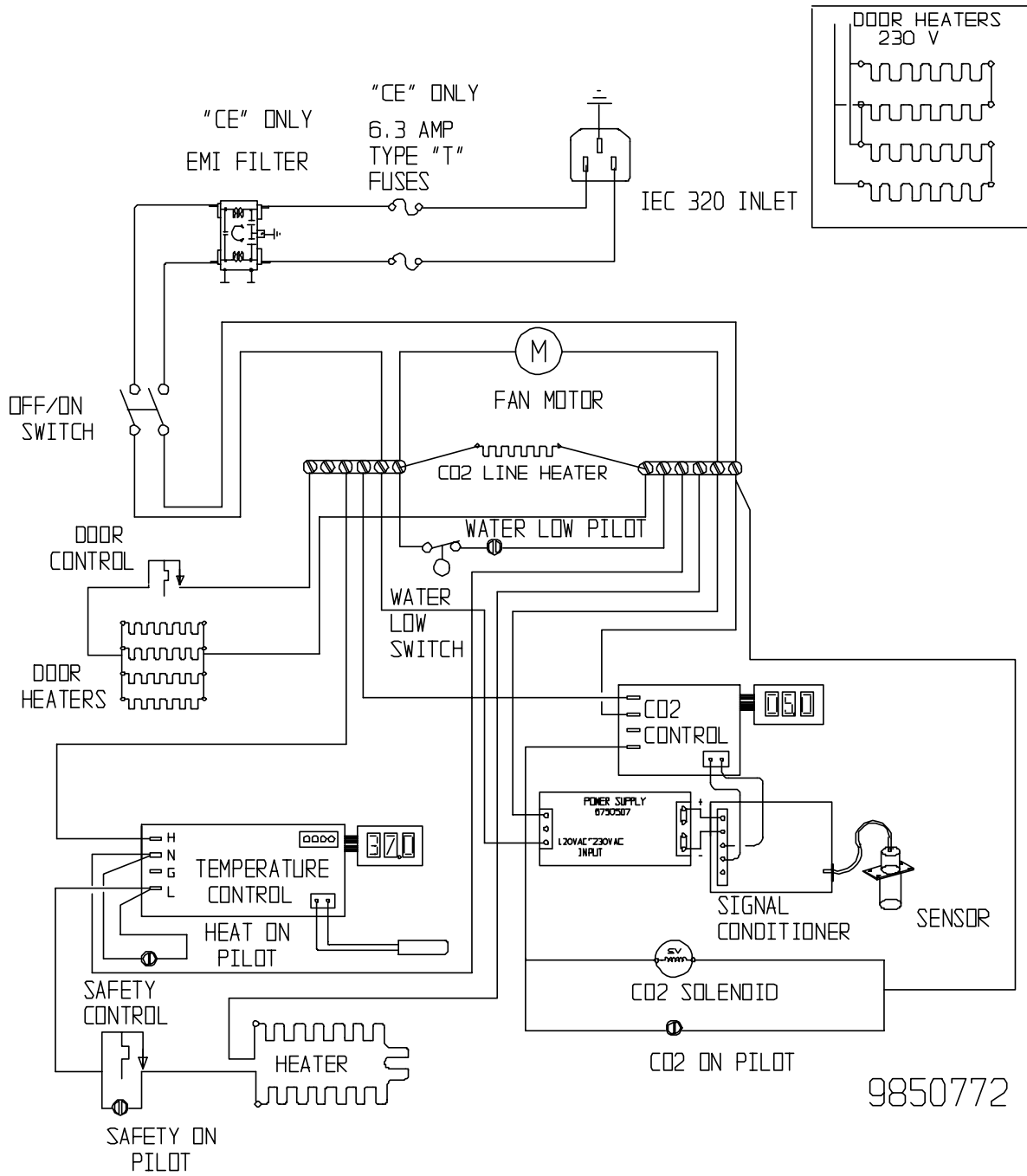

9850772