

BRANSONIC[®]

ULTRASONIC CLEANERS

OPERATOR'S MANUAL

**MODELS
1200, 2200, 3200, 5200, 8200**



LAB Online Exhibition



ULTRASONIC CLEANING

How it works

Ultrasonic sound is sound transmitted at frequencies beyond the range of human hearing. Your Branson Ultrasonic Cleaner operates at ultrasonic frequencies for cleaning.

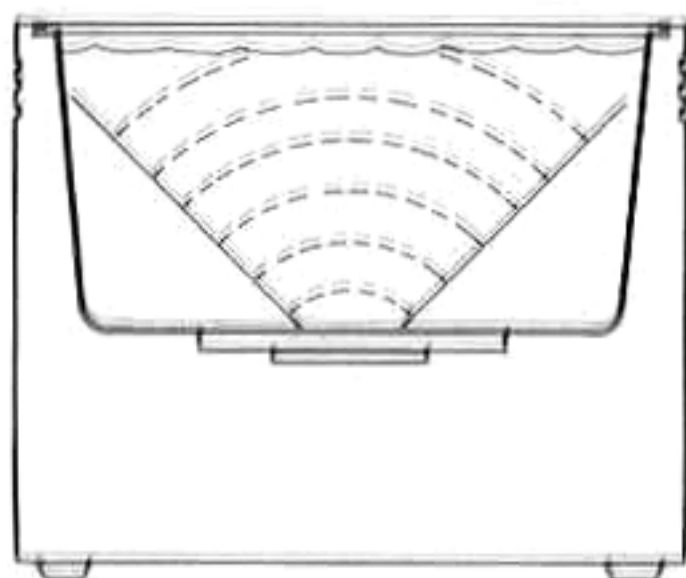

As the sound waves from the transducer radiate through the liquid in the tank, they cause alternating high and low pressures in the liquid.

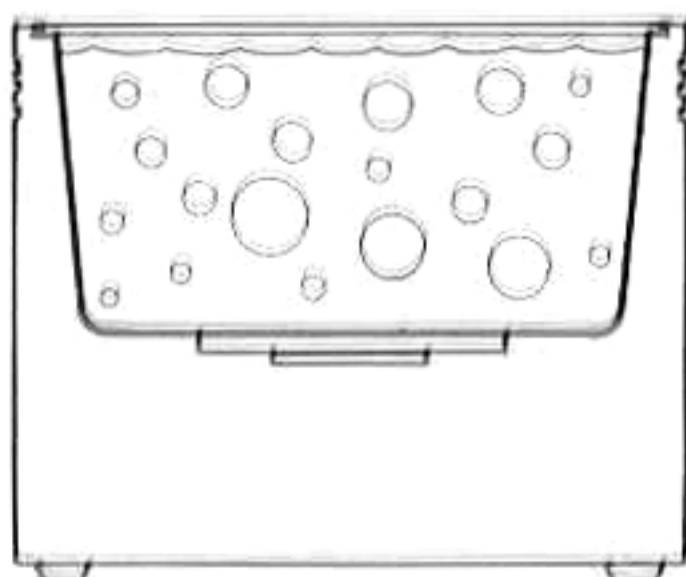

During the low pressure stage, millions of bubbles form and grow. This process is called CAVITATION, meaning "formation of cavities".

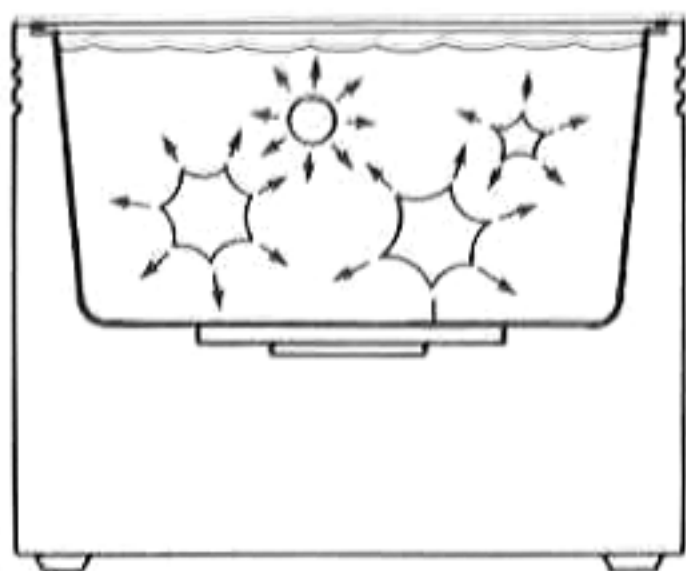

During the high pressure stage, the bubbles collapse, or "implode", releasing enormous amounts of energy. These implosions act like an army of tiny scrub brushes. They work in all directions, attack every surface and invade all recesses and openings.

Ultrasonic cleaning is very effective for cleaning hard materials but less effective for cleaning soft or porous materials. The harder the surface, the more effective the sonic scrubbing action. Since metals, glass, ceramics and hard plastics conduct sound, they are ideal candidates for ultrasonic cleaning.

ACHIEVING THE BEST RESULTS

Determine the right cleaning method

Several important factors affect the operation of your Branson Ultrasonic Cleaner and should be considered in order to achieve the best cleaning results.

There are two methods of cleaning — direct and indirect. Each has advantages and disadvantages. When in doubt, test run samples using both methods to determine which one produces the best results.

Direct method

The direct method is very satisfactory for many cleaning jobs. In this method:

- The cleaning solution is poured directly into the tank.
- The items to be cleaned are placed in a perforated tray and lowered into the tank. Items also can be suspended on a wire and submerged in the solution.

The advantages of the direct method are its simplicity of operation and its cleaning effectiveness. However:

- All removed soil remains in the tank.
- Only one solution can be used at a time.
- Highly acidic or caustic solutions can erode the tank surface.

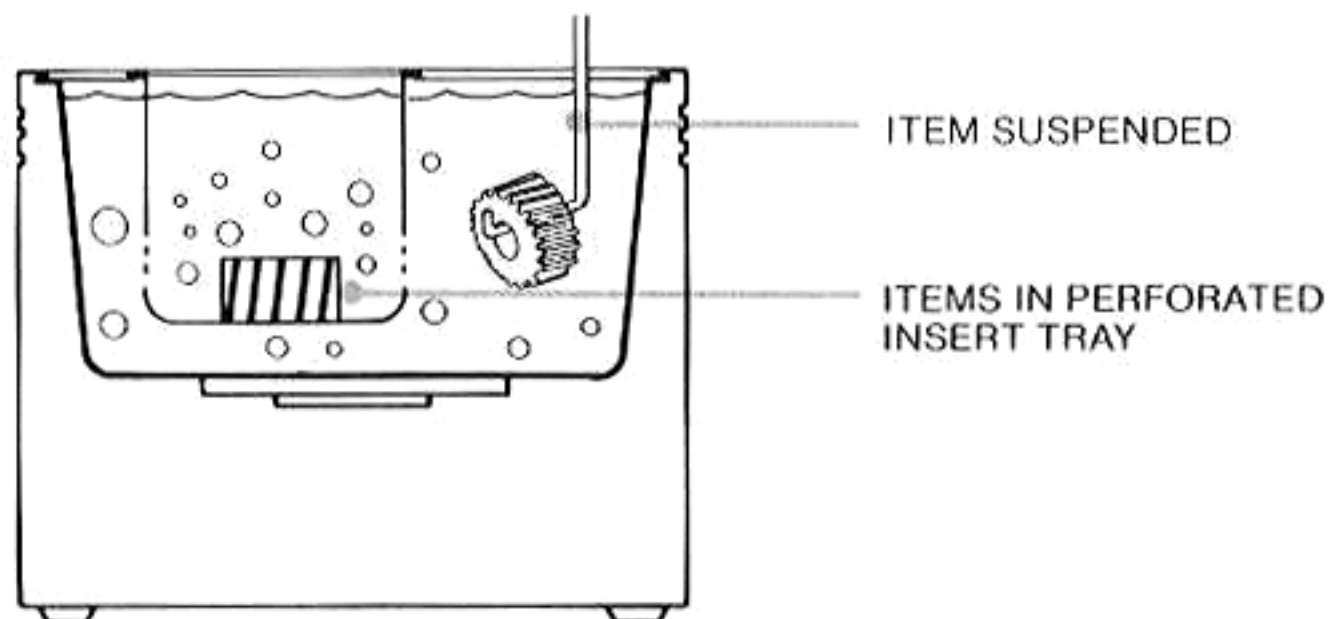

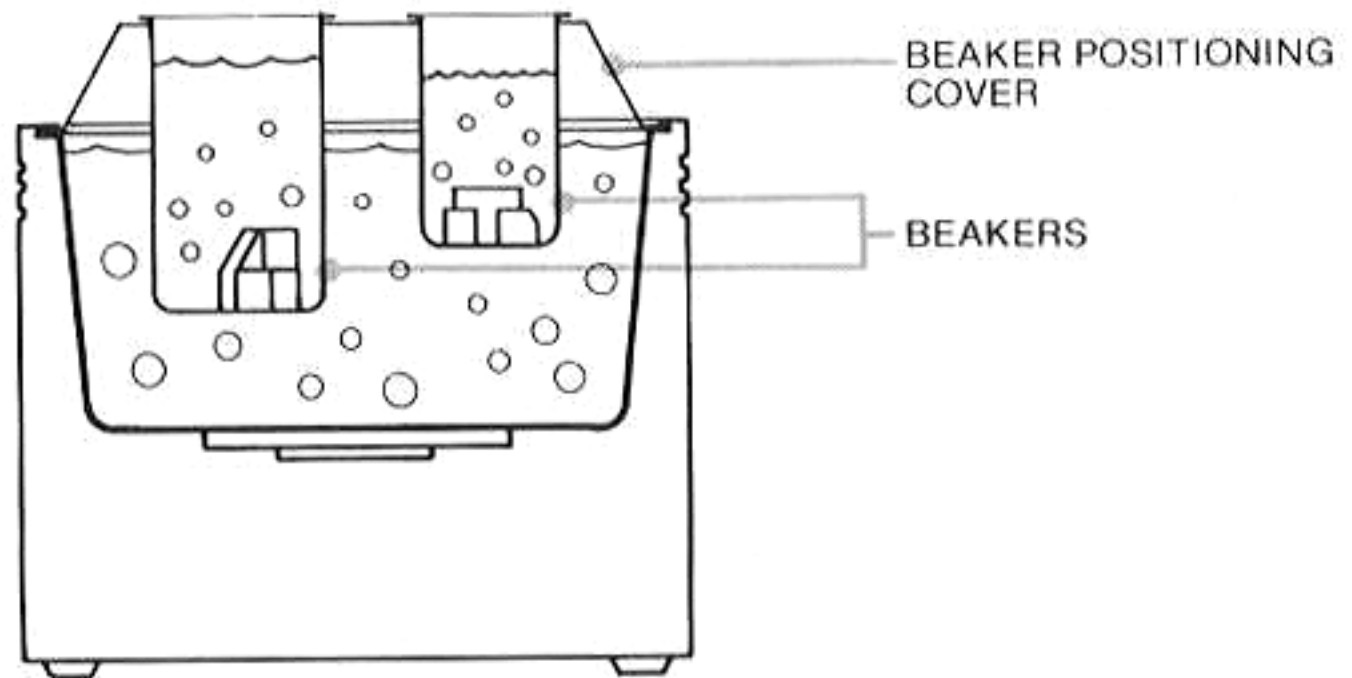

Indirect method

The indirect method provides more flexibility and control over the cleaning cycle. In this method:

- The tank is filled with a liquid driving medium, such as water plus a wetting agent (detergent), to improve cavitation.
- Cleaning solutions are poured into one or more beakers or into solid insert trays.
- The beakers are placed in a beaker positioning cover which suspends them in the tank. If a solid tray is being used, its handles should fit over the edges of the unit and suspend it in the tank.

The advantages of the indirect method are:

- Removed soil stays in the beaker or tray; it can be easily examined, filtered or discarded.
- One or more solutions may be used at the same time. For example:
 One beaker or tray with cleaning solution and one with a rinse solution.
 Two completely different cleaning solutions.

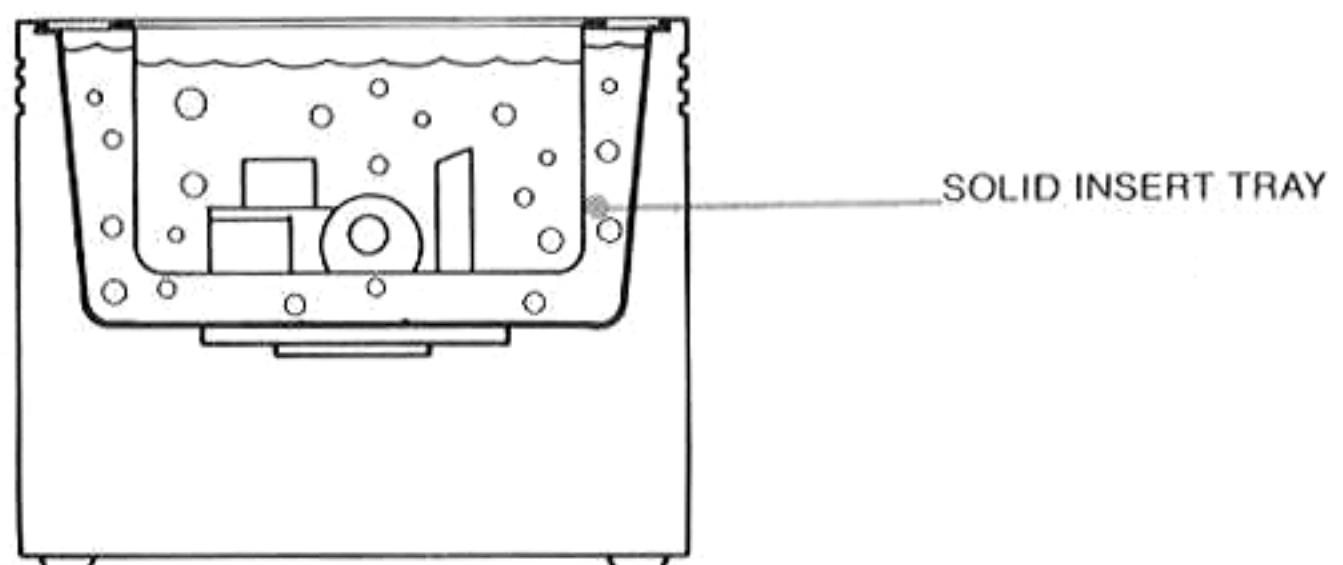

Achieving the best results

Rinsing drying and lubrication

Rinse away chemicals which adhere to items after cleaning. A highly effective method of rinsing is using a clean water bath in your Branson Ultrasonic Cleaner.

Air drying at room temperature works well for some items. Place items requiring faster drying under hot air blowers or in ovens.

Relubricate parts that need lubrication immediately after cleaning.

Cleaning solutions

The Branson Ultrasonic Cleaner was designed to operate only with NON-FLAMMABLE LIQUIDS AND WATER-BASED SOLUTIONS. DO NOT USE SOLVENTS.

Branson cleaning concentrates are formulated specifically for use in your Branson Ultrasonic Cleaner. They are listed with their recommended applications and container sizes, and are available from most Branson distributors. (See pages 18-19.)

Change the cleaning solution periodically. Like most chemicals, solutions become spent over time. Cleaning solutions can become contaminated with suspended soil particles which coat the tank bottom. This coating dampens the ultrasonic action and reduces cleaning efficiency.

Corrosive solutions

NEVER USE CORROSIVE SOLUTIONS SUCH AS STRONG ACIDS OR POWERFUL CAUSTICS DIRECTLY IN THE TANK. Besides causing damage to the unit, their use will void the warranty.

Liquid Level

When heavy or bulky loads are removed from the cleaner the liquid level may drop below the 1" level. Caution must be taken when operating heated units (-2,-4) as low liquid levels may cause the heater to fail.

Tank overload

Excessive weight on the tank bottom dampens sound energy and may cause damage to the transducer. Do not rest items on the tank bottom. Reduce the load size, and use a perforated tray to support heavy items.

BRANSON ULTRASONIC CLEANING SOLUTIONS

Water-based solutions

Your Branson Ultrasonic Cleaner was designed to *OPERATE ONLY WITH NON-FLAMMABLE LIQUIDS AND WATER-BASED SOLUTIONS*. Water-based solutions fall into two categories—acidic and alkaline. They include detergents, soaps and industrial cleaners to remove specific soils. (See *page 18*). **DO NOT USE SOLVENTS IN BRANSONIC ULTRASONIC CLEANERS.**

Alkaline water-based solutions

Alkaline water-based detergents include carbonates, silicates, caustics and phosphates. These materials help emulsifying action, keep soil from redepositing on the cleaned surface, and improve cleaning action in hard water.

Light oils and greases, cutting oils and coolant compounds can be removed with mild alkalines.

Wax or fat base buffing and polishing compounds, heavy grease and oil, waxes, vegetable oils, inks, milk residues and carbohydrates require mild to strong alkalines.

Mill scale, heat-treat scale, corrosion or oxides require heavy-duty alkalines.

Acidic water-based solutions

Acids are generally used to remove rust, tarnish or scale. They range from mild solutions that remove silver tarnish to concentrated, inhibited acidic solutions that remove investment plaster, milkstone, zinc oxide and rust from steel and cast iron as well as smut and heat-treat scale from hardened steel.

**Solutions:
amounts and
effects**

Solution amounts may vary. The amount used depends on the detergent and the type of soil to be removed. Follow the instructions on the solution container. (*See table below for effects of solutions on metals.*)

**BRANSON
ULTRASONIC
CLEANING
SOLUTIONS**

EFFECTS OF SOLUTIONS ON METALS

	<i>Steel</i>	<i>Brass</i>	<i>Aluminum</i>	<i>Magnesium</i>	<i>Zinc</i>	<i>S.S. Steel Tin Copper</i>
General purpose	none	none	slight etch*	none	none	none
Industrial strength	none	none	slight etch*	none	none	none
Oxide remover	slight etch	none	slight attack	attacks	attacks	none
Jewelry cleaner	none	none	none	none	none	none
Buffing compound remover	none	slight stain	none	none	attacks	none

*Slight etch on some aluminum alloys

BRANSONIC ULTRASONIC CLEANERS

Models 1200, 2200, 3200, 5200 and 8200 have different liquid capacities and each is available with four different options:

Model -1 Ultrasonic Cleaner

Model -2 Ultrasonic Cleaner with heater

Model -3 Ultrasonic Cleaner with timer

Model -4 Ultrasonic Cleaner with digital timer and digital heat control

See pages 12-13 for cleaner capacities and configurations.

Setup for operation is the same for all models - but the operating procedure varies, depending on the options available on the model you have purchased.

ULTRASONIC CLEANER (Model -1)

Select the cleaning method - DIRECT or INDIRECT.
(See pages 8-9.)

Select the cleaning solution. (See pages 18-19.)

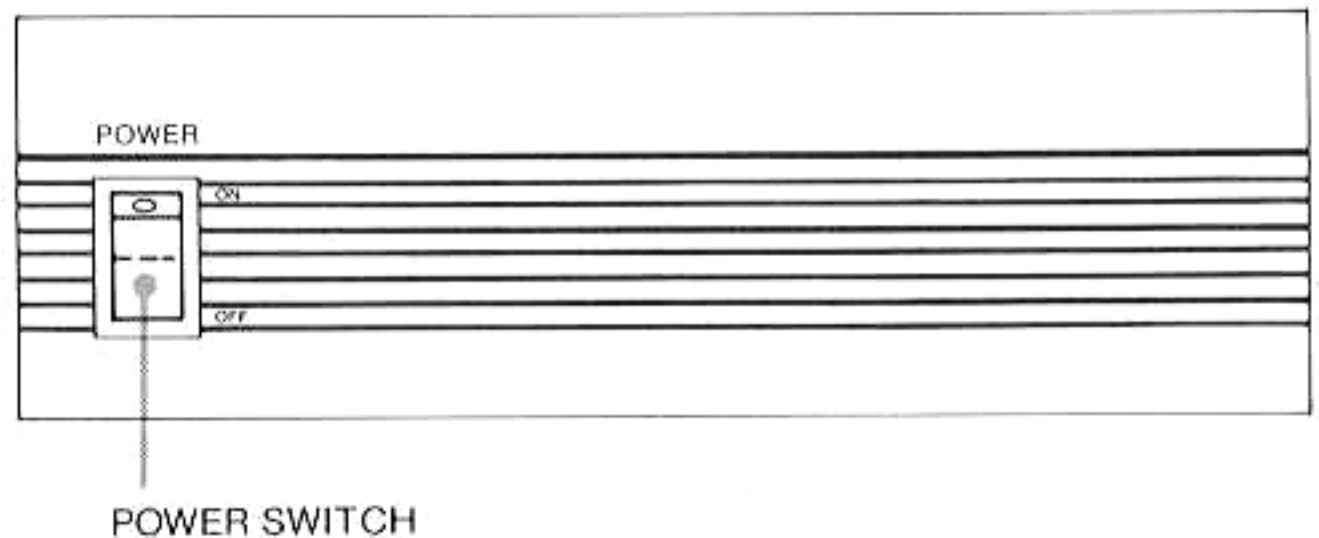

If you are using the DIRECT METHOD:

1. Fill the tank with warm tap water.

Note: The liquid should come to within one inch from the top of the tank when the tray and items to be cleaned are submerged. See. Pg. 10 for warning.

2. Add the cleaning solution to the tap water.
3. Plug the unit into its power source and press POWER to ON. Let the unit run for five to ten minutes to allow the liquid to "degas".

Operation

4. Place the items to be cleaned into a perforated tray and slowly lower the tray into the tank.
5. When the items are clean, remove the tray from the tank.
6. Rinse the clean items with clean water (the unit can be used for the rinsing cycle) and dry them, if necessary.
7. When you have finished using the unit, remember to turn it OFF.

If you are using the INDIRECT METHOD:

1. Fill the tank with warm tap water and add a wetting agent.
Note: The liquid should come to within one inch from the top of the tank when the trays or beakers (in their positioning cover) are submerged.
2. Plug the unit into its power source and press POWER to ON. Let the unit run for five to ten minutes to allow the liquid to "degas".
3. Place the items to be cleaned into individual beakers or solid trays. Pour enough cleaning solution into the beakers or trays to cover the items being cleaned.
4. Place the beakers in the positioning cover and slowly lower them into the tank.

If a solid tray is being used, its handles should fit over the edges of the unit and suspend the tray in the tank.

5. When the items are clean, remove the tray from the tank.
6. Rinse the clean items with clean water (the unit can be used for the rinsing cycle) and dry them, if necessary.

TURN OFF THE POWER AT THE END OF EACH DAY.

Operation

ULTRASONIC CLEANER WITH HEATER (Model -2)

The HEAT mode is designed to preheat and maintain the tank solution at a maximum of 50°C to 60°C (125°F to 140°F). The heater increases the chemical activity of the solution. The microscopic bubbles created by the ultrasonic action are greatly accelerated and intensified, resulting in thorough and faster cleaning.

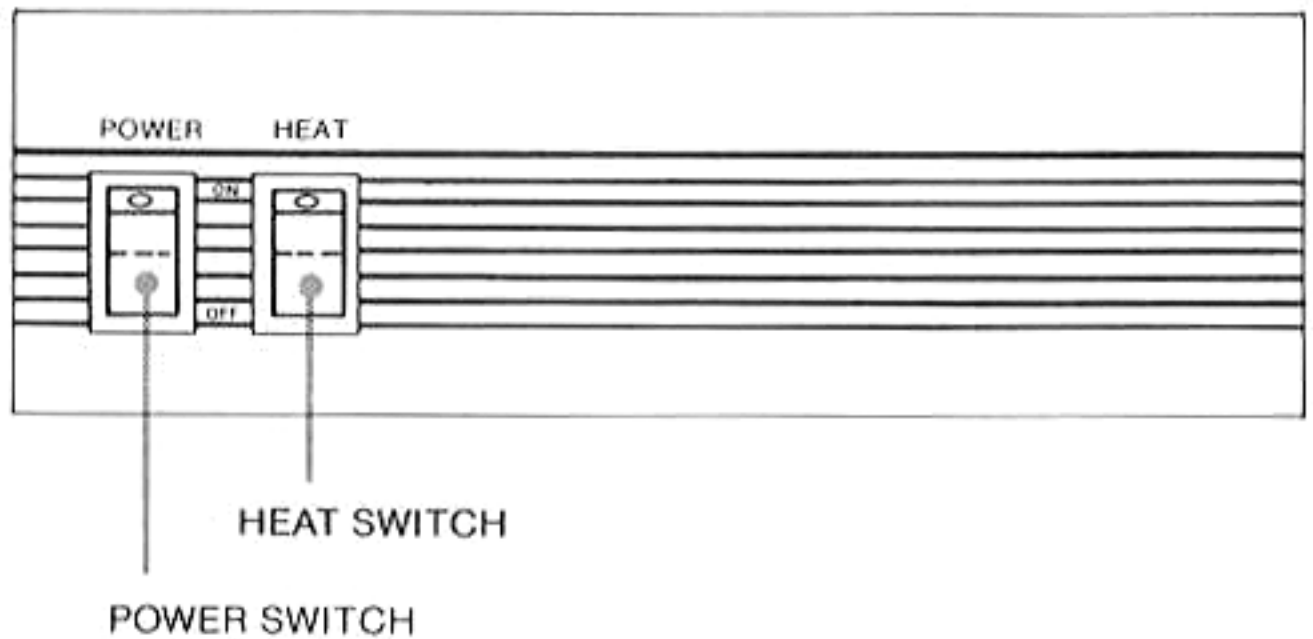

Select the cleaning method - DIRECT or INDIRECT:

1. Fill the tank with warm tap water.
Note: The liquid should come to within one inch from the top of the tank when the beakers/trays and items to be cleaned are submerged. See Pg. 10 for warning.
2. Add the cleaning solution to the tap water. (If you are using the INDIRECT METHOD, add the cleaning solution to the beakers or trays.) **USE ONLY WATER-BASED SOLUTIONS IN CLEANER.**
3. Plug the unit into its power source and press POWER and HEAT switches to ON. Let the unit run for five to ten minutes. This allows the liquid to "degas".
4. Follow ULTRASONIC CLEANER (Model-1) steps 4 through 7. In a busy office, shop or laboratory, HEAT can remain on all day.

TURN OFF THE POWER AT THE END OF EACH DAY.

ULTRASONIC CLEANER WITH TIMER (Model -3)

The digital TIMER (1 to 99 minutes) provides precise control over the short cycles typical of ultrasonic cleaning and is especially valuable when consistent results are required for consecutive batches of parts to be cleaned.

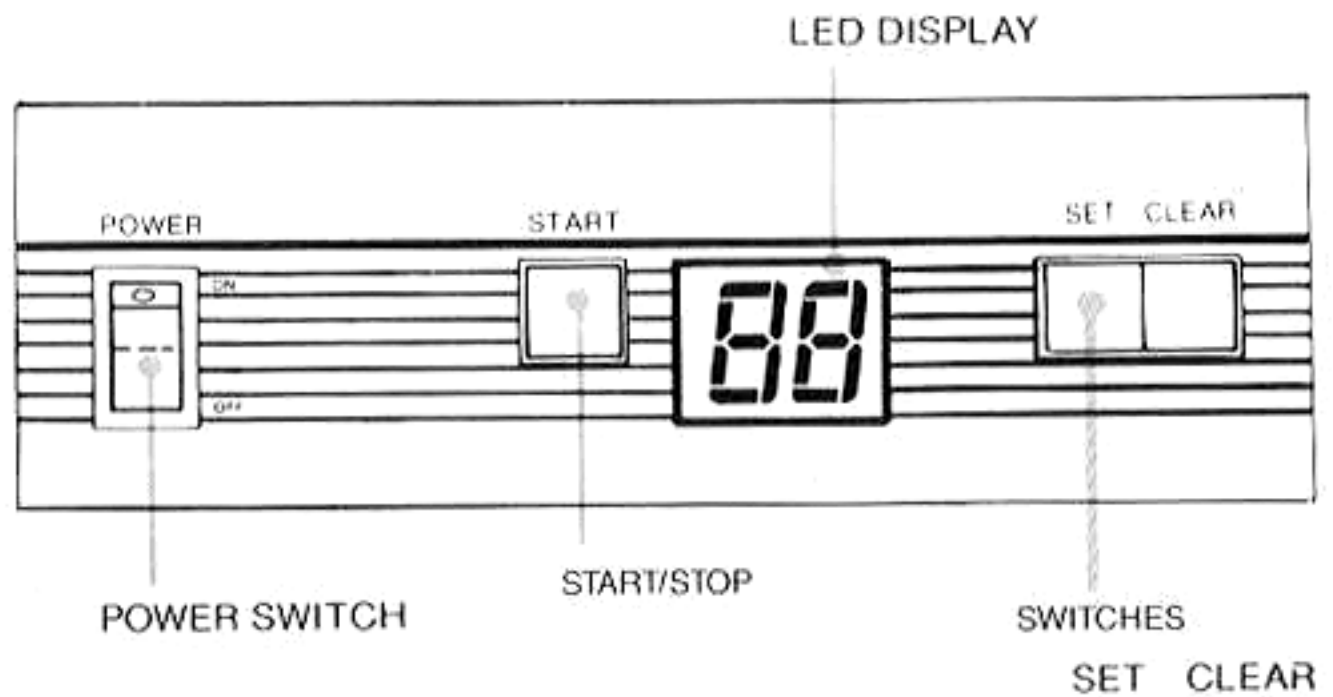

Select the cleaning method - DIRECT or INDIRECT:

1. Fill the tank with warm tap water.

Note: The liquid should come to within one inch from the top of the tank when the beakers/trays and items to be cleaned are submerged. See Pg. 10 for warning.

2. Add the cleaning solution to the tap water. (If you are using the INDIRECT method, add the cleaning solution to the tap water in the beakers or trays.)
3. Turn power ON (SET TIME LED will light). Display reads 00.

- Press START/STOP to activate the ultrasonics. The ultrasonics will run continuously when the display reads 00.

Note: Allow the unit to run for 5-10 minutes to degas.

- To stop the ultrasonics press START/STOP.

4. For timed operation press the SET switch until the desired time (00-99 minutes) is displayed.

- Press START/STOP to start timer and turn ultrasonics on.

- To interrupt cleaning cycle, press START/STOP.

- To resume cleaning cycle, press START/STOP.

Note: A timed cleaning cycle interrupted by pressing START/STOP will resume its countdown at the interrupted point when START/STOP is pressed again.

Operation

5. To repeat the timed cleaning cycle after the cycle has finished, press START/STOP.

To reset TIME while the cleaning cycle is running:

- Press START/STOP to interrupt the cycle.
- Press CLEAR, 00 minutes will appear on the time LED display.
- Press SET until the minutes required for the cleaning cycle appear on the time LED display.
- Press START/STOP to resume the cleaning cycle.

6. Select operation mode.

- For TIMER MODE: Press SET until the minutes (from 1 to 99 minutes) required for the cleaning cycle appear on the time LED display. Release SET.
- For CONTINUOUS MODE: Press CLEAR to set time LED display at 00 minutes. When set at 00 minutes, the unit is ready to operate in the CONTINUOUS MODE.

7. Follow ULTRASONIC CLEANER (Model-1) steps 4 through 6. When unit is in TIMER MODE, consecutive batches may be cleaned without reprogramming, because the cleaning cycle time remains in memory until it is reset or the POWER switch is turned OFF.

To repeat the timed cleaning cycle after the cycle has finished, press START/STOP.

To reset TIME while the cleaning cycle is running:

1. Press START/STOP to interrupt the cycle.
2. Press CLEAR. 00 minutes will appear on the time LED display.
3. Press SET until the minutes required for the cleaning cycle appear on the time LED display.
4. Press START/STOP to resume the cleaning cycle.

Note: A timed cleaning cycle interrupted by pressing START/STOP will resume its countdown at the interrupted point when START/STOP is pressed again.

TURN OFF THE POWER AT THE END OF EACH DAY.

ULTRASONIC CLEANER WITH DIGITAL TIMER AND DIGITAL HEAT CONTROL

(Model -4)

The digital timer and heat control mode combination provides precise control when consistent time and temperature are required for good results. The temperature can be monitored on the LED display. The temperature can also be controlled by the microprocessor according to the temperature (0-65°C) entered in "Set Temp" mode.

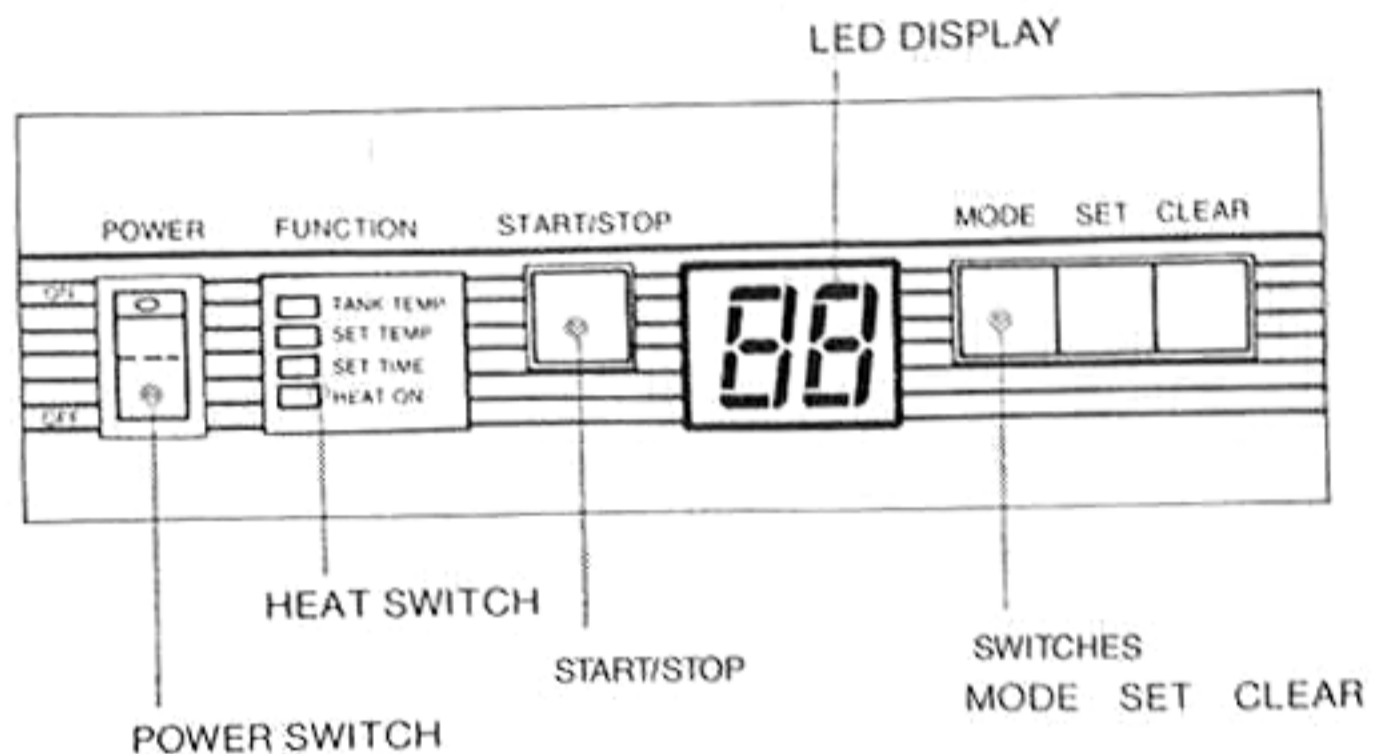

LED Function Explanation

"Tank Temp"

Displays tank temperature in °C from 0-99°C. ($\pm 10^\circ\text{C}$) (Monitor Temp Mode).

"Set Temp"

Allows the required tank temperature to be set from 0 to 65°C. If Start/Stop is pressed in this mode, the "Heat On" LED will either go on or off. (Control Heat Mode).

"Set Time"

Allows the timer to be set from 0-99 minutes. Press start/stop to turn ultrasonics on/off. If the display is 00 and START/STOP is pressed, the ultrasonics goes on in the continuous mode. If the display has a value of 01-99 pressing start/stop will start or stop the ultrasonics with the timer running. It will automatically stop at the end of the programmed time. (Timer Mode).

"Heat On"

This LED, when lit, indicates the microprocessor is controlling the tank temperature to the set point set in the "Set Temp" mode. When tank temperature reaches the setpoint, the heaters shut off. When the tank temperature decreases to 5°C below the setpoint, the heater will be reactivated.

Operation

IMPORTANT: MODEL-4 USES A SLIGHTLY DIFFERENT OPERATING PROCEDURE THEN -1, -2 AND -3 MODELS. FAILURE TO READ AND UNDERSTAND THE FOLLOWING MAY CAUSE YOU TO BELIEVE YOUR UNIT IS DEFECTIVE.

IN THE EVENT THE TANK TEMPERATURE RISES TO APPROXIMATELY 75°C ($\pm 5^\circ\text{C}$) A THERMAL PROTECTION WILL AUTOMATICALLY SHUT OFF THE HEAT AND ULTRASONICS. DISPLAY WILL READ "OF". IF THIS HAPPENS TURN OFF THE POWER SWITCH AND ALLOW THE UNIT TO COOL DOWN. TO RESUME NORMAL OPERATIONS TURN THE POWER SWITCH BACK ON AND FOLLOW THE STEPS LISTED BELOW.

Start-Up:

1. Follow ULTRASONIC CLEANER WITH TIMER (Model-3) steps 1 and 2.
2. Turn power ON (SET TIME LED will light). Display reads 00.
 - Press START/STOP to activate the ultrasonics. The ultrasonics will run continuously when the display reads 00.

NOTE: Allow the unit to run for 5-10 minutes to degas.

- To stop the ultrasonics press START/STOP.
3. For timed operation press the SET switch until the desired time (00-99 minutes) is displayed.
 - Press START/STOP to start timer and turn ultrasonics on.
 - To interrupt cleaning cycle, press START/STOP.
 - To resume cleaning cycle, press START/STOP.

NOTE: A timed cleaning cycle interrupted by pressing START/STOP will resume its countdown at the interrupted point when START/STOP is pressed again.

NOTE: When the unit is in TIMER MODE, consecutive batches may be cleaned without reprogramming, because the cleaning cycle time remains in memory until it is reset or the POWER switch is turned OFF.

To repeat the timed cleaning cycle after the cycle has finished, press START/STOP.

To reset TIME while the cleaning cycle is running:

- Press START/STOP to interrupt the cycle.
- Press CLEAR, 00 minutes will appear on the time LED display.
- Press SET until the minutes required for the cleaning cycle appear on the time LED display.
- Press START/STOP to resume the cleaning cycle.

5. To set the temperature press the MODE switch twice (SET TEMP LED will light).

- Press SET switch until desired temperature (00-65 C) is displayed.
- Press START/STOP to activate heater.
- To shut off heater press START/STOP switch.

NOTE: LED function light must be in the SET TEMP mode.

6. To check the temperature of the liquid solution in the tank:*

- Press MODE until the green TANK TEMP LED is lit. The numbers displayed are the tank temperature in degrees Centigrade ($\pm 10^{\circ}\text{C}$).

Note: The cleaning cycle continues to count down during the time the temperature is being displayed.

If a more accurate temperature reading is required, the ultrasonics have to be turned off. To do this:

- Press MODE twice (SET TIME LED will light).
- Press START/STOP to interrupt the cleaning cycle.
- Press MODE once to return to the monitor mode (TANK TEMP LED will light).
- Use a laboratory thermometer to determine the tank temperature.
- If the temperature readings on the thermometer and the LED display are identical, the unit is calibrated.
- If the temperature readings on the thermometer and LED display do not agree:
 - Press CLEAR.
 - Press and hold SET until the temperature reading on the LED display is identical to that on the thermometer.

The unit is now calibrated, and will remain accurate until the power switch is turned off.

Note: During a continuous cleaning process using ultrasonics and heat, the tank temperature may rise above the set temperature. This will cause the heater to shut off and remain off. This is caused by the added heat generated by the addition of the ultrasonics. If the ultrasonics are switched off, the tank will cool, allowing the heater control to function as normal.

**Note: The ultrasonics may affect the accuracy of the monitored temperature. For the most accurate reading wait 20 - 80 seconds after shutting off the ultrasonics before taking the reading.*

TURN OFF THE POWER AND HEAT AT THE END OF EACH WORK DAY.